



800 SERIES "NU-TWIST"® ADAPTERS

Phone: 866-634-8884

Fax: 866-239-6995

Email: cmw@cmwinc.com

800 SERIES "NU-TWIST"® ADAPTERS

CMW "NU-TWIST"® FEATURES

1. Hex locking nut may be tightened or loosened effectively by hand or wrench for easy replacement of electrodes.
2. "O" ring seals provide water tight connections.
3. Double groove construction in bore or locking nut accurately aligns and locks the

electrode in position with a maximum of a turn and one half.

4. Through use of baffles in adapters and in electrodes over 1" long efficient cooling is effectively achieved.
5. All components are of corrosion-resistant alloys.
6. Maintenance costs are unusually low.
7. Adapter bases are CMW®3 material.

SURFACE MOUNTED ADAPTERS

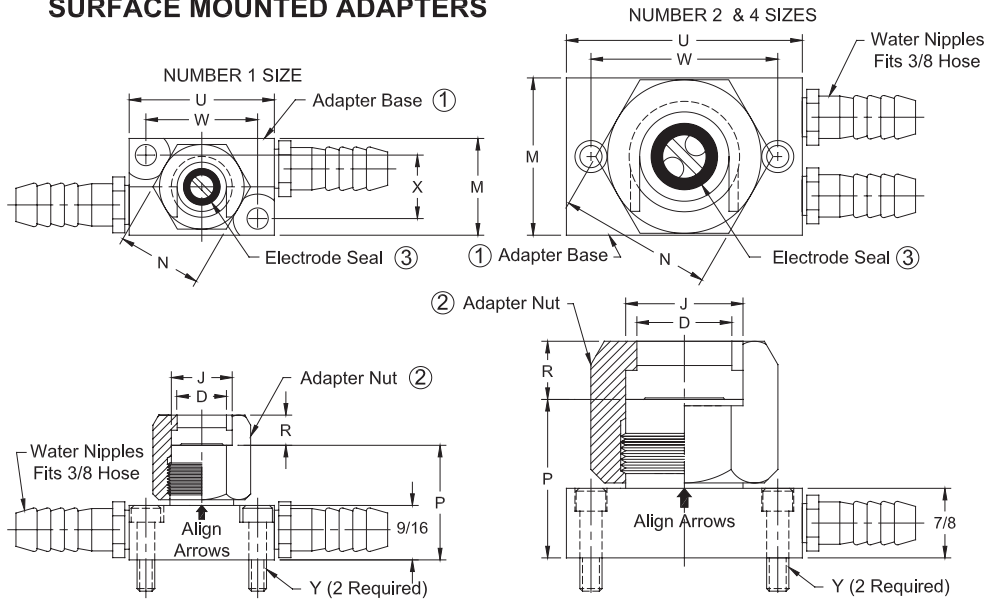
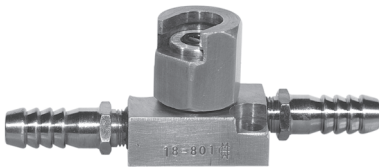
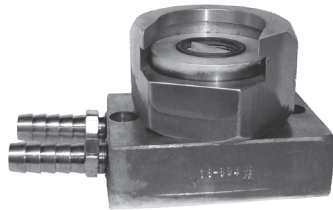

800 SERIES "NU-TWIST"® SURFACE MOUNTED											
Size	Adapter Part No.	Adapter Size									
		D	J	M	N	P	R	U	W	X	Y
1	18-801	1/2	5/8	1	7/8	1-1/4	1/4	1-1/2	1-5/32	21/32	No. 10-24 Scr.
2	18-802	15/16	1-1/8	1-1/2	1-1/2	1-13/16	7/16	2-1/2	2	--	No. 1/4-20 Scr.
4	18-804	1-7/16	1-5/8	2	2	1-13/16	7/16	3	2-3/8	--	No. 1/4-20 Scr.

REPLACEMENT PARTS				
Adapter Part No.	Water Nipples	Adapter Base 1	Adapter Nut 2	Electrode Seals 3
18-801		18-80110	18-80150	18-10060-5
18-802	18-10050	18-80210	18-80250	18-10060-1
18-804		18-80410	18-80450	18-10061-14

For replacement parts see page 49

800 SERIES "NU-TWIST"® THREADED ADAPTERS & MOUNTING INFORMATION

May use with 100, 200, and 300 series holders to make "NU-TWIST"® holders

NUMBER 1 SIZE

NUMBER 2 & 4 SIZES

800 SERIES "NU-TWIST"® THREADED									
Size	Adapter Part No.	Adapter Size							
		D	J	M	N	P	R	S	T (Thread)
1	18-811	1/2	5/8	1	7/8	15/16	1/4	9/16	5/8-18
2	18-812	15/16	1-1/8	1-1/2	1-1/2	1-5/16	7/16	3/4	1-14
4	18-814	1-7/16	1-5/8	2	2	1-5/16	7/16	3/4	1-1/2-12

For replacement parts see page 49

NUMBER 1 SIZE

NUMBER 2 & 4 SIZES

MOUNTING INFORMATION FOR THREADED ADAPTERS							
Size	Thd. Adapter Assy. No.	C'bore Dia. A	C'bore Depth B	Thread Depth Min. C	Tube Height E	Tube Dia. F	Thread T
1	18-811	.750	.083	5/8	3/8	.244	5/8-18
2	18-812	1.126	.113	13/16	15/16	.244	1-14
4	18-814	1.626	.173	13/16	15/16	.375	1-1/2-12

800 SERIES "NU-TWIST"[®] THREADED ADAPTER REPLACEMENT PARTS



Phone: 866-634-8884

Fax: 866-239-6995

Email: cmw@cmwinc.com

800 SERIES "NU-TWIST"[®] THREADED ADAPTERS

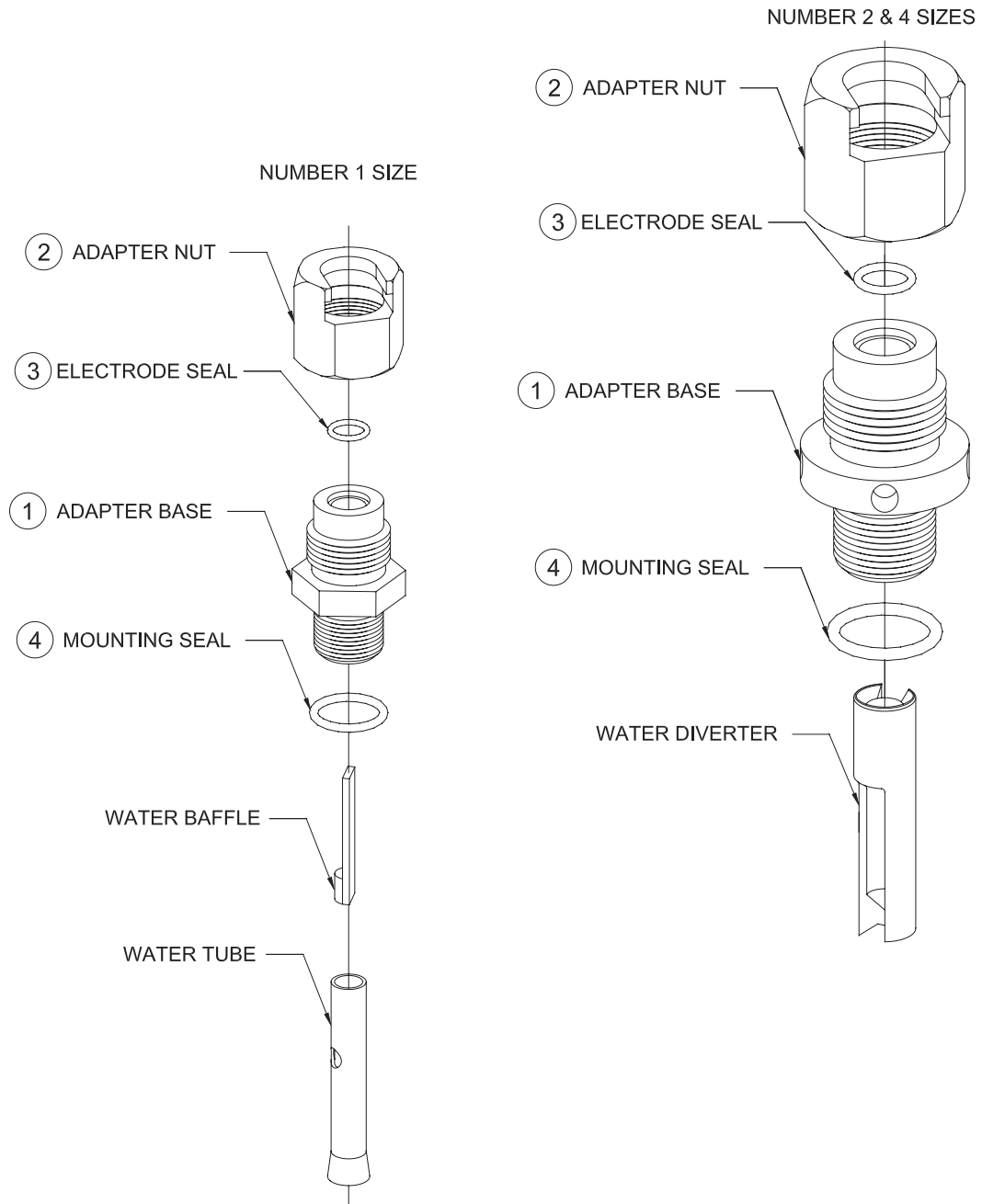

Adapter Assembly Part No.	Adapter Base* 1	Adapter Nut 2	Electrode Seal 3	Mounting Seal 4
18-811	18-81110	18-80150	18-10061-5	18-10060-11
18-812	18-81210	18-80250	18-10061-10	18-10060-17
18-814	18-81410	18-80450	18-10061-14	18-10060-25

* Adapter base includes water tube & baffel or water diverter