



DOUBLE BEND ELECTRODES

Phone: 866-634-8884

Fax: 866-239-6995

Email: cmw@cmwinc.com

Offset D	Taper Size	Nose End N	Taper End T	Dome, Pointed & Flat, O.A.L. C	Pointed Nose Part No.
1/2	4 RW	3/4	7/8	2	321-0832-23
		3/4	7/8	2-1/2	321-0840-23
	2	7/8	3-1/4	321-0852-93	
	5 RW	1	1	2-1/2	322-0840-44
1		1	2-3/4	322-0844-44	
1		1	3-1/4	322-0852-44	
2		1	3-1/2	322-0856-94	
3/4	4 RW	3/4	7/8	2	321-1232-23
		3/4	7/8	2-1/2	321-1240-23
	2	7/8	3-1/2	321-1256-93	
	5 RW	1	1	2-3/4	322-1244-44
1		1	3	322-1248-44	
2		1	3-1/2	322-1256-94	
1	4 RW	3/4	7/8	2-1/4	321-1636-23
		3/4	7/8	2-3/4	321-1644-23
		1-3/4	7/8	3-1/4	321-1652-83
		3/4	7/8	3-1/2	321-1656-23
	5 RW	1	1	2-3/4	322-1644-44
		1	1	3	322-1648-44
		1	1	3-1/2	322-1656-44
		1-3/4	1	3-1/2	322-1656-84
1-1/4	4 RW	3/4	7/8	2-1/2	321-2040-23
		3/4	7/8	3	321-2048-23
		1-1/2	7/8	3	321-2048-73
	5 RW	1	1	2-3/4	322-2044-44
		1	1	3-1/4	322-2052-44
		1	1	3-1/2	322-2056-44
1-1/2	5 RW	1-1/2	1	3-1/2	322-2056-74
		1-3/4	1	3-1/2	322-2056-84
		1	1	2-3/4	322-2444-44
		1-1/4	1	3	322-2448-64
1-3/4	5 RW	1	1	2-3/4	322-2844-44
1-1/4		1	3	322-2848-64	

DOUBLE BEND ELECTRODES

CMW double bend electrodes are cold formed from full hard straight electrodes, and have properties superior to those obtainable by casting or hot forging methods. Cooling tubes, unless otherwise specified are bent in place to provide coolant flow near the welding face as in the case of straight electrodes. These extra values assure you of longer electrode life, longer runs between dressings, and highest weld quality. CMW®3 material is standard for these electrodes. CMW®28, CMW®100, available on special order.

DOUBLE BEND POINTED NOSE

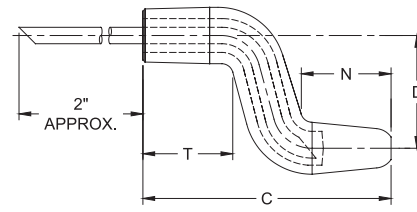

Bent dimensions are for reference only

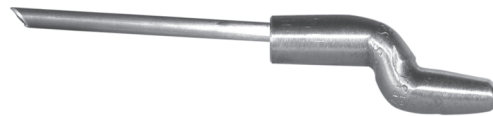

Water Tube Sizes:
4RW = .182 O.D.
5RW = .245 O.D.

DOUBLE BEND ELECTRODE CODING SYSTEM

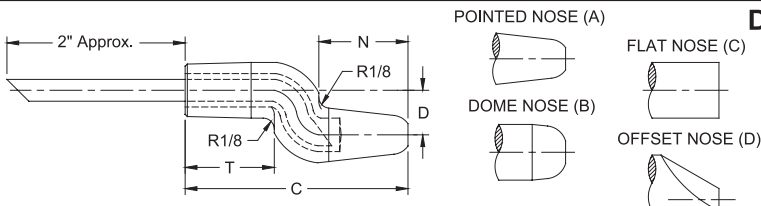

EXAMPLE:

322-0840-44

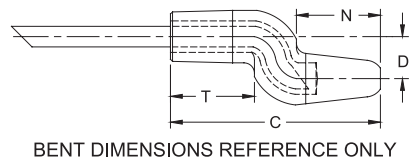
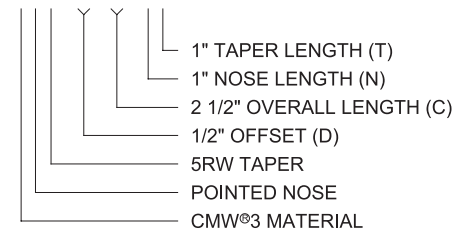

BENT DIMENSIONS REFERENCE ONLY

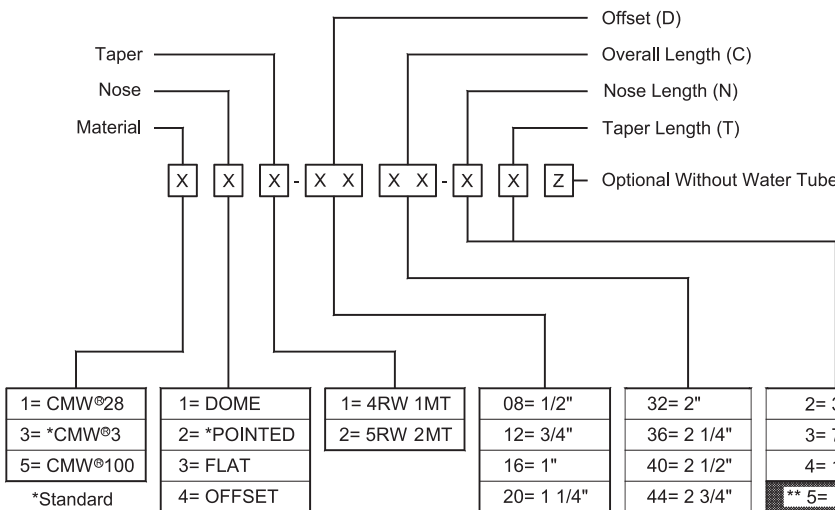

1= CMW®28
3= *CMW®3
5= CMW®100
*Standard

1= DOME
2= *POINTED
3= FLAT
4= OFFSET

1= 4RW 1MT
2= 5RW 2MT

08= 1/2"
12= 3/4"
16= 1"
20= 1 1/4"
24= 1 1/2"
28= 1 3/4"

32= 2"
36= 2 1/4"
40= 2 1/2"
44= 2 3/4"
48= 3"
52= 3 1/4"
56= 3 1/2"
60= 3 3/4"

2= 3/4"
3= 7/8"
4= 1"
** 5= 1 1/8"
** 6= 1 1/4"
** 7= 1 1/2"
** 8= 1 3/4"
** 9= 2"

**May not be a stock item
Standard 4RW nose length = 3/4"
Standard 4RW taper length = 7/8"
Standard 5RW nose & taper length = 1"

- See Page 6 for Metric Conversion
- See Page 7 for Taper Dimensions

Water Tube Sizes:
4RW = .182 O.D.
5RW = .245 O.D.