





Why Partner with CMW?
Experience • Technology • Results

Your One Source for Resistance Welding Products

Worldwide Distribution

Thousands of Items in Stock

Ask About Volume Buying Programs

Order via Phone, Fax, EDI, or E-Commerce

Same Day Shipping for Stock Parts

Order by 2:00 P.M. EST

ISO 9001:2015 Certified

Largest Selection of Resistance Welding Products

We Can Answer Your Resistance Welding Questions

Ask the Welding Experts!

CALL US TOLL FREE
800-521-3722

or visit us at
www.cmwinc.com
for a distributor near you



RESISTANCE WELDING PRODUCTS

- ELECTRODES • HOLDERS • BAR STOCK • SEAM WELDING WHEELS • RINGS
- SPECIAL TOOLING • SHAFTS • BUSHINGS • CASTINGS
- FORGINGS • ELECTRODE MATERIALS

**Special electrodes, holders and tooling for
resistance welding applications**

Continuously serving the resistance Welding Industry since 1929, CMW has been an industry leader in the development, engineering and manufacturing of a variety of products. In addition, CMW offers a diversity of special metals for resistance welding applications. CMW's resistance welding products are engineered to provide the most effective materials commercially available to help achieve top quality welds. Experienced CMW Product engineers will aid you in the design and production of standard or special parts for your application to insure maximum efficiency from CMW's resistance welding products.

Phone: 800-521-3722
Fax: 864-877-2212
Email: cmw@cmwinc.com
Website: www.cmwinc.com



RESISTANCE WELDING PRODUCTS

Phone: 800-521-3722





Fax: 864-877-2212

Email: cmw@cmwinc.com

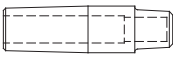

APPLICATION AND DATA SHEETS

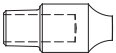
CMW Copper Base Alloys	4
Refractory Metal Compositions	5
Metric Conversions Inches to Millimeters	6
Taper Dimensions	7
CMW and RWMA Straight Electrode Coding	7
Holder and Electrode Application Sketches	38
Multispot Pressure Equalizing Holder Setups	60
WA2 Weld Analyzer	64
Spot Welding Schedules for Low Carbon Steel	68
Projection Welding Schedules for Low Carbon Steel	69
Welding Schedules for Stainless Steel	70
Welding Schedules for Galvanized Low Carbon Steel	71
GCAP® Weld and Stepper Schedule	72
Recommended Electrode Materials	73
Resistance Welding Electrode Maintenance	74
Do's and Don'ts for Resistance Welding Electrodes	75
Welding Electrode Evaluation Form	76
Quote Request	77

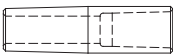
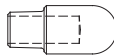
CAP ELECTRODES GCAPS®AND SHANKS

 	Cap Electrodes	8, 9, 10, 11
 	GCAP® Electrodes	9
 	Cap Shanks	12, 13

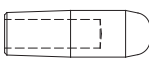
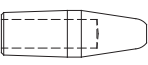
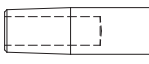
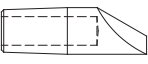
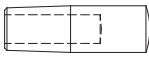
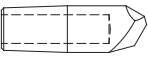
STRAIGHT ELECTRODES

 	Dome and Pointed Nose	14
 	Flat and Offset Nose	15
 	Radius, Truncated, and 30° Nose	16
	Refractory Metal Faced Nose	16

BENT ELECTRODES

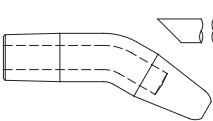
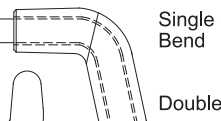
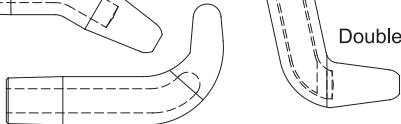
 	Single and Radius Bend	17
	Double Bend	18



THREADED ELECTRODES

 	30
---	-----------	----

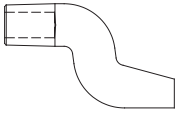
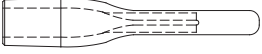
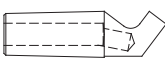
IRREGULAR ELECTRODES

	Crank	19, 20
	Spade	21
	Gun	22

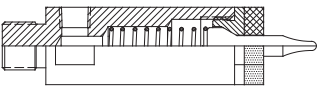
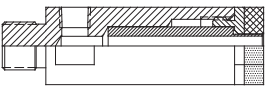
STUD AND NUT ELECTRODES

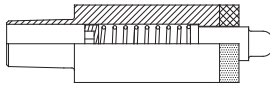
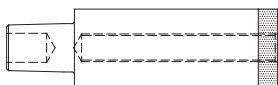
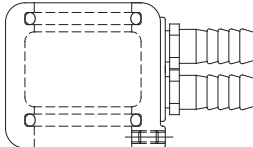
	Chameleon/Max-Life™ Nut Electrodes	23
	Chameleon/Max-Life™ Stud Electrodes	24
	Self-Piloting Nut Electrodes	25
	Non-Piloting Nut Electrodes	26
	Stud Electrodes	28
	Cooling Jackets for Stud and Nut Electrodes	27

BACK-UP ELECTRODES

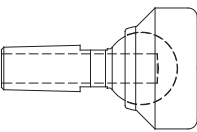
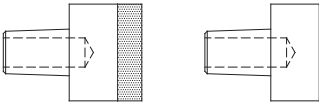
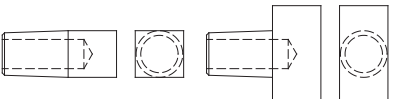
	Swivel Head	29
	Large Round Head Class 2 and 10W Faced	29
	Square and Rectangular Head	29

THREADED SOCKET (OR BUTTON) ELECTRODES

	47
---	-----------	----

"NU-TWIST"®ELECTRODES

	51
--	-----------	----





Phone: 800-521-3722



Fax: 864-877-2212

Email: cmw@cmwinc.com

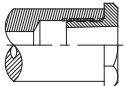
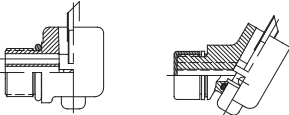
HOLDER TO ELECTRODE ADAPTERS

	Non Ejector 31
	Ejector 34
	Assembly Examples 32, 34, 36, 38, 43, 53 & 60
	Universal 46

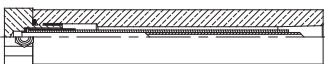
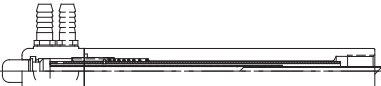
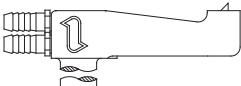
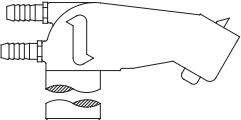
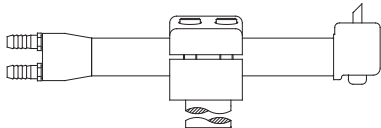
ELECTRODE HOLDERS

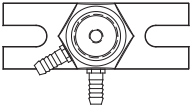
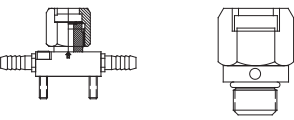
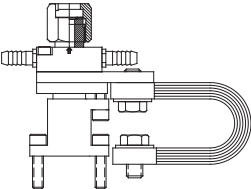
	100 Series Straight Non Ejector 32, 33
	200 Series Straight Ejector 34, 35
	300 Series Premium Straight Ejector 36, 37
	400 Series Light Non-Ejector Offset 39, 40
	500 Series Heavy Duty Ejector Offset 41, 42, 43
	600 Series Universal Holder Components 45
	Platen Mounted Holders 49
	800 Series "Nu-Twist" [®] Surface and Threaded Adapters .. 50, 51
	Hydraulic Equalizing Adapters for 800 Series 54, 55, 56, 57

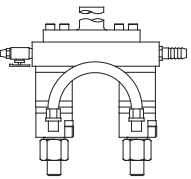
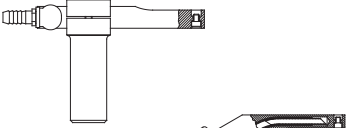
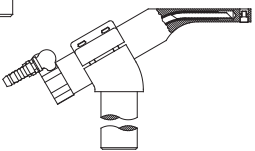
	Dual Mounted Hydraulic "Nu-Twist" [®] Assemblies 52, 53
	900 Series Light Universal Holders for Socket Electrodes 48
	950 Series Paddle Holders for Socket Electrodes 48



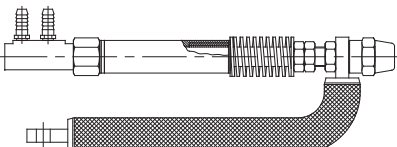
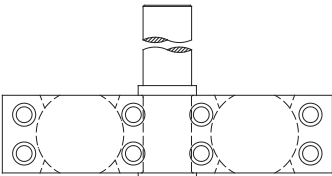



LOW INERTIA HOLDERS

	1100 Series Adjust-A-Pressure Low Inertia Holders 58, 59
	1150 Series Adjust-A-Pressure Adapters 58

MULTISPOT ADAPTERS FOR AIR OR HYDRAULIC PISTONS

	1200 Series Multi-Spot Adapters 61
---	---

ACCESSORIES

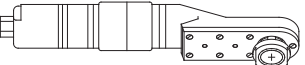
	Shunt and Cables..... 62
	Cap Electrode Extractor Fork 63
	Reamers, Hose Connectors, and Hose Clamps 63
	Hand Electrode Dresser 63
	Weld Analyzer 64
	Force Gauge 66
	Pneumatic Electrode Dresser and Cutters 65



COPPER BASE ALLOYS

Phone: 800-521-3722

Fax: 864-877-2212

Email: cmw@cmwinc.com

Long electrode life is of paramount importance to the user of resistance welding equipment. Selection of the proper CMW alloy or combination of alloys will help to give improved weld strength and electrode life.

CMW electrodes are fabricated from alloys selected from the results of laboratory and practical field tests. For special problems, CMW engineers will make recommendations based on their years of experience.

Typical Physical and Mechanical Properties of Copper Based Alloys

Copper Based Alloys	Condition	Principal Elements	R.W.M.A. Alloy Number	Hardness Rockwell	Electrical Conductivity %I.A.C.S.	Ultimate Tensile Strength, psi	Elongation % in 2"	Permanent Softening Begins at	
								°C	°F
CLASS 1 (1.15000)	Wrought**	Copper, Zirconium	1.15000	70 B	90	66,000	10	500	930
CLASS 2 (2.18200)	Cast	Copper, Chromium	2.18200	70 B	80	50,000	20	500	930
	Wrought***			83 B	85	75,000	15	500	930
CLASS 2 (2.18150)	Wrought***	Copper, Chromium, Zirconium	2.18150	83 B	85	75,000	15	500	930
CLASS 3 (3.18000)	Wrought	Copper, Nickel, Silicon, Chromium	3.18000	94 B	48	100,000	13	455	850
	Cast			90 B	48	85,000	10	455	850
CLASS 3 (3.17510)	Wrought	Copper, Nickel, Beryllium	3.17510	100 B	48	110,000	10	455	850
CLASS 4 (4.17200)	Cast	Copper, Beryllium	4.17200	38 C	20	110,000	2	375	710
	Wrought			38 C	23	170,000	4	375	710
Copper	Cast Wrought	Pure Copper	—	30 B 40 B	95 100	25,000 40,000	50 35	200 200	390 390

Note: All properties shown are TYPICAL and should not be used for specifications

** Cold drawn bars up to 5/8" diameter

*** Heat treated and cold drawn bars up to 1" diameter

TYPICAL USAGE

RWMA CLASS 1 (1.15000) Copper, Zirconium material is recommended for spot welding of coated steels and high conductivity materials, excluding copper and silver.

RWMA CLASS 2 (2.18200) Copper, Chromium material is recommended for spot and seam welding cold and hot-rolled steels and coated materials as well as current carrying shafts and arms, back-up bars for both resistance and arc welding and electrical current carrying structural parts and springs.

RWMA CLASS 2 (2.18150) Copper, Chromium, Zirconium is recommended for spot and seam welding cold and hot rolled steels. It is often used for galvanized and coated steel.

RWMA CLASS 3 (3.18000) this is a Beryllium free copper product with properties similar to beryllium coppers and able to function in most Class 3 applications.

RWMA CLASS 3 (3.17510) Copper, Beryllium material is recommended for spot and seam welding stainless steel and high temperature heat resisting alloys requiring high weld forces, flash welding dies, back-up bars, projection welding electrodes, and high strength, high conductivity electrical components and springs.

RWMA CLASS 4 (4.17200) Copper, Beryllium material is recommended for flash welding dies, springs, electrical components, high strength backing material for brazed assemblies and wire guides.



The refractory metals below are groups of metal compositions whose elements consist basically of the refractory metals tungsten, molybdenum and tungsten carbide combined with copper. Combinations of these elements produce dense, hard metals of superior wear resistance and strength at elevated temperatures, coupled with good thermal and electrical conductivity. The mechanical and physical properties of these materials make them particularly suitable as the die inserts and facings for volume projection welding, flash and butt welding, electrical upsetting, electroforging and mash welding applications.

These materials are also used successfully as facing on spot welding electrodes where heat balance or mechanical wear resistance are required. The initial premium cost of these refractory metals is offset by lower production cost per weld due to long tool life and less electrode dressing time. The high stability of these materials insures uniform heating and prevents misalignment, resulting in a higher quality weld.

Typical Physical and Mechanical Properties of Refractory Based Materials

Grade	Refractory Based Materials	Type of Material	R.W.M.A. Group B Material	Hardness Rockwell	Electrical Conductivity %I.A.C.S.	Ultimate Tensile Strength, psi	Cross Breaking Strength psi
1W	RWMA CLASS 10	Tungsten-Copper		77 B	53	63,000	110,000
10W	RWMA CLASS 11	Tungsten-Copper	ASTM B702 C1D	98 B	45	90,000	150,000
30W	RWMA CLASS 12	Tungsten-Copper	ASTM B702 C1E	103 B	41	98,000	170,000
100W	RWMA CLASS 13	Tungsten		39 C	30	150,000	200,000
100M	RWMA CLASS 14	Molybdenum	ASTM B387 Type 360	90 B	30	80,000	120,000

Note: All properties shown are TYPICAL and should not be used for specifications

* Properties are in fully heat treated condition

** Hardness is 56 HRA at 1475 °F (800°C)

TYPICAL USAGE

RWMA CLASS 10 • CMW 1W

TUNGSTEN 55% - COPPER 45% materials are generally used for flash and butt welding die inserts where higher electrical and thermal conductivity is necessary and where a degree of malleability is desirable. These materials are also used for spot welding (as a radius faced electrode) low conductivity ferrous metals such as stainless steel.

RWMA CLASS 11 • CMW 10W

TUNGSTEN 75% - COPPER 25% material is used for electrode and die inserts in most flash and butt welding dies and for projection welding dies where welding pressures are moderate. It is also used for light electrical upsetting, electroforging dies and seam welder bushing inserts.

RWMA CLASS 12 • CMW 20W

TUNGSTEN 80% - COPPER 20% material is recommended for volume projection welding dies where the pressures involved are relatively high. Electrical upsetting of non-ferrous metals and low carbon steel is usually accomplished by the use of such RWMA CLASS materials as die facings. Cross-wire welding of large, diameter wire and rod is accomplished with such RWMA CLASS materials.

RWMA CLASS 13 • CMW 100W

TUNGSTEN 100% is extremely hard and its ductility is relatively low. It cannot be machined but may be ground to the required shape. It does not alloy appreciably with nonferrous materials and is used for cross-wire welding of metals such as copper and brass. It is also used for electro brazing electrode material and for some electrical upsetting operations.

RWMA CLASS 14 • CMW 100M

MOLYBDENUM 100% is used principally for electro brazing electrode material and for cross-wire welding of nonferrous metals. It is not as hard as RWMA CLASS 13 material and may be machined or drilled to fit the parts to be joined. A typical application of this material, as an electrode, is the welding or brazing of braided or solid copper conductors to ferrous or nonferrous terminals, lugs or fittings.



CONVERSION TABLES INCHES INTO MILLIMETERS

Phone: 800-521-3722

Fax: 864-877-2212

Email: cmw@cmwinc.com

To convert from inches to metric we are including the three tables below to allow conversion from inches into millimeters.

Examples:

From Table I **Convert 0.588 inches into millimeters**
 0.580 inches = 14.73 millimeters
 From Table I 0.008 inches = 0.203 millimeters
 Total 0.588 inches = 14.933 millimeters

From Table II **Convert 3.065 inches into millimeters**
 3 inches = 76.2002 millimeters
 From Table I 0.060 inches = 1.524 millimeters
 From Table I 0.005 inches = 0.127 millimeters
 Total 3.065 inches = 77.8512 millimeters

From Table II **Convert 2-51/64 inches into millimeters**
 2-25/32 inches = 70.6439 millimeters
 From Table II 1/64 inches = 0.3969 millimeters
 Total 2-51/64 inches = 71.0408 millimeters

**TABLE I
Decimals of
an inch into
millimeters**

Inches	Millimeters	Inches	Millimeters
0.001	0.025	0.460	11.68
0.002	0.051	0.470	11.94
0.003	0.076	0.480	12.19
0.004	0.102	0.490	12.45
0.005	0.127	0.500	12.70
0.006	0.152	0.510	12.95
0.007	0.178	0.520	13.21
0.008	0.203	0.530	13.26
0.009	0.229	0.540	13.72
0.010	0.254	0.550	13.97
0.020	0.508	0.560	14.22
		0.570	14.48
0.030	0.762	0.580	14.73
0.040	1.016	0.590	14.99
0.050	1.270	0.600	15.24
0.060	1.524	0.610	15.49
0.070	1.778	0.620	15.75
0.080	2.032	0.630	16.00
0.090	2.286	0.640	16.26
0.100	2.540	0.650	16.51
0.110	2.794	0.660	16.76
0.120	3.048	0.670	17.02
0.130	3.302	0.680	17.27
0.140	3.556	0.690	17.53
0.150	3.810	0.700	17.78
0.160	4.064	0.710	18.03
0.170	4.318	0.720	18.29
0.180	4.572	0.730	18.54
0.190	4.826	0.740	18.80
0.200	5.080	0.750	19.05
0.210	5.334	0.760	19.30
0.220	5.588	0.770	19.56
0.230	5.842	0.780	19.81
0.240	6.096	0.790	20.07
0.250	6.350	0.800	20.32
0.260	6.604	0.810	20.57
0.270	6.858	0.820	20.83
0.280	7.112	0.830	21.08
0.290	7.366	0.840	21.34
0.300	7.620	0.850	21.59
0.310	7.874	0.860	21.84
0.320	8.128	0.870	22.10
0.330	8.382	0.880	22.35
0.340	8.636	0.890	22.61
0.350	8.890	0.900	22.86
0.360	9.144	0.910	23.11
0.370	9.398	0.920	23.37
0.380	9.652	0.930	23.62
0.390	9.906	0.940	23.88
0.400	10.160	0.950	24.13
0.410	10.414	0.960	24.38
0.420	10.668	0.970	24.64
0.430	10.922	0.980	24.89
0.440	11.176	0.990	25.15
0.450	11.430	1.000	25.40

For Taper
Dimensions
in inches &
millimeters
see Page 7.

**TABLE II
Fractions of
an inch into
millimeters**

Inches	Millimeters	Inches	Millimeters
1/64	0.3969	33/64	13.0969
1/32	0.7937	17/32	13.4937
3/64	1.1906	35/64	13.8906
1/16	1.5875	9/16	14.2875
5/64	1.9844	37/64	14.6844
3/32	2.3812	19/32	15.0812
7/64	2.7781	39/64	15.4781
1/8	3.1750	5/8	15.8750
9/64	3.5719	41/64	16.2719
5/32	3.9687	21/32	16.6687
11/64	4.3656	43/64	17.0656
3/16	4.7625	11/16	17.4625
13/64	5.1594	45/64	17.8594
7/32	5.5562	23/32	18.2562
15/64	5.9531	47/64	18.6531
1/4	6.3500	3/4	19.0500
17/64	6.7469	49/64	19.4469
9/32	7.1437	25/32	19.8437
19/64	7.5406	51/64	20.2406
5/16	7.9375	13/16	20.6375
21/64	8.3344	53/64	21.0344
11/32	8.7312	27/32	21.4312
23/64	9.1281	55/64	21.8281
3/8	9.5250	7/8	22.2250
25/64	9.9219	57/64	22.6219
13/32	10.3187	29/32	23.0187
27/64	10.7156	59/64	23.4156
7/16	11.1125	15/16	23.8125
29/64	11.5094	61/64	24.2094
15/32	11.9062	31/32	24.6062
31/64	12.3031	63/64	25.0031
1/2	12.7000	1	25.4001

**TABLE III
Gage-Decimal-
Millimeter Conversion
Chart**

Gage	Decimal	Millimeter
3	.239	6.350
4	.234	5.953
5	.209	5.556
6	.194	5.159
7	.179	4.762
8	.164	4.365
9	.150	3.968
10	.135	3.571
11	.120	3.175
12	.105	2.778
13	.090	2.381
14	.075	1.984
15	.067	1.778
16	.060	1.587
17	.054	1.422
18	.048	1.270
19	.042	1.118
20	.036	.965
21	.033	.865
22	.030	.793
23	.027	.711
24	.024	.635
25	.021	.559
26	.018	.483
27	.016	.432
28	.015	.396
29	.014	.356
30	.012	.330
31	.011	.279
32	.010	.254
33	.009	.229
34	.0082	.216
35	.008	.203
36	.007	.178
37	.0064	.168
38	.006	.152

TAPER DIMENSIONS AND ELECTRODE CODING



Phone: 800-521-3722

Fax: 864-877-2212

Email: cmw@cmwinc.com

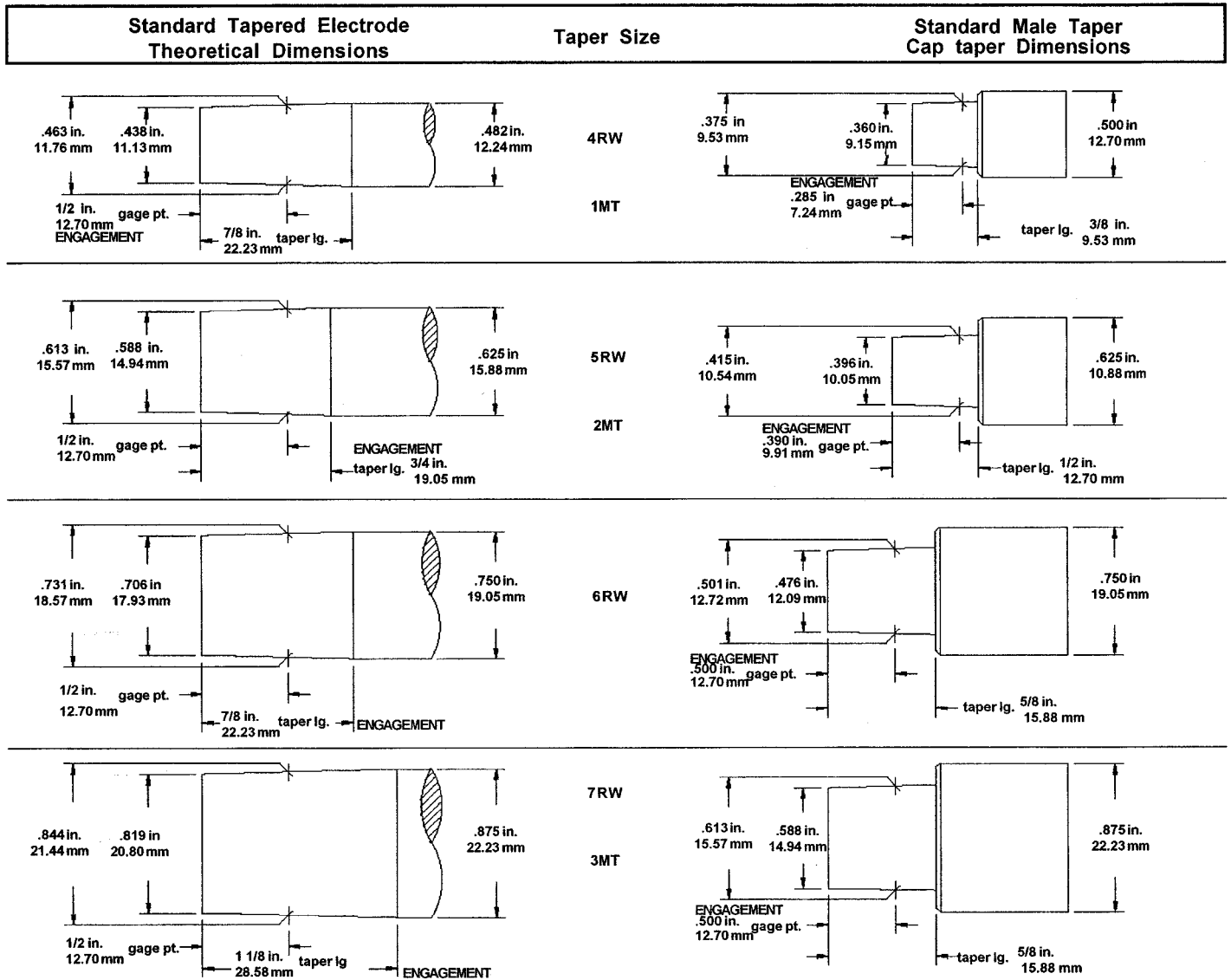

CMW CODING

FOR STRAIGHT TAPERED ELECTRODES

X X X X X

Material	Nose	Attachment	Length
1 = RWMA CLASS 1	1 = Dome	1 = No. 4RW	1 = 1"
3 = RWMA CLASS 2	2 = Pointed	No. 1MT	2 = 1 1/4"
	3 = Flat		3 = 1 1/2"
5 = RWMA CLASS 3	4 = Offset	2 = No. 5RW	4 = 1 3/4"
	5 = 2" Sph. R	No. 2MT	5 = 2"
6 = RWMA CLASS 11	6 = 10" Sph. R.		6 = 2 1/4"
	7 = Truncated	3 = No. 7RW	7 = 2 1/2"
8 = RWMA CLASS 13	8 = 3" Sph. R	No. 3MT	8 = 2 3/4"
	9 = 4" Sph. R		9 = 3"
9 = RWMA CLASS 14	0 = Shank for Male Cap	4 = No. 6RW	12 = 3 1/4"
			14 = 3 1/2"
Note: Prefix MP = Shank for Female Cap			16 = 3 3/4"
			18 = 4"
			20 = 4 1/4"
			22 = 4 1/2"

Drawings Full Size

RWMA CODING

FOR STRAIGHT TAPERED ELECTRODES

X X X X X

Nose	Material	Attachment	Length in no. of 1/4"
A = Pointed	1 = RWMA CLASS 1	4 = No. 4RW	04 = 1"
		No. 1MT	05 = 1 1/4"
B = Dome	2 = RWMA CLASS 2	5 = No. 5RW	06 = 1 1/2"
		No. 2MT	07 = 1 3/4"
C = Flat	3 = RWMA CLASS 3	6 = No. 6RW	08 = 2"
			09 = 2 1/4"
D = Offset		7 = No. 7RW	10 = 2 1/2"
		No. 3MT	11 = 2 3/4"
E = Truncated		8 = No. 8RW	12 = 3"
			13 = 3 1/4"
			14 = 3 1/2"
			15 = 3 3/4"
		16 = 4"	
		17 = 4 1/4"	
		18 = 4 1/2"	



CAP ELECTRODES

Phone: 800-521-3722

Fax: 864-877-2212

Email: cmw@cmwinc.com

These economical, quick change caps are made of long-lasting, highly-efficient Class 1, 2 and 2.18150 copper alloys, precision manufactured to exacting tolerances in a wide range of standard configurations or to your special requirements for use on CMW shanks.

- See pages 12 for Shanks

CMW FEMALE CAP ELECTRODES

ALL DIMENSIONS MARKED WITH AN (*) ARE COMMON TO EACH CAP IN A HORIZONTAL LINE.

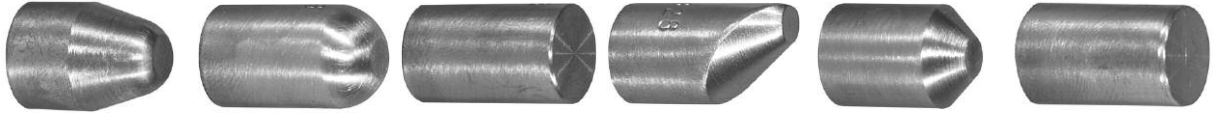

	POINTED (A)	DOME (B)	FLAT (C)	OFFSET (D)	TRUNCATED (E)	RADIUS (F)
Cap Taper RW #4 Diameter .500* Length .840* Class 1 Class 2 Class 2.18150	 $\varnothing.3945^*$ $\varnothing.188$	 $\varnothing.188$	 $\varnothing.500$	 $\varnothing.188$ 40°	 45° $\varnothing.188$	 $R=2.00''$
Class 1 Class 2 Class 2.18150	MPA14Z MPA24 MPA24Z	MPB14Z MPB24 MPB24Z	MPC14Z MPC24 MPC24Z	MPD14Z MPD24 MPD24Z	MPE14Z MPE24 MPE24Z	MPF14Z MPF24 MPF24Z
Cap Taper RW #5 Diameter .625* Length .880* Class 1 Class 2 Class 2.18150	 $\varnothing.4951^*$ $\varnothing.250$	 $\varnothing.188$	 $\varnothing.625$	 $\varnothing.250$ 40°	 45° $\varnothing.250$	 $R=2.00''$
Class 1 Class 2 Class 2.18150	MPA15Z MPA25 MPA25Z	MPB15Z MPB25 MPB25Z	MPC15Z MPC25 MPC25Z	MPD15Z MPD25 MPD25Z	MPE15Z MPE25 MPE25Z	MPF15Z MPF25 MPF25Z
Cap Taper RW #6 Diameter .750* Length 1.000* Class 1 Class 2 Class 2.18150	 $\varnothing.6255^*$ $\varnothing.313$	 $\varnothing.250$	 $\varnothing.750$	 $\varnothing.313$ 45°	 45° $\varnothing.313$	 $R=4.00''$
Class 1 Class 2 Class 2.18150	MPA16Z MPA26 MPA26Z	MPB16Z MPB26 MPB26Z	MPC16Z MPC26 MPC26Z	MPD16Z MPD26 MPD26Z	MPE16Z MPE26 MPE26Z	MPF16Z MPF26 MPF26Z

- See pages 13 for Shanks

CMW MALE CAP ELECTRODES

ALL DIMENSIONS MARKED WITH AN (*) ARE COMMON TO EACH CAP IN A HORIZONTAL LINE.



	POINTED (A)	DOME (B)	FLAT (C)	OFFSET (D)	TRUNCATED (E)	RADIUS (F)
Cap Taper RW #4 Diameter .500* Length 1.125* Class 1 Class 2 Class 2.18150	 $\varnothing.3745^*$ $\varnothing.188$ $.285^*$	 $\varnothing.188$	 $\varnothing.500$	 $\varnothing.188$ 40°	 45° $\varnothing.188$	 $R=2.00''$
Class 1 Class 2 Class 2.18150	MA14Z MA24 MA24Z	MB14Z MB24 MB24Z	MC14Z MC24 MC24Z	MD14Z MD24 MD24Z	ME14Z ME24 ME24Z	MF14Z MF24 MF24Z
Cap Taper RW #5 Diameter .625* Length 1.250* Class 1 Class 2 Class 2.18150	 $\varnothing.4145^*$ $\varnothing.250$ $.390^*$	 $\varnothing.188$	 $\varnothing.625$	 $\varnothing.250$ 40°	 45° $\varnothing.250$	 $R=2.00''$
Class 1 Class 2 Class 2.18150	MA15Z MA25 MA25Z	MB15Z MB25 MB25Z	MC15Z MC25 MC25Z	MD15Z MD25 MD25Z	ME15Z ME25 ME25Z	MF15Z MF25 MF25Z
Cap Taper RW #6 Diameter .750* Length 1.625* Class 1 Class 2 Class 2.18150	 $\varnothing.5005^*$ $\varnothing.313$ $.500^*$	 $\varnothing.250$	 $\varnothing.750$	 $\varnothing.313$ 45°	 45° $\varnothing.313$	 $R=4.00''$
Class 1 Class 2 Class 2.18150	MA16Z MA26 MA26Z	MB16Z MB26 MB26Z	MC16Z MC26 MC26Z	MD16Z MD26 MD26Z	ME16Z ME26 ME26Z	MF16Z MF26 MF26Z



The CMW GCAP® electrode is the answer to welding galvanized steels. The GCAP's® revolutionary design, and precision manufacturing from CMW Engineering provides for no sticking from the very first weld. GCAP® electrode nuggets meet or exceed industry standards for high quality welds from the first weld through the life of the cap. This cap design made from R.W.M.A. class 2 material eliminates brass build-up by literally rolling the brass away. You will use

less electric power (up to 25% less) and still achieve superior welds due to GCAP® design. Productivity will increase with up to 10 times more welds without dressing.

For best use of CMW GCAPS® a stepper program is recommended. Consult CMW application engineering.
U.S. Patent 49,954,687; 5,015,816; 5,126,528.
Other patents pending.

CMW FEMALE GCAP® ELECTRODES

ALL DIMENSIONS MARKED WITH AN (*) ARE COMMON TO EACH CAP IN A HORIZONTAL LINE.

- See pages 12 for Shanks
- See page 70 for suggested weld schedules



	STRAIGHT	OFFSET	OFFSET 15°	OFFSET 30°
Cap Taper RW #4 Diameter .500* Length .840* RWMA Class 2				
Cap Taper RW #5 Diameter .625* Length .880* RWMA Class 2				
Cap Taper RW #5 Diameter .625* Length .880* RWMA Class 2				
Cap Taper RW #6 Diameter .750* Length 1.000* RWMA Class 2				

CMW MALE GCAP® ELECTRODES

ALL DIMENSIONS MARKED WITH AN (*) ARE COMMON TO EACH CAP IN A HORIZONTAL LINE.

- See pages 13 for Shanks
- See page 70 for suggested weld schedules



	STRAIGHT	OFFSET	OFFSET 15°	OFFSET 30°
Cap Taper RW #4 Diameter .500* Length 1.125* RWMA Class 2				
Cap Taper RW #5 Diameter .625* Length 1.250* RWMA Class 2				
Cap Taper RW #5 Diameter .625* Length 1.250* RWMA Class 2				
Cap Taper RW #6 Diameter .750* Length 1.625* RWMA Class 2				



ASIAN CAP ELECTRODES

Phone: 800-521-3722

Fax: 864-877-2212

Email: cmw@cmwinc.com

These economical, quick change caps are made of long-lasting, highly-efficient Class 1, 2 and 2.18150 copper alloys, precision manufactured to exacting tolerances in a wide range of standard configurations or to your special requirements.

CMW FEMALE ASIAN CAP ELECTRODES

ALL DIMENSIONS MARKED WITH AN (*) ARE COMMON TO EACH CAP IN A HORIZONTAL LINE.



	ASIAN TYPE (D)	ASIAN TYPE (R)	ASIAN TYPE (F)	ASIAN TYPE (E)
Taper 1:9.6 Dia. 13mm (.512)* Length 20mm (.787)* Class 1 Class 2 Class 2.18150	<p>MPB141Z-01 MPB241-01 MPB241Z-04</p>	<p>MPB141Z-02 MPB241-02 MPB241Z-07</p>	<p>MPC141Z-01 MPC241-01 MPC241Z-02</p>	<p>MPD141Z-01 MPD241-02 MPD241Z-02</p>
Taper 1:9.6 Dia. 16mm (.625)* Length 23mm (.906)* Class 1 Class 2 Class 2.18150	<p>MPB15Z-11 MPB25-14 MPB25Z-19</p>	<p>MPB15Z-12 MPB25-18 MPB25Z-20</p>	<p>MPC15Z-01 MPC25-02 MPC25Z-05</p>	<p>MPD15Z-03 MPD25-05 MPD25Z-04</p>

METRIC-ISO 5821 STANDARD CAP ELECTRODES



Phone: 800-521-3722





Fax: 864-877-2212

Email: cmw@cmwinc.com

These economical, quick change caps are made of long-lasting, highly-efficient Class 2.18150 copper alloy, precision manufactured to exact tolerances in a wide range of standard configurations or to your special requirements.

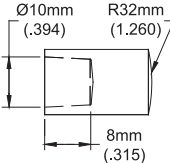
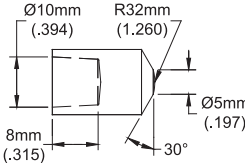
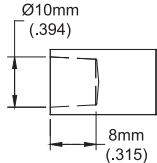
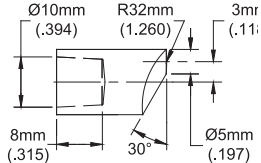
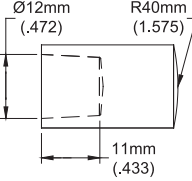
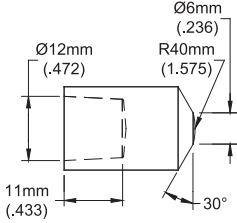
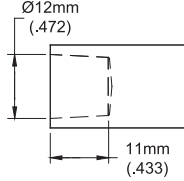
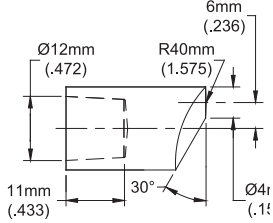

CMW FEMALE METRIC-ISO 5821 CAP ELECTRODES

ALL DIMENSIONS MARKED WITH AN (*) ARE COMMON TO EACH CAP IN A HORIZONTAL LINE.

	 METRIC TYPE (A)	 METRIC TYPE (B)	 METRIC TYPE (C)	 METRIC TYPE (D)
<p>Taper 1:10 Dia. 13mm (.512)* Length 18mm (.709)*</p> <p>Class 2.18150</p>	 <p>MPF241Z-01</p>	 <p>MPE241Z-01</p>	 <p>MPC241Z-01</p>	 <p>MPD241Z-01</p>
<p>Taper 1:10 Dia. 16mm (.625)* Length 20mm (.787)*</p> <p>Class 2.18150</p>	 <p>MPF25Z-01</p>	 <p>MPE25Z-02</p>	 <p>MPC25Z-02</p>	 <p>MPD25Z-02</p>

CMW FEMALE METRIC-ISO 5821 CAP ELECTRODES

ALL DIMENSIONS MARKED WITH AN (*) ARE COMMON TO EACH CAP IN A HORIZONTAL LINE.

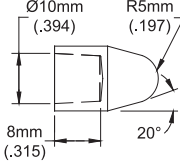
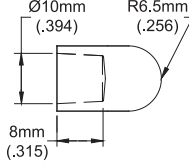
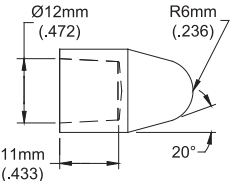
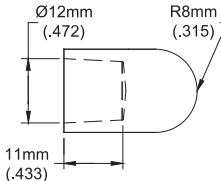
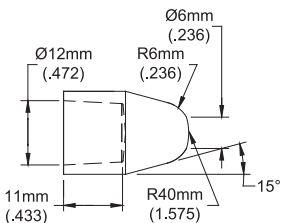
	 METRIC TYPE (E)	 METRIC TYPE (F)	 METRIC TYPE (G)
<p>Taper 1:10 Dia. 13mm (.512)* Length 18mm (.709)*</p> <p>Class 2.18150</p>	 <p>MPA241Z-01</p>	 <p>MPB241Z-01</p>	<p>No Standard Available</p>
<p>Taper 1:10 Dia. 16mm (.625)* Length 20mm (.787)*</p> <p>Class 2.18150</p>	 <p>MPA25Z-03</p>	 <p>MPB25Z-03</p>	 <p>MPA25Z-09</p>



SHANKS FOR FEMALE CAP ELECTRODES

Phone: 800-521-3722

Fax: 864-877-2212

Email: cmw@cmwinc.com

CMW shanks are precision manufactured from Class 2 material to provide a high quality mount for cap type electrodes. They are designed for high strength and electrical conductivity.

*These shanks are shown with a blind water hole for cap replacement without shutting off water. Shanks with through water holes are available, by adding "TH" to the basic part number. Example: MP30212TH.

- See pages 8 & 9 for CMW standard nose and GCAP® electrode caps

SHANKS FOR FEMALE CAP ELECTRODES



SHANKS FOR FEMALE CAPS WITH #4 RW TAPERS

BENT OFFSET SHANKS FOR FEMALE CAPS WITH #4 RW TAPERS

Part No.	A	B
MP3012	1.25	1.75
MP3013	1.50	2.00
MP3014	1.75	2.25
MP3015	2.00	2.50
MP3016	2.25	2.75
MP3017	2.50	3.00
MP3018	2.75	3.25
MP3019	3.00	3.50
MP30112	3.25	3.75
MP30114	3.50	4.00
MP30116	3.75	4.25
MP30118	4.00	4.50

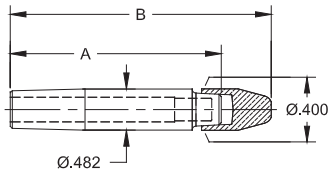

Part No.	A	B	C
MP3019-08	2.62	3.28	0.50
MP3019-12	2.56	3.22	0.75
MP30112-12	2.81	3.47	0.75
MP30112-16	2.37	3.03	1.00
MP30116-16	2.87	3.53	1.00
MP30116-20	2.60	3.28	1.25

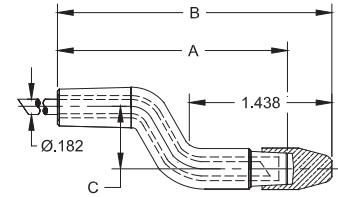

Bent Dimensions for Reference Only



SHANKS FOR FEMALE CAPS WITH #5 RW TAPERS

BENT OFFSET SHANKS FOR FEMALE CAPS WITH #5 RW TAPERS

Part No.	A	B
MP3023	1.46	2.00
MP3024	1.71	2.25
MP3025	1.96	2.50
MP3026	2.21	2.75
MP3027	2.46	3.00
MP3028	2.71	3.25
MP3029	2.96	3.50
MP30212	3.21	3.75
MP30214	3.46	4.00
MP30216	3.71	4.25
MP30218	3.96	4.50
MP30220	4.21	4.75
MP30222	4.46	5.00

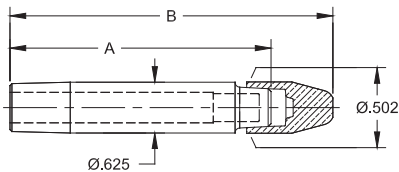

Part No.	A	B	C
MP3029-08	2.58	3.20	0.50
MP3029-12	2.60	3.12	0.75
MP30212-12	2.77	3.44	0.75
MP30212-16	2.33	3.00	1.00
MP30214-12	3.00	3.66	0.75
MP30214-16	2.81	3.48	1.00
MP30216-16	2.83	3.49	1.00
MP30216-20	2.77	3.43	1.25

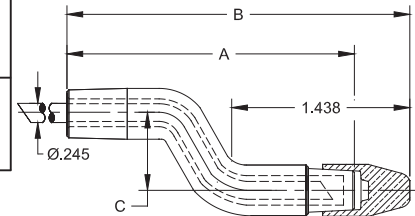

Bent Dimensions for Reference Only



SHANKS FOR FEMALE CAPS WITH #6 RW TAPERS

BENT OFFSET SHANKS FOR FEMALE CAPS WITH #6 RW TAPERS

Part No.	A	B
MP3044	1.64	2.25
MP3045	1.89	2.50
MP3046	2.14	2.75
MP3047	2.39	3.00
MP3048	2.64	3.25
MP3049	2.89	3.50
MP30412	3.14	3.75
MP30414	3.39	4.00
MP30416	3.64	4.25
MP30418	3.89	4.50
MP30420	4.14	4.75
MP30422	4.39	5.00

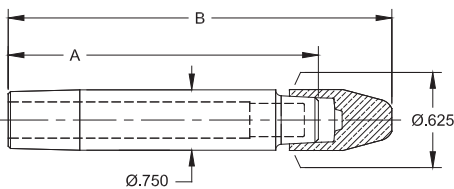

Part No.	A	B	C
MP3049-08	2.69	3.30	0.50
MP30412-12	2.81	3.42	0.75
MP30414-12	2.94	3.55	0.75
MP30416-16	3.06	3.67	1.00
MP30420-20	3.25	3.86	1.25

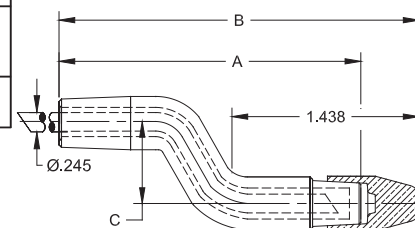

Bent Dimensions for Reference Only

SHANKS FOR MALE CAP ELECTRODES



Phone: 800-521-3722

Fax: 864-877-2212

Email: cmw@cmwinc.com

CMW shanks are precision manufactured from Class 2 material to provide a high quality mount for cap type electrodes. They are designed for high strength and electrical conductivity.

SHANKS FOR MALE CAP ELECTRODES

- See pages 8 & 9 for CMW standard nose and GCAP® electrode caps



SHANKS FOR MALE CAPS WITH #4 RW TAPERS

Part No.	A	B
3012	1.25	1.88
3013	1.50	2.12
3014	1.75	2.38
3015	2.00	2.62
3016	2.25	2.88
3017	2.50	3.12
3018	2.75	3.38
3019	3.00	3.62
30112	3.25	3.88
30114	3.50	4.12
30116	3.75	4.38
30118	4.00	4.62

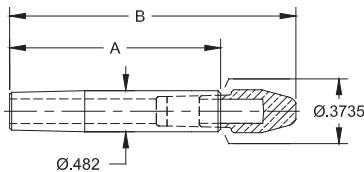

BENT OFFSET SHANKS FOR MALE CAPS WITH #4 RW TAPERS

Part No.	A	B	C
3019-08	2.62	3.37	0.50
3019-12	2.56	3.31	0.75
30112-12	2.81	3.56	0.75
30112-16	2.37	3.12	1.00
30116-16	2.87	3.62	1.00
30116-20	2.62	3.37	1.25

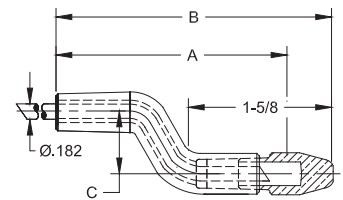

Bent Dimensions for Reference Only



SHANKS FOR MALE CAPS WITH #5 RW TAPERS

Part No.	A	B
3022	1.25	2.00
3023	1.50	2.25
3024	1.75	2.50
3025	2.00	2.75
3026	2.25	3.00
3027	2.50	3.25
3028	2.75	3.50
3029	3.00	3.75
30212	3.25	4.00
30214	3.50	4.25
30216	3.75	4.50
30218	4.00	4.75
30220	4.25	5.00
30222	4.50	5.25

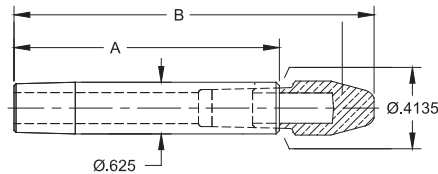

BENT OFFSET SHANKS FOR MALE CAPS WITH #5 RW TAPERS

Part No.	A	B	C
3028-08	2.37	3.12	0.50
3028-12	2.31	3.06	0.75
30212-12	2.81	3.56	0.75
30212-16	2.37	3.12	1.00
30214-12	3.06	3.81	0.75
30214-16	2.62	3.37	1.00
30214-20	2.37	3.12	1.25
30216-16	2.87	3.62	1.00
30216-20	2.62	3.37	1.25

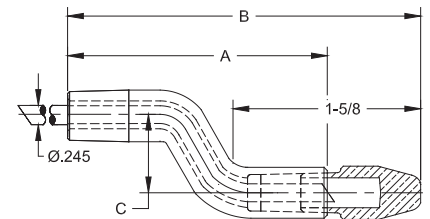

Bent Dimensions for Reference Only



SHANKS FOR MALE CAPS WITH #6 RW TAPERS

Part No.	A	B
3043	1.50	2.62
3044	1.75	2.88
3045	2.00	3.12
3046	2.25	3.38
3047	2.50	3.62
3048	2.75	3.88
3049	3.00	4.12
30412	3.25	4.38
30414	3.50	4.62
30416	3.75	4.88
30418	4.00	5.12
30420	4.25	5.38
30422	4.50	5.62

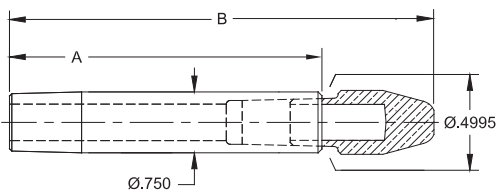

BENT OFFSET SHANKS FOR MALE CAPS WITH #6 RW TAPERS

Part No.	A	B	C
30412-08	2.62	3.75	0.50
30412-12	2.56	3.69	0.75
30414-12	2.75	3.88	0.75
30416-16	2.87	4.00	1.00
30420-20	3.12	4.25	1.25

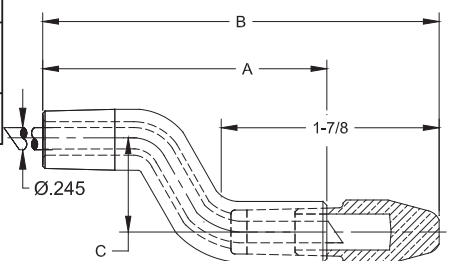

Bent Dimensions for Reference Only



DOME NOSE (B)

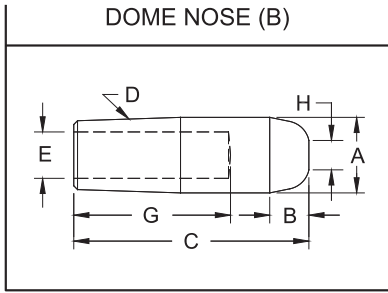

POINTED NOSE (A)

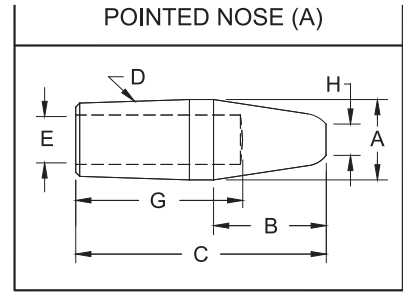

4 RW TAPER (D)			
RWMA Class 1	RWMA Class 2	RWMA Class 3	Nose Length B
1111	3111	5111	13/64
1112	3112	5112	1/4
1113	3113	5113	1/4
1114	3114	5114	1/4
1115	3115	5115	
1116	3116	5116	
1117	3117	5117	1/4
1118	3118	5118	
1119	3119	5119	
11112	31112	51112	1/4
11114	31114	51114	
11116	31116	51116	
11118	31118	51118	

COMMON DIMENSIONS				
Face Dia. H	Major Dia. A	Water Hole Dia. E	Overall Length C	Hole Depth G
3/16	.482	9/32	1	5/8
			1-1/4	3/4
			1-1/2	1
			1-3/4	1-1/4
			2	1-1/2
			2-1/4	1-3/4
			2-1/2	2
			2-3/4	2-1/4
			3	2-1/2
			3-1/4	2-3/4
			3-1/2	3
			3-3/4	3-1/4
4	3-1/2			

4 RW TAPER (D)			
RWMA Class 1	RWMA Class 2	RWMA Class 3	Nose Length B
1211	3211	5211	3/8
1212	3212	5212	3/8
1213	3213	5213	5/8
1214	3214	5214	3/4
1215	3215	5215	
1216	3216	5216	
1217	3217	5217	3/4
1218	3218	5218	
1219	3219	5219	
12112	32112	52112	3/4
12114	32114	52114	
12116	32116	52116	
12118	32118	52118	

5 RW TAPER (D)			
1122	3122	5122	3/8
1123	3123	5123	
1124	3124	5124	
1125	3125	5125	
1126	3126	5126	
1127	3127	5127	
1128	3128	5128	
1129	3129	5129	
11212	31212	51212	
11214	31214	51214	
11216	31216	51216	
11218	31218	51218	
11220	31220	51220	
11222	31222	51222	

COMMON DIMENSIONS				
1/4	.625	3/8	1-1/4	3/4
			1-1/2	3/4
			1-3/4	1
			2	1-1/4
			2-1/4	1-1/2
			2-1/2	1-3/4
			2-3/4	2
			3	2-1/4
			3-1/4	2-1/2
			3-1/2	2-3/4
			3-3/4	3
			4	3-1/4
4-1/4	3-1/2			
4-1/2	3-3/4			

5 RW TAPER (D)			
1222	3222	5222	1/2
1223	3223	5223	3/4
1224	3224	5224	3/4
1225	3225	5225	1-1/8
1226	3226	5226	
1227	3227	5227	
1228	3228	5228	1-1/8
1229	3229	5229	
12212	32212	52212	
12214	32214	52214	1-1/8
12216	32216	52216	
12218	32218	52218	
12220	32220	52220	
12222	32222	52222	1-1/8

*Electrodes of other tapers and alloys available upon request.

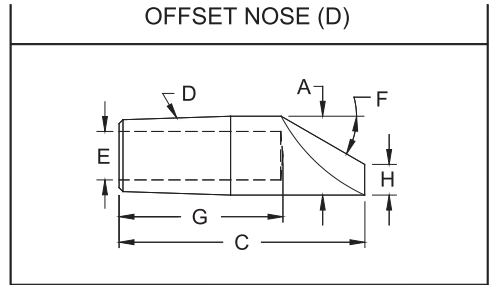
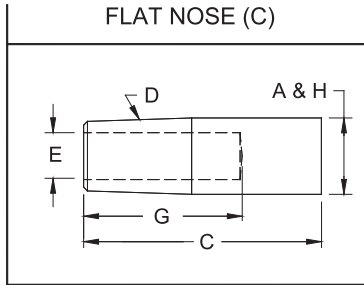

4 RW TAPER (D)			
RWMA Class 1	RWMA Class 2	RWMA Class 3	Face Dia. H
1311	3311	5311	.482
1312	3312	5312	
1313	3313	5313	
1314	3314	5314	
1315	3315	5315	
1316	3316	5316	
1317	3317	5317	
1318	3318	5318	
1319	3319	5319	
13112	33112	53112	
13114	33114	53114	
13116	33116	53116	
13118	33118	53118	

COMMON DIMENSIONS			
Major Dia. A	Water Hole Dia. E	Overall Length C	Hole Depth G
.482	9/32	1	5/8
		1-1/4	3/4
		1-1/2	1
		1-3/4	1-1/4
		2	1-1/2
		2-1/4	1-3/4
		2-1/2	2
		2-3/4	2-1/4
		3	2-1/2
		3-1/4	2-3/4
		3-1/2	3
		3-3/4	3-1/4
		4	3-1/2

4 RW TAPER (D)				
RWMA Class 1	RWMA Class 2	RWMA Class 3	Nose Angle F	Face Dia. H
1411	3411	5411	45°	3/16
1412	3412	5412	40°	
1413	3413	5413	30°	
1414	3414	5414	30°	
1415	3415	5415		
1416	3416	5416		
1417	3417	5417	30°	
1418	3418	5418		
1419	3419	5419		
14112	34112	54112	30°	
14114	34114	54114		
14116	34116	54116		
14118	34118	54118		

5 RW TAPER (D)			
RWMA Class 1	RWMA Class 2	RWMA Class 3	Face Dia. H
1322	3322	5322	5/8
1323	3323	5323	
1324	3324	5324	
1325	3325	5325	
1326	3326	5326	
1327	3327	5327	
1328	3328	5328	
1329	3329	5329	
13212	33212	53212	
13214	33214	53214	
13216	33216	53216	
13218	33218	53218	
13220	33220	53220	
13222	33222	53222	

COMMON DIMENSIONS			
Major Dia. A	Water Hole Dia. E	Overall Length C	Hole Depth G
.625	3/8	1-1/4	3/4
		1-1/2	3/4
		1-3/4	1
		2	1-1/4
		2-1/4	1-1/2
		2-1/2	1-3/4
		2-3/4	2
		3	2-1/4
		3-1/4	2-1/2
		3-1/2	2-3/4
		3-3/4	3
		4	3-1/4
		4-1/4	3-1/2
		4-1/2	3-3/4

5 RW TAPER (D)				
RWMA Class 1	RWMA Class 2	RWMA Class 3	Nose Angle F	Face Dia. H
1422	3422	5422	40°	1/4
1423	3423	5423	40°	
1424	3424	5424	30°	
1425	3425	5425	30°	
1426	3426	5426		
1427	3427	5427		
1428	3428	5428	30°	
1429	3429	5429		
14212	34212	54212		
14214	34214	54214	30°	
14216	34216	54216		
14218	34218	54218		
14220	34220	54220		
14222	34222	54222		

*Electrodes of other tapers and alloys available upon request.

TRUNCATED (E)									
RWMA	RWMA	RWMA	Major Dia. A	Overall Length C	Taper D	Hole Depth G	Face Dia. H	Water Hole Dia. E	
Class 1	Class 2	Class 3							
1712	3712	5712	.482	1-1/4	4RW	3/4	3/16	9/32	
1713	3713	5713		1-1/2		1			
1715	3715	5715		2		1-1/2			
1717	3717	5717	.625	2-1/2	5RW	2	1/4	3/8	
1718	3718	5718		2-3/4		2-1/4			
1723	3723	5723		1-1/2		3/4			
1725	3725	5725		2		1-1/4			
1727	3727	5727		2-1/2		1-3/4			
1729	3729	5729		3		2-1/4			
17218	37218	57218		4		3-1/4			

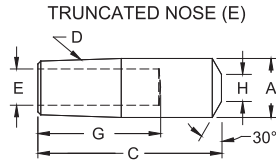

RADIUS (F)									
RWMA	RWMA	RWMA	Major Dia. A	Overall Length C	Taper D	Hole Depth G	Spherical Radius R	Water Hole Dia. E	
Class 1	Class 2	Class 3							
1523	3523	5523	.625	1-1/2	5RW	3/4	2	3/8	
1525	3525	5525		2		1-1/4			
1527	3527	5527		2-1/2		1-3/4			
1529	3529	5529	.625	3	5RW	2-1/4	10	3/8	
15218	35218	55218		4		3-1/4			
1623	3623	5623		1-1/2		3/4			
1625	3625	5625		2		1-1/4			
1627	3627	5627		2-1/2		1-3/4			
1629	3629	5629	.625	3	5RW	2-1/4	10	3/8	
16218	36218	56218		4		3-1/4			
1825	3825	5825		2		1-1/4			
1829	3829	5829		3		2-1/4			
1925	3925	5925		2		1-1/4			
1929	3929	5929		3		2-1/4			

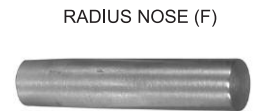
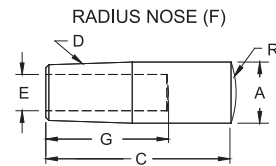

30° OFFSET									
RWMA	RWMA	RWMA	Major Dia. A	Overall Length C	Taper D	Hole Depth G	Face Dia. H	Water Hole Dia. E	
Class 1	Class 2	Class 3							
16-2491	16-2494		.482	2	4RW	1-1/2	1/4	9/32	
16-2492	16-2495		.625	2-1/2	5RW	2	3/8	3/8	
16-2493	16-2496		.875	3	7RW	2-1/4	1/2	1/2	

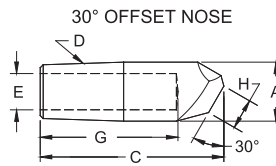

- See page 6 for Metric conversions, & See page 7 for Taper dimensions

REFRACTORY METAL FACED STRAIGHT ELECTRODES

COPPER-TUNGSTEN, MOLYBDENUM OR TUNGSTEN DOME									
10W Face	100M Face	100W Face	Major Dia. A	Nose Length B	Overall Length C	Taper D	Hole Depth G	Face Dia. H	Water Hole Dia. E
611050	811050	911050	.482	3/16	2	4RW	1-1/2	1/8	9/32
612050	812050	912050	.625	1/4		5RW			3/8

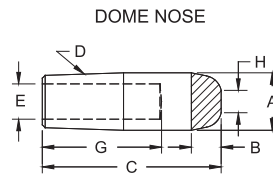

COPPER-TUNGSTEN, MOLYBDENUM OR TUNGSTEN FLAT NOSE									
RWMA	RWMA	RWMA	Major Dia. A	Nose Length B	Overall Length C	Taper D	Hole Depth G	Face Dia. H	Water Hole Dia. E
631050	831050	931050	.482	3/16	2	4RW	1-1/2	.482	9/32
632030			.625	1/4	1-1/2	5RW	1	5/8	3/8
632050	832050	932050		2	1-1/2				
632070				2-1/2	2				
16-1353				2-1/2			5/8		
633050	833050	933050	.875	1/4	2	7RW	1-1/2	7/8	1/2

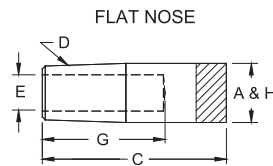

MOLYBDENUM OR TUNGSTEN INSERT NOSE									
RWMA	RWMA	RWMA	Major Dia. A	Nose Length B	Overall Length C	Taper D	Hole Depth G	Face Dia. H	Water Hole Dia. E
871050	971050		.482	3/8	2	4RW	1-1/2	3/16	9/32
872050	972050		.625	3/8	2	5RW	1-1/4	1/4	3/8

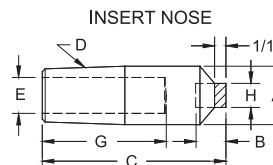

- Electrodes of other tapers and alloys available upon request. For other recommended material uses see page 4 and see chart on page 76. Electrodes faced with material other than those shown on this page are available to special order.

SINGLE BEND ELECTRODES



Phone: 800-521-3722

Fax: 864-877-2212

Email: cmw@cmwinc.com

RWMA CLASS 2 single bend electrodes are cold formed from full hard straight electrodes, and have properties superior to those obtained by casting or hot forging methods. Cooling tubes are bent in place, if requested, to provide water flow as near to the welding face as in the case of straight electrodes. These extra values assure you a more efficient, less costly electrode for gun welders and special offset welding applications.

Furnished with water tubes as specials to your order. Other nose types available to order. For dimensions not shown here see straight electrode (round water hole) measurements on page 14, 15, & 16. RWMA CLASS 1 material available on special order.

SINGLE BEND ELECTRODES



SINGLE BEND ELECTRODE

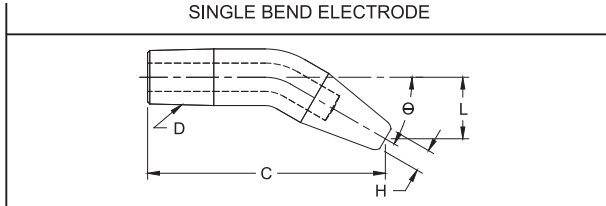

PART No.	Reference Length to ϕ of Face C	Taper D	Offset ϕ of Taper to ϕ of Face L	Bend Angle θ	Bend Weld Face Dia. H
3214-04-15	1-11/16		1/4	15°	3/16
3219-04-15	2-15/16	4 RW	1/4		
32118-13-15	3-7/8		13/16		
3225-04-15	1-7/8		1/4	30°	1/4
3229-04-15	2-7/8	5 RW	1/4		
32218-10-15	3-13/16		5/8		
3215-07-30	1-7/8		7/16	45°	3/16
3219-07-30	2-7/8	4 RW	7/16		
32118-23-30	3-5/8		1-7/16		
3226-09-30	2-1/16		9/16	60°	1/4
32212-09-30	3-1/16	5 RW	9/16		
32220-24-30	3-13/16		1-1/2		
3215-10-45	1-11/16		5/8	75°	3/16
32112-12-45	2-7/8	4 RW	3/4		
32118-33-45	3-1/8		2-1/16		
3228-17-45	2-1/4		1-1/16	90°	1/4
32214-17-45	3	5 RW	1-1/16		
32220-33-45	3-3/8		2-1/16		
3218-23-60	2		1-7/16	15°	3/16
32116-23-60	3	4 RW	1-7/16		
32118-40-60	2-5/8		2-1/2		
32212-25-60	2-3/8		1-9/16	30°	1/4
32218-25-60	3-1/8	5 RW	1-9/16		
32220-38-60	3		2-3/8		
32216-35-75	2-5/16		2-3/16	45°	3/16
32220-37-75	2-11/16	5 RW	2-5/16		
32220-43-75	2-3/8		2-11/16		

Bend dimensions are for reference only



90° RADIUS BEND ELECTRODE

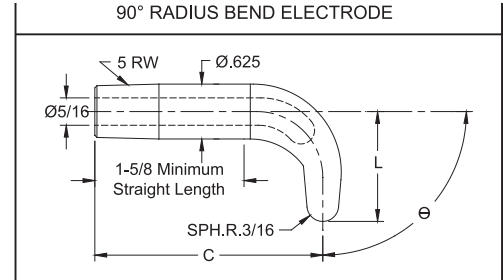

15° RADIUS BEND ELECTRODE

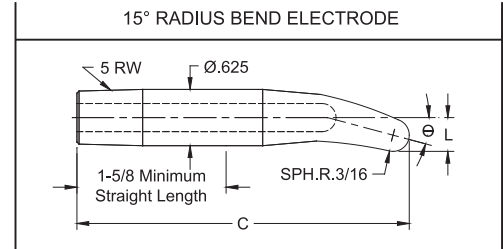

PART No.	O.A.L. C	Offset ϕ of Taper to Top of Radius L	Bend Angle θ
16-26015	3-11/16	3/8	15°
16-26030	3-5/8	33/64	30°
16-26045	3-1/2	43/64	45°
16-26060	3-3/8	27/32	60°
16-26075	3-7/64	1-1/32	75°
16-26090	2-13/16	1-1/4	90°

Radius bend electrodes are designed for use with 18-768 & 18-784 straight universal adapters shown on page 46.

- See page 6 for Metric Conversion
- See page 7 for Taper Dimensions

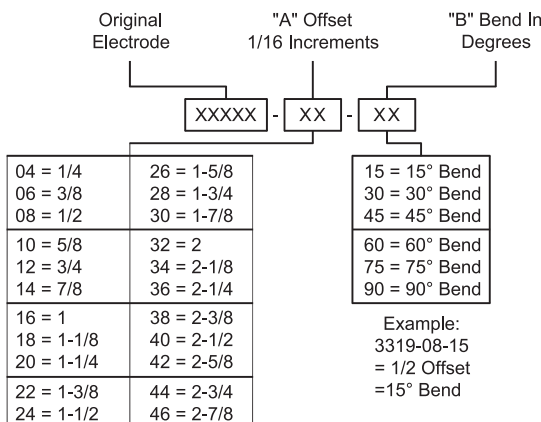

SINGLE BEND ELECTRODE CODING SYSTEM

For electrodes not listed

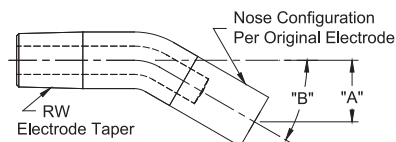



DOUBLE BEND ELECTRODES

Phone: 800-521-3722

Fax: 864-877-2212

Email: cmw@cmwinc.com

Offset D	Taper Size	Nose End N	Taper End T	Dome, Pointed & Flat, O.A.L. C	Pointed Nose Part No.	
1/2	4 RW	3/4	7/8	2	321-0832-23	
		3/4	7/8	2-1/2	321-0840-23	
		2	7/8	3-1/4	321-0852-93	
	5 RW	1	1	2-1/2	322-0840-44	
		1	1	2-3/4	322-0844-44	
		2	1	3-1/2	322-0856-94	
3/4	4 RW	3/4	7/8	2	321-1232-23	
		3/4	7/8	2-1/2	321-1240-23	
		2	7/8	3-1/2	321-1256-93	
	5 RW	1	1	2-3/4	322-1244-44	
		1	1	3	322-1248-44	
		2	1	3-1/2	322-1256-94	
1	4 RW	3/4	7/8	2-1/4	321-1636-23	
		3/4	7/8	2-3/4	321-1644-23	
		1-3/4	7/8	3-1/4	321-1652-83	
		3/4	7/8	3-1/2	321-1656-23	
	5 RW	1	1	2-3/4	322-1644-44	
		1	1	3	322-1648-44	
		1	1	3-1/2	322-1656-44	
		1-3/4	1	3-1/2	322-1656-84	
	1-1/4	4 RW	3/4	7/8	2-1/2	321-2040-23
			3/4	7/8	3	321-2048-23
			1-1/2	7/8	3	321-2048-73
		5 RW	1	1	2-3/4	322-2044-44
1			1	3-1/4	322-2052-44	
1-1/2			1	3-1/2	322-2056-44	
1-1/2	5 RW	1	1	2-3/4	322-2444-44	
		1-1/4	1	3	322-2448-64	
		1	1	2-3/4	322-2844-44	
		1-1/4	1	3	322-2848-64	

DOUBLE BEND ELECTRODES

CMW double bend electrodes are cold formed from full hard straight electrodes, and have properties superior to those obtainable by casting or hot forging methods. Cooling tubes, unless otherwise specified are bent in place to provide coolant flow near the welding face as in the case of straight electrodes. These extra values assure you of longer electrode life, longer runs between dressings, and highest weld quality. RWMA CLASS 2 material is standard for these electrodes. RWMA CLASS 1 or CLASS 3, available on special order.

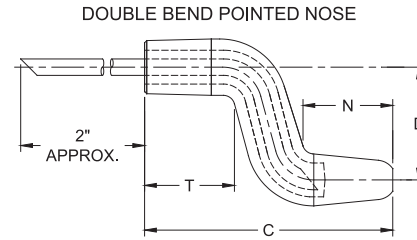

Bent dimensions are for reference only



Water Tube Sizes:
4RW = .182 O.D.
5RW = .245 O.D.

DOUBLE BEND ELECTRODE CODING SYSTEM

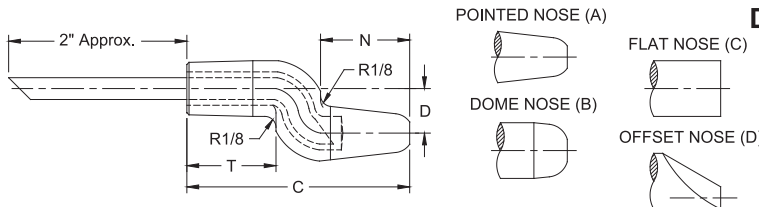

EXAMPLE:
322-0840-44

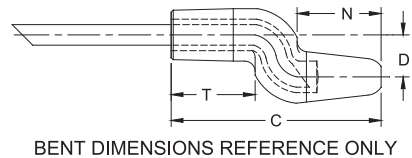
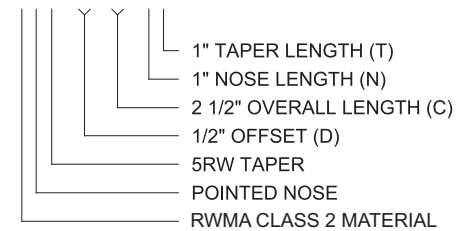

Offset (D) Overall Length (C) Nose Length (N) Taper Length (T) Optional Without Water Tube

Taper Nose Material

X X X - X X X - X X X - X X Z

1 = CLASS 1	1 = DOME	1 = 4RW 1MT	08 = 1/2"	32 = 2"	2 = 3/4"
3 = CLASS 2	2 = *POINTED	2 = 5RW 2MT	12 = 3/4"	36 = 2 1/4"	3 = 7/8"
5 = CLASS 3	3 = FLAT		16 = 1"	40 = 2 1/2"	4 = 1"
*Standard	4 = OFFSET		20 = 1 1/4"	44 = 2 3/4"	** 5 = 1 1/8"
			24 = 1 1/2"	48 = 3"	** 6 = 1 1/4"
			28 = 1 3/4"	52 = 3 1/4"	** 7 = 1 1/2"
				56 = 3 1/2"	** 8 = 1 3/4"
				60 = 3 3/4"	** 9 = 2"

Water Tube Sizes:
4RW = .182 O.D.
5RW = .245 O.D.

**May not be a stock item

Standard 4RW nose length = 3/4"

Standard 4RW taper length = 7/8"

Standard 5RW nose & taper length = 1"

- See Page 6 for Metric Conversion
- See Page 7 for Taper Dimensions

CRANK ELECTRODES - COLD FORMED



Phone: 800-521-3722

Fax: 864-877-2212

Email: cmw@cmwinc.com

FEATURES AND SPECIFICATIONS

- Very strong bend electrodes for higher force applications
- Bent & Offset electrodes are for hard to reach locations
- Long lasting heavy duty electrodes

- Works with all industry standard holders
- Use with 4 & 5 R.W.M.A Holders
- Bent dimensions are for reference only

- Electrical conductivity up to 85% IACS for cold formed crank electrodes
- Rockwell hardness up to 83 HRB for cold formed crank electrodes

CRANK ELECTRODES - COLD FORMED

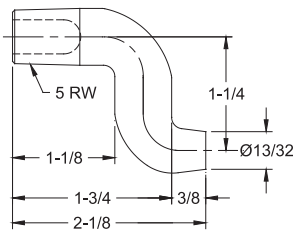

16-38661 RWMA CLASS 2
COLD FORMED*

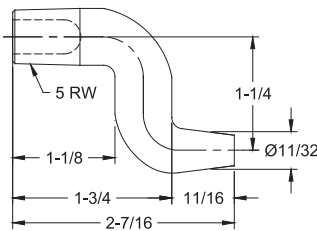

16-38666 RWMA CLASS 2
COLD FORMED*

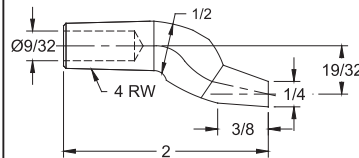

16-3870 RWMA CLASS 2
COLD FORMED*

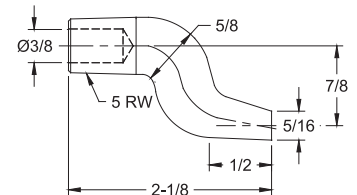

16-3871 RWMA CLASS 2
COLD FORMED*

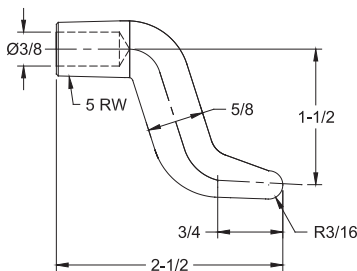

16-38351 RWMA CLASS 2
COLD FORMED*

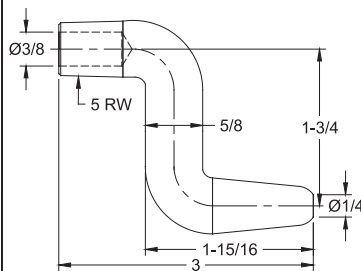

16-38352 RWMA CLASS 2
COLD FORMED*

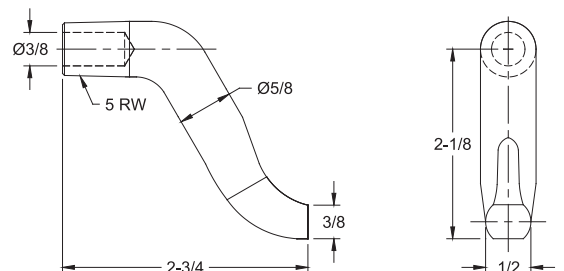

16-38353 RWMA CLASS 2
COLD FORMED*

*Optional materials RWMA CLASS 1 and CLASS 3 available on special order



CRANK ELECTRODES - CASTINGS, FORGED

Phone: 800-521-3722

Fax: 864-877-2212

Email: cmw@cmwinc.com

FEATURES AND SPECIFICATIONS

- Very strong bend electrodes for higher force applications
- Offset electrodes are for hard to reach locations
- Long lasting heavy duty electrodes

- Can be used in many job shop applications
- Works with all industry standard holders
- Use with 4 & 5 R.W.M.A Holders

- Electrical conductivity up to 80% IACS for castings & forged crank electrodes
- Rockwell hardness up to 70 HRB for castings & forged crank electrodes

CRANK ELECTRODES - CASTING, FORGED

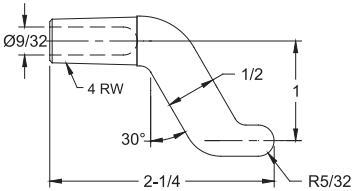

16-3835 RWMA CLASS 2 CASTING

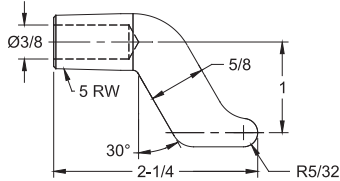

16-3836 RWMA CLASS 2 CASTING

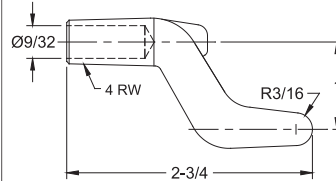

16-3837 RWMA CLASS 2 CASTING

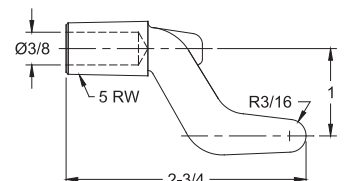

16-3838 RWMA CLASS 2 CASTING

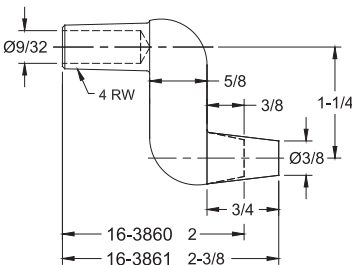

RWMA CLASS 2 FORGED

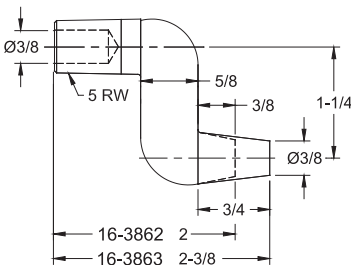

RWMA CLASS 2 FORGED

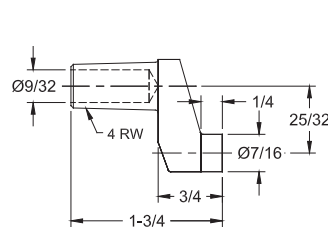

16-3873 RWMA CLASS 2 CASTING

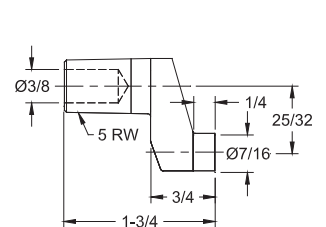

16-3874 RWMA CLASS 2 CASTING



Phone: 800-521-3722

Fax: 864-877-2212

Email: cmw@cmwinc.com

- See page 6 for
Metric Conversions
- See page 7 for
Taper Dimensions

SPADE ELECTRODES



Bent Dimensions for Reference Only

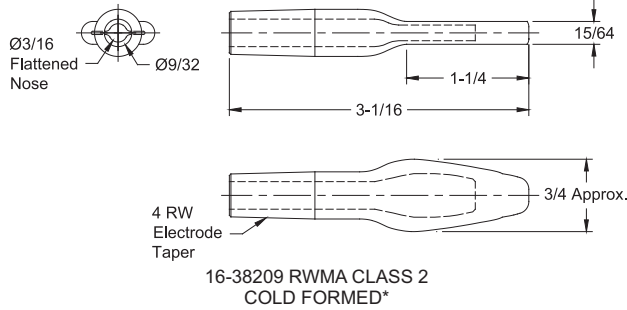

Bent Dimensions for Reference Only

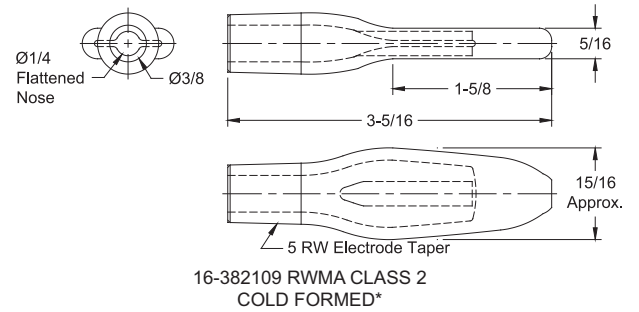

Bent Dimensions for Reference Only

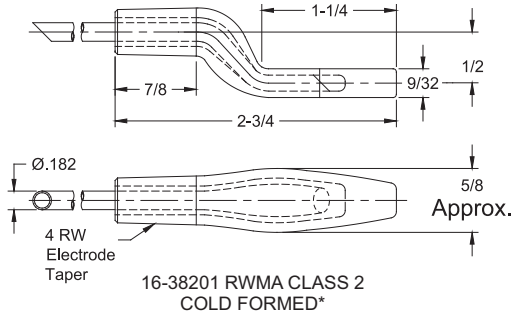

Bent Dimensions for Reference Only

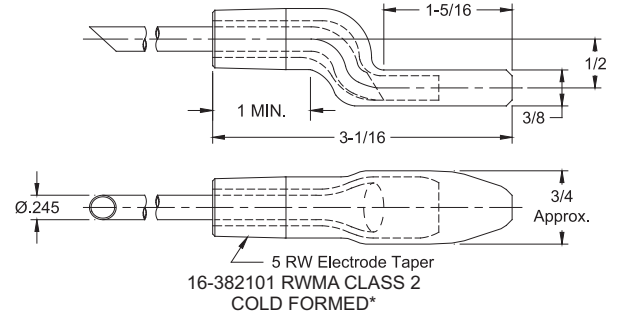

Bent Dimensions for Reference Only

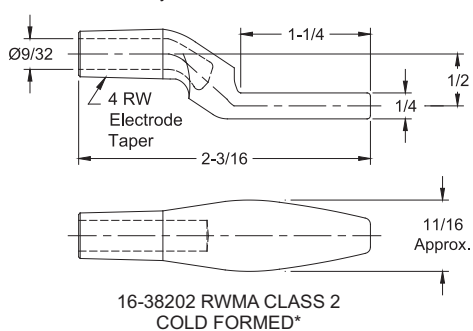

Bent Dimensions for Reference Only

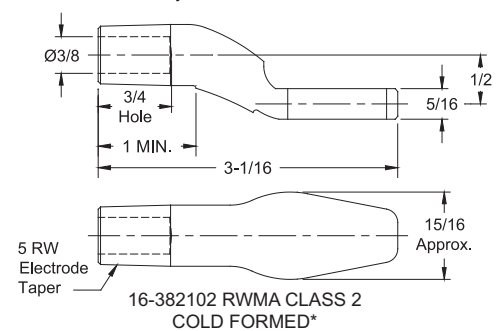

*Optional material available on special order: RWMA CLASS 1 and CLASS 3



GUN ELECTRODES

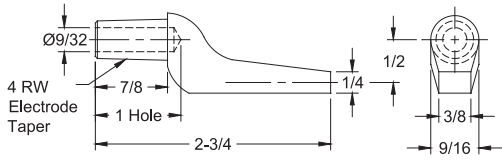

16-3820 RWMA CLASS 2
CASTING

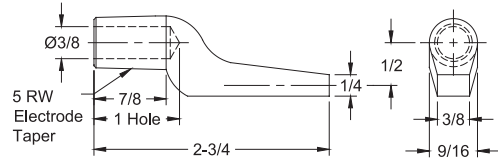

16-3821 RWMA CLASS 2
CASTING



Bent Dimensions for Reference Only

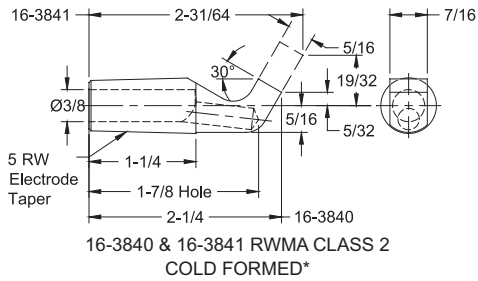

16-3840 & 16-3841 RWMA CLASS 2
COLD FORMED*

Bent Dimensions for Reference Only

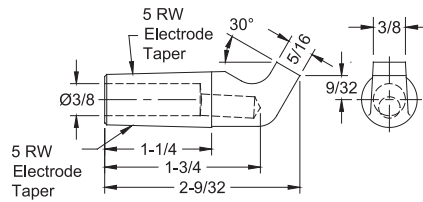

16-3847 RWMA CLASS 2
COLD FORMED*

*Optional material RWMA CLASS 1 and CLASS 3 available on special order.

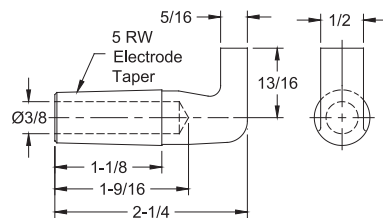

16-382120 RWMA CLASS 2
CASTING

- See page 6 for
Metric Conversions
- See page 7 for
Taper Dimensions

CHAMELEON/MAX-LIFE™ NUT WELDING ELECTRODES



Phone: 800-521-3722

Fax: 864-877-2212

Email: cmw@cmwinc.com

CHAMELEON/MAX-LIFE™ NUT WELDING ELECTRODES

RWMA CLASS 2 Base Spring Pin 10W Faced Cap

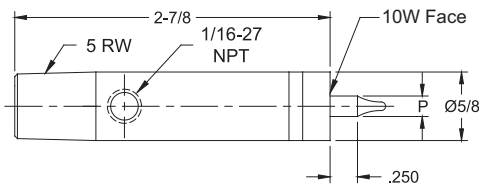
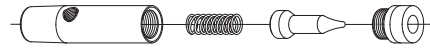

Nut Welding Assemblies	Nut Thread Size	Pin Dia. P	RWMA CLASS 2 Base	Spring	Ceramic Coated Steel Pin	10W Faced Cap
16-37725-04	#4	.142	16-37325	16-950078-01	16-950064-04	16-37725-C04
16-37725-05	#5	.158	16-37325	16-950078-01	16-950064-05	16-37725-C05
16-37725-06	#6	.173	16-37325	16-950078-01	16-950064-06	16-37725-C06
16-37725-M4	4MM	.187	16-37325	16-950078-01	16-950064-M4S	16-37725-CM4
16-37725-08	#8	.198	16-37325	16-950078-01	16-950064-08	16-37725-C08
16-37725-10	#10	.220	16-37325	16-950078-01	16-950064-10	16-37725-C10
16-37725-M5	5MM	.226	16-37325	16-950078-01	16-950064-M5S	16-37725-CM5
16-37725-12	#12	.250	16-37325	16-950078-01	16-950064-12	16-37725-C12
16-37725-M6	6MM	.266	16-37325	16-950078-01	16-950064-M6S	16-37725-CM6
16-37725-25	.250	.283	16-37325	16-950078-01	16-950064-25	16-37725-C25

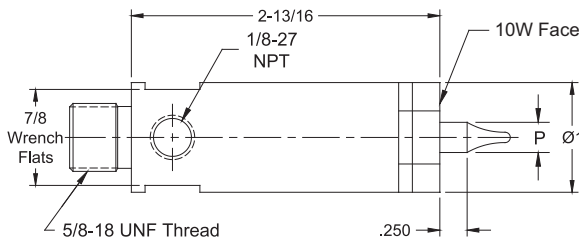

RWMA CLASS 2 Base Spring Pin 10W Faced Cap

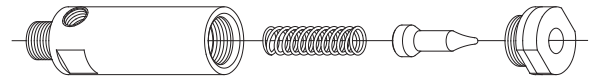

Nut Welding Assemblies	Nut Thread Size	Pin Dia. P	RWMA CLASS 2 Base	Spring	Ceramic Coated Steel Pin	10W Faced Cap
16-37825-M4	4MM	.187	16-37825	16-950065-01	16-950064-M4	16-37825-CM4
16-37825-M5	5MM	.226	16-37825	16-950065-01	16-950064-M5	16-37825-CM5
16-37825-M6	6MM	.266	16-37825	16-950065-01	16-950064-M6	16-37825-CM6
16-37825-M7	7MM	.305	16-37825	16-950065-01	16-950064-M7	16-37825-CM7
16-37825-M8	8MM	.344	16-37825	16-950065-01	16-950064-M8	16-37825-CM8
16-37825-M9	9MM	.384	16-37825	16-950065-01	16-950064-M9	16-37825-CM9

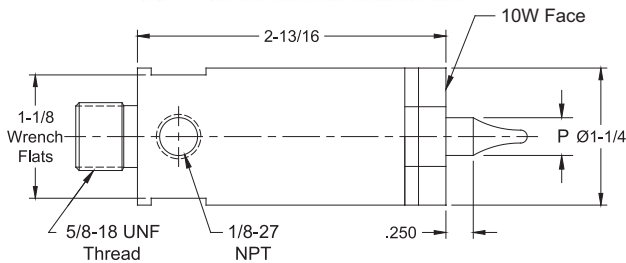

RWMA CLASS 2 Base Spring Pin 10W Faced Cap

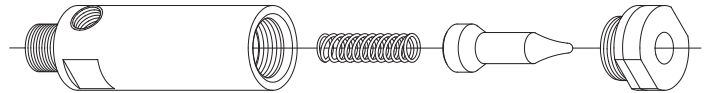

Nut Welding Assemblies	Nut Thread Size	Pin Dia. P	RWMA CLASS 2 Base	Spring	Ceramic Coated Steel Pin	10W Faced Cap
16-37826-M10	10MM	.423	16-37826	16-950065-01	16-950064-M10	16-37826-CM10
16-37826-M11	11MM	.463	16-37826	16-950065-01	16-950064-M11	16-37826-CM11
16-37826-M12	12MM	.502	16-37826	16-950065-01	16-950064-M12	16-37826-CM12
16-37826-M14	14MM	.581	16-37826	16-950065-01	16-950064-M14	16-37826-CM14

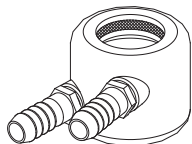

External Electrode Cooling Chamber

Electrode Dia.	Cooling Chamber Part No.	Tapered Adapter Part No.
5/8	18-1340	--
1	18-1342	18-7741
1-1/4	18-1343	18-7742

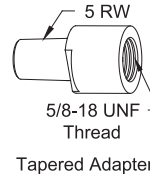

Tapered Adapter

- Electrode Assemblies 16-37825-XX and 16-37826-XXX may be used with 5/8-18 threaded holders 18-169, 18-170, 18-171, shown on page 32

- Electrode Assemblies 16-37825-XX and 16-37826-XXX may be used with Platen Mounted holders (page 49) by using adapter 18-7743 shown on page 31

All dimensions are in inches unless otherwise noted

CHAMELEON/MAX-LIFE™ STUD WELDING ELECTRODES

Phone: 800-521-3722

Fax: 864-877-2212

Email: cmw@cmwinc.com

CHAMELEON/MAX-LIFE™ STUD WELDING ELECTRODES

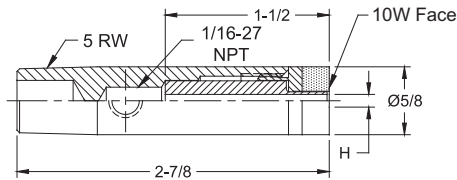
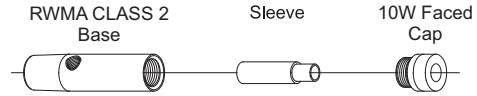

Stud Welding Assemblies	Screw Thread Size	Sleeve I.D. H	RWMA CLASS 2 Base	Ceramic Coated Steel Sleeve	10W Faced Cap
16-37325-116	#4	.116	16-37325	16-953116	16-37325-C116
16-37325-132	#5	.132	16-37325	16-953132	16-37325-C132
16-37325-140	#6	.140	16-37325	16-953140	16-37325-C140
16-37325-169	#8	.169	16-37325	16-953169	16-37325-C169
16-37325-169	4MM	.169	16-37325	16-953169	16-37325-C169
16-37325-191	#10	.191	16-37325	16-953191	16-37325-C191
16-37325-204	5MM	.204	16-37325	16-953204	16-37325-C204
16-37325-220	#12	.220	16-37325	16-953220	16-37325-C220
16-37325-243	6MM	.243	16-37325	16-953243S	16-37325-C243
16-37325-254	.250	.254	16-37325	16-953254S	16-37325-C254

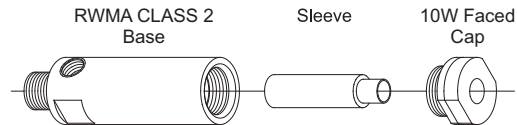
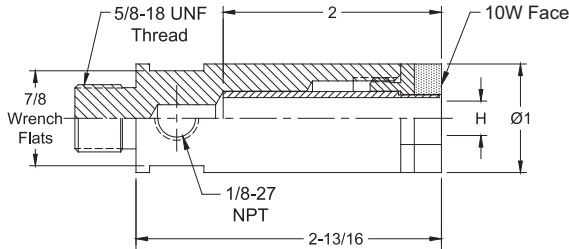
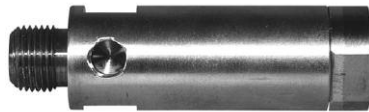

Stud Welding Assemblies	Screw Thread Size	Sleeve I.D. H	RWMA CLASS 2 Base	Ceramic Coated Steel Sleeve	10W Faced Cap
16-37525-243	6MM	.243	16-37825	16-953243	16-37525-C243
16-37525-254	.250	.254	16-37825	16-953254	16-37525-C254
16-37525-320	.312	.320	16-37825	16-953320	16-37525-C320
16-37525-320	8MM	.320	16-37825	16-953320	16-37525-C320
16-37525-380	.375	.380	16-37825	16-953380	16-37525-C380

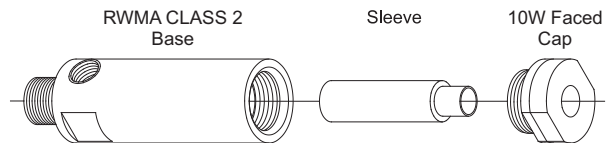
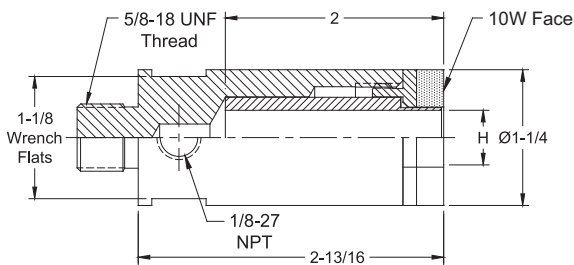
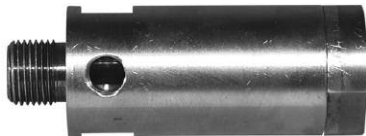

Stud Welding Assemblies	Screw Thread Size	Sleeve I.D. H	RWMA CLASS 2 Base	Ceramic Coated Steel Sleeve	10W Faced Cap
16-37526-399	10MM	.399	16-37526	16-953399	16-37526-C399
16-37526-444	.438	.444	16-37526	16-953444	16-37526-C444
16-37526-477	12MM	.477	16-37526	16-953477	16-37526-C477
16-37526-502	.500	.502	16-37526	16-953502	16-37526-C502
16-37526-630	.625	.630	16-37526	16-953630	16-37526-C630

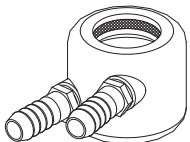

External Electrode Cooling Chamber

Electrode Dia.	Cooling Chamber Part No.	Tapered Adapter Part No.
5/8	18-1340	--
1	18-1342	18-7741
1-1/4	18-1343	18-7742

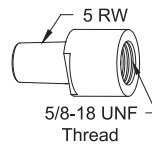

Tapered Adapter

- Electrode Assemblies 16-37525-XXX and 16-37526-XXX may be used with 5/8-18 threaded holders 18-169, 18-170, 18-171, shown on page 32

- Electrode Assemblies 16-37525-XXX and 16-37526-XXX may be used with Platen Mounted holders (page 49) by using adapter 18-7743 shown on page 31

SELF-PILOTING NUT WELDING ELECTRODES



Phone: 800-521-3722

Fax: 864-877-2212

Email: cmw@cmwinc.com

SELF-PILOTING NUT WELDING ELECTRODES



PART No.	Taper Size	Pin Dia. N	For Nut Thread Size	Pin Length L
16-3764-04	5 RW	.082	#4	.093
16-3764-05		.093	#5	
16-3764-06		.100	#6	
16-3764-M3.5		.107	3.5 MM	
16-3764-M4	5 RW	.123	4.0 MM	.156
16-3764-08		.129	#8	
16-3764-10		.143	#10	
16-3764-M5		.156	5.0 MM	

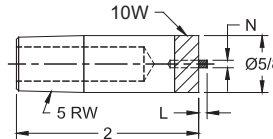

FEATURES AND SPECIFICATIONS

- 10W faced RWMA CLASS 2 material
- Insulated pin made of anodized aluminum
- Pins are treated to 55 HRC for wear resistance
- Use with tapered electrode holders
- Use with flat faced electrodes



PART No.	Taper Size	Pin Dia. N	For Nut Thread Size	Pin Length L
16-3765-12	5 RW	.166	#12	.375
16-3765-M6		.189	6.0 MM	
16-3765-25		.192	1/4	
16-3765-M7		.223	7.0 MM	
16-3765-M8	5 RW	.252	8.0 MM	.375
16-3765-31		.257	5/16	
16-3765-M9		.291	9.0 MM	

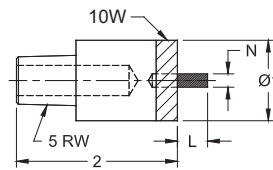

TYPICAL SET-UP FOR SELF PILOTING NUTS

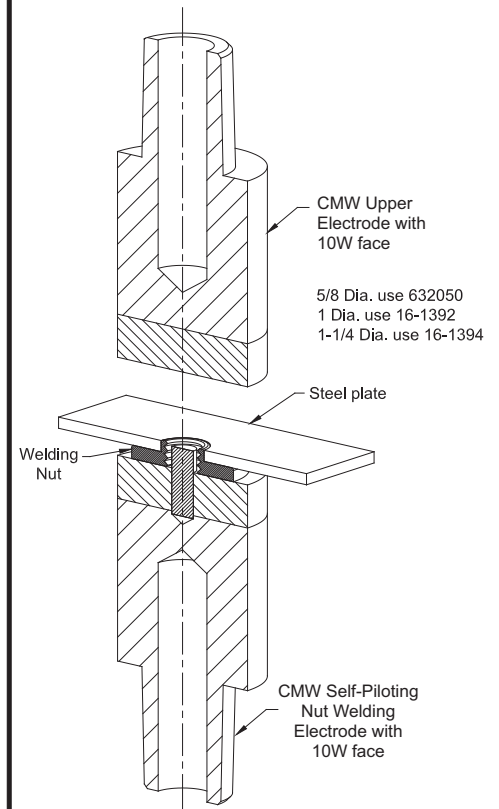

PART No.	Taper Size	Pin Dia. N	For Nut Thread Size	Pin Length L
16-3766-38	5 RW	.306	3/8	.375
16-3766-M10		.320	10 MM	
16-3766-M11		.359	11 MM	
16-3766-44		.361	7/16	
16-3766-M12	5 RW	.388	12 MM	.375
16-3766-50		.415	1/2	
16-3766-M14		.455	14 MM	

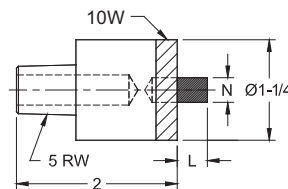

- See page 6 for Metric conversions
- See page 7 for Taper dimensions



NON-PILOTING NUT WELDING ELECTRODES

Phone: 800-521-3722

Fax: 864-877-2212

Email: cmw@cmwinc.com

NON-PILOTING NUT WELDING ELECTRODES



PART No.	Taper or Thd. Size	Pin Dia. N	Pilot Length L	Pilot Dia. P	For Nut Thd. Size N	Pin Part No.
16-3774-04		.082		.142	#4	16-950001-04
16-3774-05		.093		.158	#5	16-950001-05
16-3774-06		.100		.173	#6	16-950001-06
16-3774-08	5RW	.129	.312	.198	#8	16-950001-08
16-3774-10		.143		.220	#10	16-950001-10
16-3774-M6		.186		.250	6MM	16-950001-M6

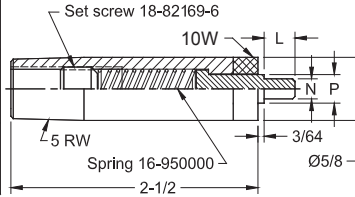

PART No.	Taper or Thd. Size	Pin Dia. N	Pilot Length L	Pilot Dia. P	For Nut Thd. Size N	Pin Part No.
16-3775-12		.166		.250	#12	16-950001-12
16-3775-M6		.186		.250	6MM	16-950001-M6
16-3775-25		.192		.283	1/4	16-950001-25
16-3775-M8	5RW	.252	.312	.283	8MM	16-950001-M8
16-3775-31		.257		.345	5/16	16-950001-31
16-3775-M10		.322		.347	10MM	16-950001-M10

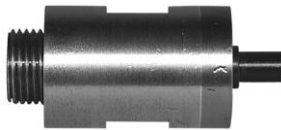
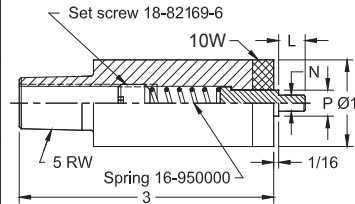

PART No.	Taper or Thd. Size	Pin Dia. N	Pilot Length L	Pilot Dia. P	For Nut Thd. Size N	Pin Part No.
16-3785-12	5/8-18	.166	.375	.250	#12	16-950002-12
16-3785-M6		.186		.269	6MM	16-950002-M6
16-3785-25		.192		.283	1/4	16-950002-25
16-3785-M8		.252		.348	8MM	16-950002-M8
16-3785-31		.257		.345	5/16	16-950002-31
16-3785-M10		.320		.427	10MM	16-950002-M10
16-3785-M11		.359		.466	11MM	16-950002-M11
16-3785-M12		.388		.470	12MM	16-950002-M12

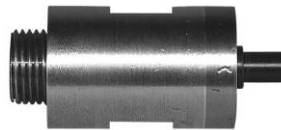
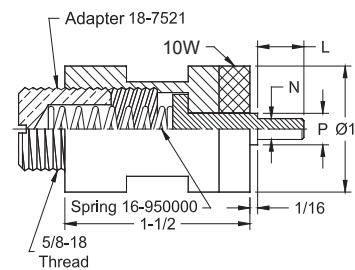

PART No.	Taper or Thd. Size	Pin Dia. N	Pilot Length L	Pilot Dia. P	For Nut Thd. Size N	Pin Part No.
16-3786-12	5/8-18	.166	.375	.250	#12	16-950002-12
16-3786-M6		.186		.269	6MM	16-950002-M6
16-3786-25		.192		.283	1/4	16-950002-25
16-3786-M8		.252		.348	8MM	16-950002-M8
16-3786-31		.257		.345	5/16	16-950002-31
16-3786-38		.306		.408	3/8	16-950002-38
16-3786-M10		.320		.427	10MM	16-950002-M10
16-3786-M11		.359		.466	11MM	16-950002-M11
16-3786-44		.361		.470	7/16	16-950002-44
16-3786-M12		.388		.470	12MM	16-950002-M12
16-3786-50		.415		.533	1/2	16-950002-50

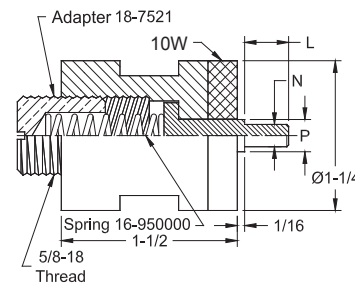

FEATURES AND SPECIFICATIONS

- 10W faced RWMA CLASS 2 material
- Insulated pin made of anodized aluminum
- Insulated pins are treated to 55 HRC for wear resistance
- Use with tapered electrode holders
- Use with flat faced electrodes
- Accepts external cooling chambers

TYPICAL SET-UP FOR NON PILOTING NUTS

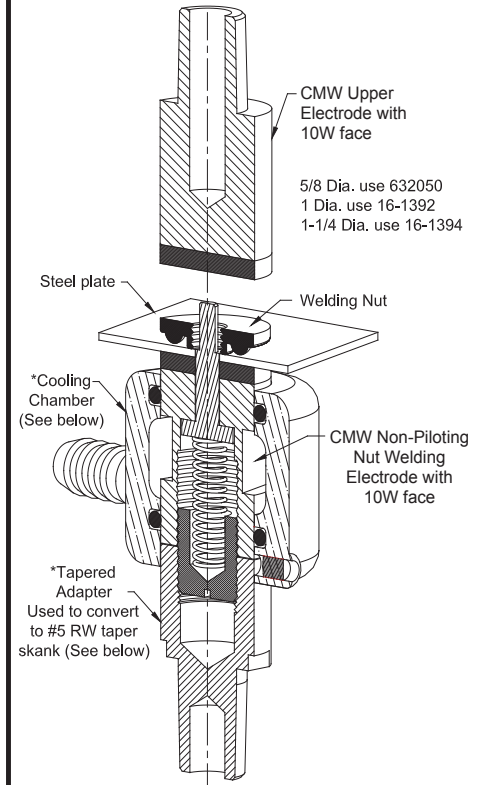

*For additional information on cooling chamber and tapered adapter see page 27

Electrode assemblies 18-3785-XX and 18-3786-XX may be used with 5/8-18 threaded holders 18-169, 18-170, 18-171

ELECTRODE COOLING CHAMBERS & TAPERED ADAPTERS



Phone: 800-521-3722

Fax: 864-877-2212

Email: cmw@cmwinc.com

FEATURES AND SPECIFICATIONS

- Cooling Chamber recommended for additional cooling capacity on internally cooled applications
- Cooling Chamber is designed to provide supplementary cooling in special, hard to cool applications

- Securely sealed and locked in position with allen head set screw
- Tapered Adapter converts 5/8-18 thread to 5 RW tapers
- Use with Stud/Nut welding applications

WELDING ELECTRODE ACCESSORIES

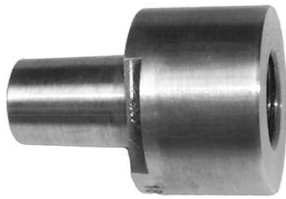

TAPERED ADAPTER			
Part No.	To Fit Dia. Electrode A	Taper	Overall Length C
18-7741	1	5 RW	1-3/4
18-7742	1-1/4	5 RW	1-3/4

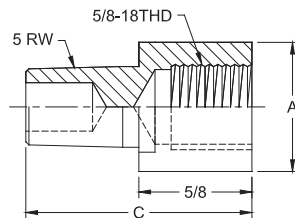

TAPERED ADAPTER CONVERSION FROM 5/8-18 THREAD TO 5 RW TAPER

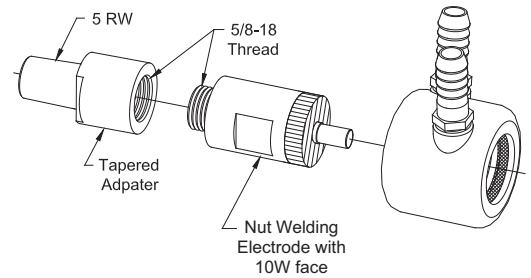

COOLING CHAMBER			
Part No.	To Fit Dia. Electrode A	O.D. B	Overall Length C
18-1340	5/8	1-1/4	1-1/2
18-1341	7/8	1-1/2	1-1/2
18-1342	1	1-3/4	1-1/2
18-1343	1-1/4	2	1-7/8

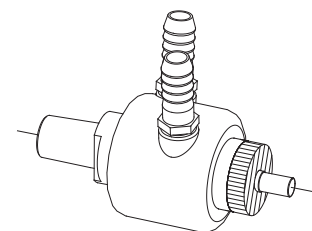
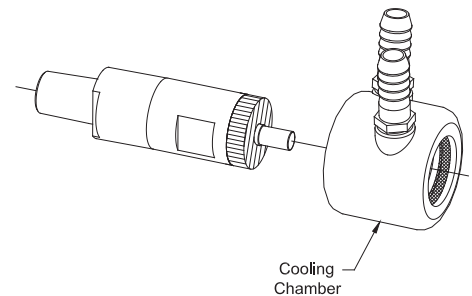
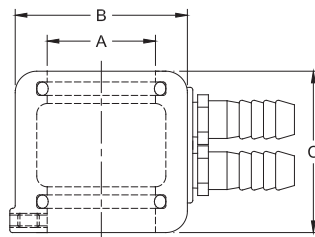

ASSEMBLED CONVERSION



STUD WELDING ELECTRODES

Phone: 800-521-3722

Fax: 864-877-2212

Email: cmw@cmwinc.com

STUD WELDING ELECTRODES



Assembled Electrode Part Number			Insulation I.D. H	Screw Thread Size		
Depth B						
.375	.750	1.125	.116 .132	#4 #5		
16-3724-1161 16-3724-1321	16-3724-1162 16-3724-1322	16-3724-1163 16-3724-1323				
.500	1.000	1.500	.140 .150 .157 .169	#6 -- -- #8		
16-3724-1401 16-3724-1501 16-3724-1571 16-3724-1691	16-3724-1402 16-3724-1502 16-3724-1572 16-3724-1692	16-3724-1403 16-3724-1503 16-3724-1573 16-3724-1693				
.750	1.500	--			.191 .220 .254	#10 #12 .250
16-3724-1911 16-3724-2201 16-3724-2541	16-3724-1912 16-3724-2202 16-3724-2542					

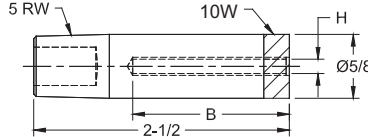

Assembled Electrode Part Number		Insulation I.D. H	Screw Thread Size
Depth B			
.750	1.500	.254	.250
16-3725-2541	16-3725-2542		
1.000	2.000	.277 .317 (8MM) .339 .365 .380	-- .312 -- -- .375
16-3725-2771 16-3725-3171 16-3725-3391 16-3725-3651 16-3725-3801	16-3725-2772 16-3725-3172 16-3725-3392 16-3725-3652 16-3725-3802		

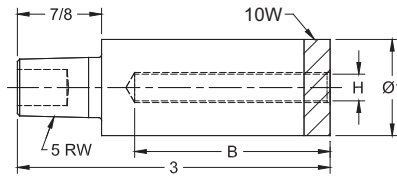

Assembled Electrode Part Number		Insulation I.D. H	Screw Thread Size		
Depth B					
1.000	2.000	.401 .427 .444 .502	-- -- .437 .500		
16-3726-4011 16-3726-4271 16-3726-4441 16-3726-5021	16-3726-4012 16-3726-4272 16-3726-4442 16-3726-5022				
1.000	2.000			.552 .630 .676 .801	-- .625 -- --
16-3726-5521 16-3726-6301 16-3726-6761 16-3726-8011	16-3726-5522 16-3726-6302 16-3726-6762 16-3726-8012				

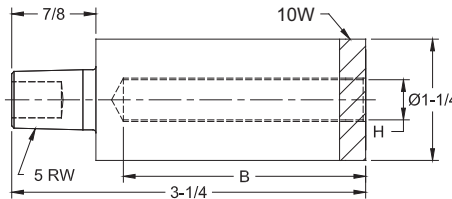

FEATURES AND SPECIFICATIONS

- 10W faced RWMA CLASS 2 material
- Insulated sleeve made of anodized aluminum
- Insulated sleeve are treated to 55 HRC both I.D. & O.D. for wear resistance
- Use with tapered electrode holders
- Use with flat faced electrodes
- Accepts external Cooling Chambers

TYPICAL SET-UP FOR STUD WELDING

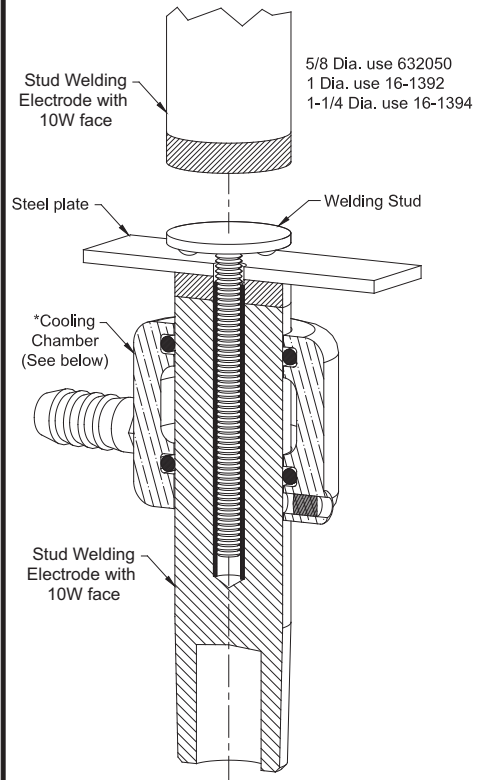

*For additional information on cooling chamber see page 27

Electrode Dia.	Cooling Chamber
5/8	18-1340
1	18-1342
1-1/4	18-1343



Phone: 800-521-3722

Fax: 864-877-2212

Email: cmw@cmwinc.com

SWIVEL HEAD BACK-UP ELECTRODES

PART No.	Taper D	Water Hole Dia. F	Face Dia. H	Type
16-2304	4 RW	9/32	7/8	Thru hole with "O" ring
16-2305	5 RW	3/8	7/8	
16-2302	4 RW	9/32	1	
16-2303	5 RW	3/8	1	
16-2300	4 RW	9/32	1-1/4	
16-2301	5 RW	3/8	1-1/4	
16-2306	5 RW	3/8	1-1/2	

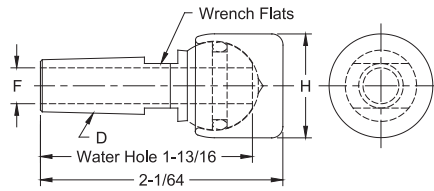

PART No.	Taper D	Water Hole Dia. F	Face Dia. H	Type
16-2314	4 RW	9/32	7/8	Blind hole
16-2315	5 RW	3/8	7/8	
16-2312	4 RW	9/32	1	
16-2313	5 RW	3/8	1	
16-2310	4 RW	9/32	1-1/4	
16-2311	5 RW	3/8	1-1/4	
16-2316	5 RW	3/8	1-1/2	

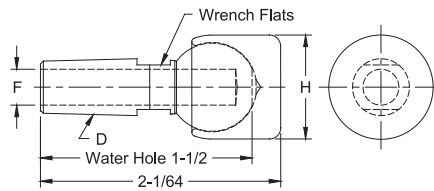

PART No.	Taper D	Water Hole Dia. F	Face Dia. H	Type
16-23129	4 RW	9/32	1	Blind hole with spring and ball
16-23139	5 RW	3/8	1	
16-23109	4 RW	9/32	1-1/4	
16-23119	5 RW	3/8	1-1/4	
16-23169	4 RW	9/32	1-1/2	
16-23179	5 RW	3/8	1-1/2	

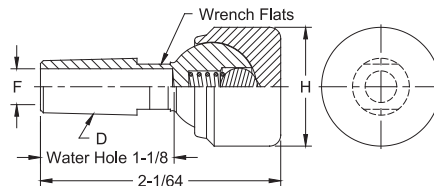

Standard material: Shank - RWMA CLASS 2
Cap - RWMA CLASS 2

Optional material available on special order:
Cap-Class 3 and 10W facing



LARGE DIAMETER FLAT FACED BACK-UP ELECTRODES

PART No.	Weld Face Material	O.A.L. C	Taper D	Water Hole		Weld Face Dia. H
				Dia. F	Depth G	
16-3012	CLASS 2	1-1/4	4 RW	9/32	7/8	3/4
16-3010						1
16-3030						1-1/4

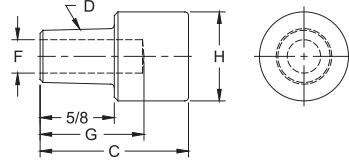

PART No.	Weld Face Material	O.A.L. C	Taper D	Water Hole		Weld Face Dia. H
				Dia. F	Depth G	
16-3021	CLASS 2	1-1/2	5 RW	3/8	1-1/8	7/8
16-3020						1
16-3040						1-1/4
16-3050						1-1/2

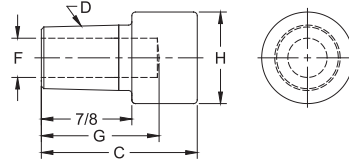

PART No.	Weld Face Material	O.A.L. C	Taper D	Water Hole		Weld Face Dia. H
				Dia. F	Depth G	
16-1392	10W	2	5 RW	3/8	1-1/2	1
16-1393						3
16-1394						2
16-1395						3-1/4

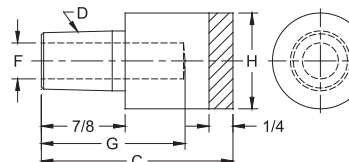

SQUARE & RECTANGULAR FACED BACK-UP ELECTRODES

PART No.	Weld Face Material	O.A.L. C	Taper D	Shank Length E	Water Hole Dia. F	Weld Face Lgth. A	Weld Face Width B
						16-382158	1-1/2
16-3111	CLASS 2 Casting	1-5/8	4 RW	7/8	9/32	2	5/8
16-382160						1-1/2	1/2
16-3121						2	5/8

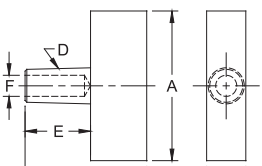

PART No.	Weld Face Material	O.A.L. C	Taper D	Shank Length E	Water Hole Dia. F	Weld Face Lgth. A	Weld Face Width B
						16-3110	1/2
16-3120	Cold Formed	1-3/4	5 RW	7/8	3/8	5/8	5/8
16-384110	Formed	1-5/8	5 RW	7/8	3/8	15/16	1/2

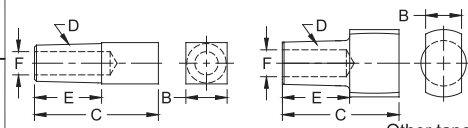

Other tapers and alloys available to special order



THREADED ELECTRODES

Phone: 800-521-3722

Fax: 864-877-2212

Email: cmw@cmwinc.com

THREADED ELECTRODES

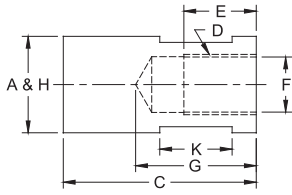

FEMALE FLAT

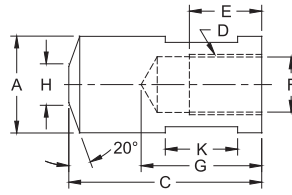

FEMALE TRUNCATED

CLASS 2 FEMALE THREADED ELECTRODES

CLASS 2 PART No.	Type	O.A.L. C	Thread D	Major Dia. A	Thread Depth E	Water Hole Depth G	Water Hole Dia. F	Over Wrench Flats	Wrench Flat Length K	Welding Face Dia. H
336508	Female Flat	2	5/8-18	1	3/4	1-1/4	37/64	7/8	3/4	1
336510				1-1/4				3/4	1-1/4	
336512				1-1/2				7/8	1-1/2	
326508	Female Truncat.	2	5/8-18	1	3/4	1-1/4	37/64	7/8	3/4	3/8
326510				1-1/4				3/4	1/2	
326512				1-1/2				7/8	5/8	

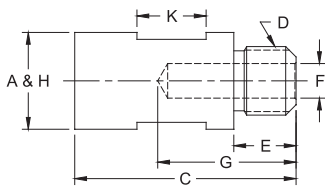

MALE FLAT

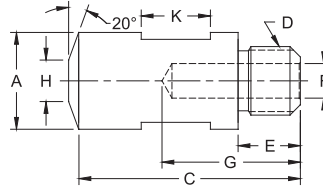

MALE TRUNCATED

CLASS 2 MALE THREADED ELECTRODES

CLASS 2 PART No.	Type	O.A.L. C	Thread D	Major Dia. A	Thread Depth E	Water Hole Depth G	Water Hole Dia. F	Over Wrench Flats	Wrench Flat Length K	Welding Face Dia. H
330507	Male Flat	2	5/8-18	7/8	9/16	1-1/4	5/16	3/4	5/8	7/8
330508				1	9/16		5/16	7/8	5/8	1
335506				3/4	15/32		5/16	1/2	3/4	
335507				7/8	15/32		3/4	7/8		
335508	Male Truncat.	2	5/8-11	3/4	5/8	1-1/4	3/8	7/8	7/8	1
335510				1-1/4	5/8		3/8	1	3/4	1-1/4
335512				1-1/2	3/4		1/2	1-1/4	7/8	1-1/2
325506	Male Truncat.	2	5/8-11	3/4	15/32	1-1/4	5/16	5/8	1/2	1/4
325507				7/8	15/32		5/16	3/4	5/8	5/16
325508				1	5/8		3/8	7/8	3/8	3/8
325510				1-1/4	5/8		3/8	3/4	1/2	

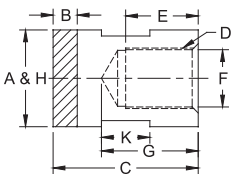

10W FACED FEMALE FLAT

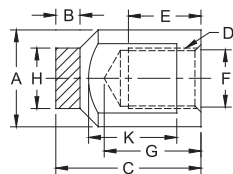

10W FACED FEMALE CENTERED

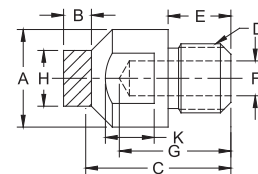

10W FACED MALE CENTERED

10W FACED MALE & FEMALE THREADED ELECTRODES

10W PART No.	Type	O.A.L. C	Thread D	Major Dia. A	Thread Depth E	Water Hole Depth G	Water Hole Dia. F	Over Wrench Flats	Wrench Flat Length K	Welding Face Dia. H	10W Thickness B
636308	Female Flat	1-1/2	5/8-18	1	3/4	1	37/64	7/8	1/2	1	1/4
636310				1-1/4				1/2	1-1/4		
636312				1-1/2				7/8	1-1/2		
626308	Female Centered	1-1/2	5/8-18	1	3/4	1	37/64	7/8	13/16	5/8	1/4
626310				1-1/4				11/16	5/8		
620307	Male Centered	1-1/2	5/8-18	7/8	9/16	1	5/16	3/4	3/4	1/2	1/4
625206				3/4	15/32		7/8	5/16	3/4	1/2	3/16
625308				1	5/8		1-3/16	3/8	7/8	5/8	1/4

FEMALE FLAT



FEMALE TRUNCATED



MALE FLAT



MALE TRUNCATED



10W FACED FEMALE FLAT



10W FACED FEMALE CENTERED



10W FACED MALE CENTERED





ADAPTERS

MALE TAPER TO FEMALE TAPER ADAPTERS								
Adapter Part No.	Male Taper			Female Taper		Length Under Head M	Hex. Over Flats H	Overall Length C
	Size L	Minor Dia. J	Dia. at 1/2 K	Size D	Major Dia. A			
18-741	5 RW	.588	.613	4 RW	.463	7/8	7/8	1-3/16
18-742	7 RW	.819	.844	5 RW	.625	1-3/16	1	1-1/2
18-7414	6 RW	.706	.731	5 RW	.625	7/8	1	1-3/16
18-7415	4 RW	.438	.463	5 RW	.625	5/8	7/8	1-3/4
18-7416	5 RW	.588	.613	6 RW	.750	7/8	1	2-1/4

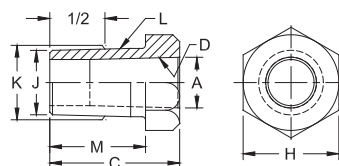

MALE PIPE THREAD TO FEMALE TAPER ADAPTERS						
Adapter Part No.	Male Thd. Size L	Female Taper		Length Under Head M	Hex. Over Flats H	Overall Length C
		Size D	Major Dia. A			
18-746-07	1/2-14 pipe	4 RW	.463	5/8	1	7/8
18-747-07	1/2-14 pipe	5 RW	.625	5/8	1	7/8
18-7465-07	1/2-14 pipe	5 RW Male Cap	.414	9/16	7/8	7/8
18-748-06	5/8-14 pipe	4 RW	.463	9/16	1	3/4
18-749-06	5/8-14 pipe	5 RW	.625	9/16	1	3/4
18-756-09	3/4-14 pipe	4 RW	.463	7/8	1-1/4	1-1/8
18-757-09	3/4-14 pipe	5 RW	.625	7/8	1-1/4	1-1/8
18-7576-09	3/4-14 pipe	6 RW	.750	7/8	1-1/4	1-1/8

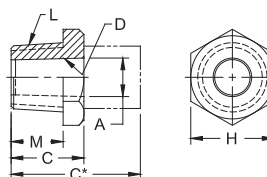

*Adapters of longer lengths available in 1/8" increments upon request

MALE THREAD TO FEMALE TAPER ADAPTERS							
Adapter Part No.	Male Thd. Size L	Female Taper		Length Under Head M	Hex or Dia. Over. Flats H	Overall Length C	Sealing Ring Part No.
		Size D	Major Dia. A				
18-750	5/8-18	4 RW	.463	9/16	7/8 Hex	13/16	18-10060-11
18-751	5/8-18	5 RW	.625	9/16	1 Hex	1-11/16	18-10060-11
18-755*	3/4-10	5 RW	.625	9/16	1 Dia.	1-9/16	18-10060-12
18-770	7/8-14	4 RW	.463	5/8	1 Hex	13/16	18-76460
18-771	7/8-14	5 RW	.625	5/8	1 Hex	13/16	18-76460
18-7743	1-14	5/8-18 Thd.	-	5/8	1-1/4 Hex	1	18-10060-17
18-785	1-14	4 RW	.463	9/16	1-1/4 Hex	13/16	18-10060-17
18-786	1-14	5 RW	.625	9/16	1-1/4 Hex	13/16	18-10060-17
18-7863	1-14	6 RW	.750	3/4	1-1/4 Hex	1-3/4	18-10060-17
18-787	1-14	7 RW	.875	3/4	1-1/4 Hex	2-1/8	18-10060-17
18-7875	1-14	5 RW	.625	9/16	1-1/4 Dia.	11/16	18-10060-17
18-7876	1-14	6 RW	.750	5/8	1-1/4 Dia.	7/8	18-10060-17

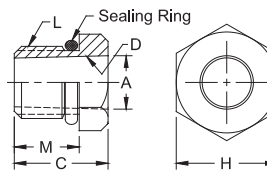

*This part has 3/4" wrench flats

FEMALE THREAD TO FEMALE TAPER ADAPTERS						
Adapter Part No.	Female Thd. Size L	Female Taper		Outside Dia. B	Over Wrench Flats H	Overall Length C
		Size D	Major Dia. A			
18-753	5/8-18	4 RW	.475	1	3/4	1-5/8
18-754	5/8-18	5 RW	.625	1	3/4	1-5/8
18-7591	3/4-10	4 RW	.463	1-1/4 Hex.	1-1/4	1-3/4
18-7592	3/4-10	5 RW	.625	1-1/4 Hex.	1-1/4	1-3/4

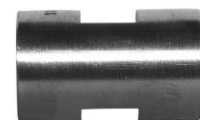
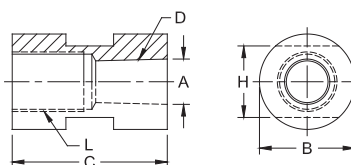

See page 6 for Metric Conversions
See page 7 for Taper Dimensions
See page 34 for ejector type adapters

CONVERSION FROM 5/8-18 THREAD INTO 4, 5, 6, RW TAPER

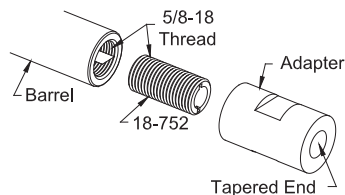
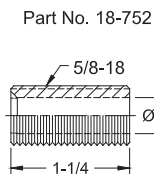

Threaded adapter used with tapered adapter to convert holder to use tapered electrodes.

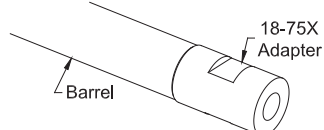

CONVERSION FROM THREADED ADAPTER INTO 4, 5, 6, RW TAPER

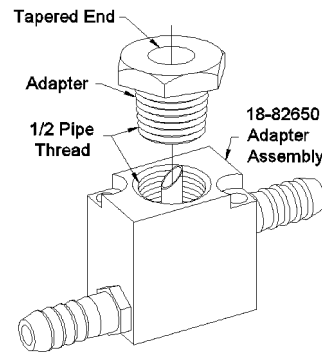
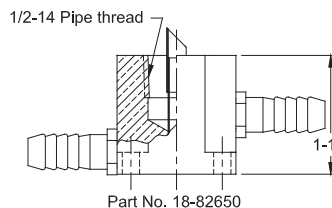
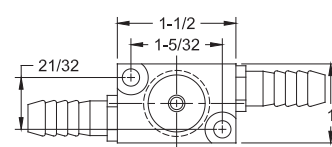

100 SERIES (NON-EJECTOR) WATER COOLED ELECTRODE HOLDER



Phone: 800-521-3722

Fax: 864-877-2212

Email: cmw@cmwinc.com

100 SERIES (NON-EJECTOR) WATER COOLED ELECTRODE HOLDER

100 SERIES TAPERED HOLDER					
Part No. Holder Assy.	Major Taper Dia. A	Barrel Dia. B	Barrel Length C	RW Taper D	Engagement With Std. Elect. E
18-101	.463	3/4	3	4 RW	1/2
18-102		7/8			
18-103		1			
18-104		1-1/4			
18-106	.625	1	8	5 RW	3/4
18-107		1-1/4			
18-108		1-1/2			
18-111	.463	3/4	8	4 RW	1/2
18-112		7/8			
18-113		1			
18-114		1-1/4			
18-116	.625	1	8	5 RW	3/4
18-117		1-1/4			
18-118		1-1/2			
18-119	.875	1-1/4	8	7 RW	1-1/8
18-120		1-1/2			
18-131	.463	3/4	12	4 RW	1/2
18-132		7/8			
18-133		1			
18-134		1-1/4			
18-136	.625	1	12	5 RW	3/4
18-137		1-1/4			
18-138		1-1/2			

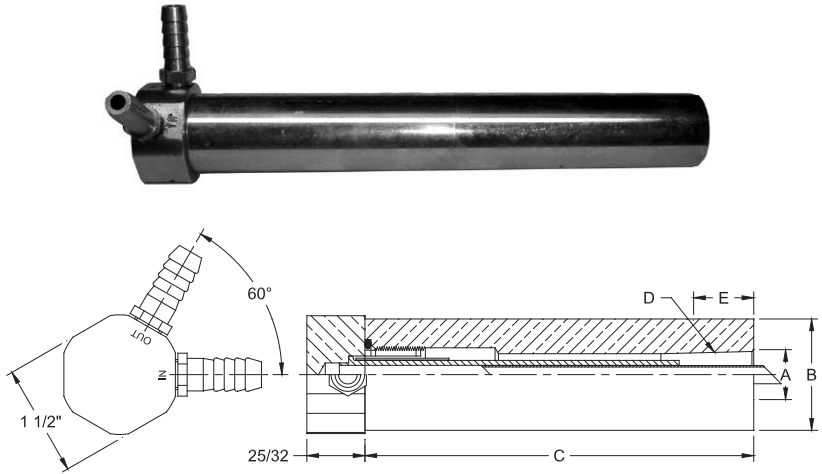

100 SERIES THREADED HOLDER				
Part No. Holder Assy.	Barrel Dia. B	Barrel Length C	Thread Size D	Engagement With Std. Electrode E
18-169	1	8	5/8-18	9/16
18-170	1-1/4			
18-171	1-1/2			
18-172	1	8	7/8-14	9/16
18-173	1-1/4			
18-174	1-1/2			
18-175	1-1/4	8	1-14	3/4
18-176	1-1/2			

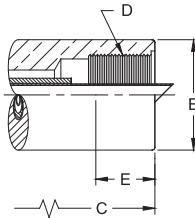

See available adapters in table below.

ADAPTERS USED WITH THREADED HOLDERS

100 SERIES THREADED HOLDER ADAPTERS					
Holder Assembly No.	Adapter Part No.	Page No.	Attachment Description		
18-169 18-170 18-171	Use with	18-750	31	4 RW Female	
		18-751	31	5 RW Female	
		18-752	31	5/8-18 M. Thread	
		18-811	50	#1 Size Nu-Twist®	
18-172 18-173 18-174	Use with	18-770	31	4 RW Female	May also be used with universal Adapters having 7/8-14 Male thread See page 46
		18-771	31	5 RW Female	
18-175 18-176	Use with	18-785	31	4 RW Female	May also be used with universal Adapters having 1-14 Male thread See page 46
		18-786	31	5 RW Female	
		18-7863	31	6 RW Female	
		18-787	31	7 RW Female	
		18-812	50	#2 Size Nu-Twist®	

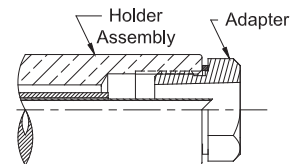
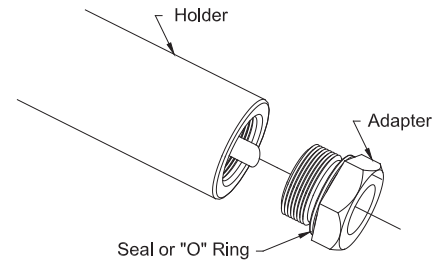

100 SERIES (NON-EJECTOR) REPLACEMENT PARTS



Phone: 800-521-3722

Fax: 864-877-2212

Email: cmw@cmwinc.com

100 SERIES (NON-EJECTOR) WATER COOLED ELECTRODE HOLDER

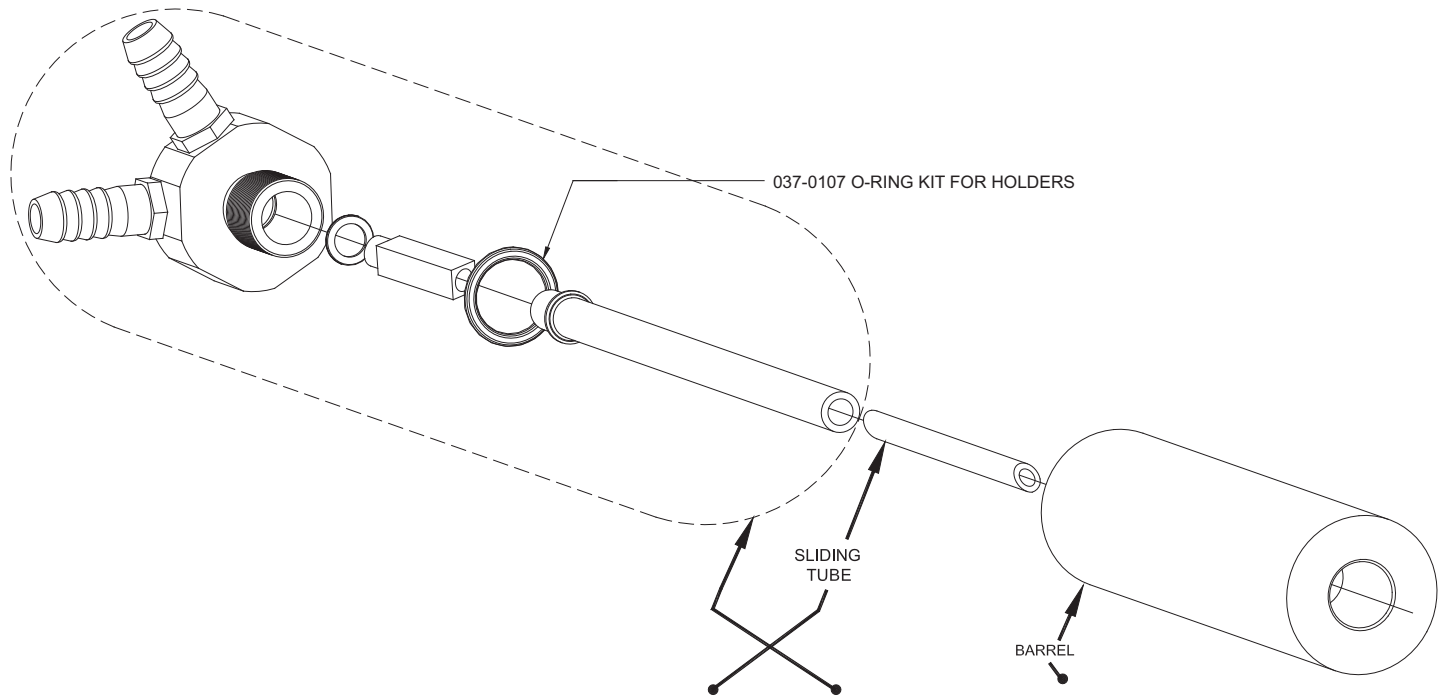

Part No. Holder Assy.	Thread Or Taper	Barrel Length	Sliding Tube	Water Conn. HD. Sub-Assy.	Barrel Diameter	Barrel
18-101 18-102 18-103 18-104	4 RW	3	18-10046-3	18-10093-5 18-10093-5 18-10091-3 18-10091-3	3/4 7/8 1 1-1/4	18-11110-3 18-11210-3 18-11310-3 18-11410-3
18-106 18-107 18-108	5 RW	3	18-10047-3	18-10092-3	1 1-1/4 1-1/2	18-11610-3 18-11710-3 18-11810-3
18-111 18-112 18-113 18-114	4 RW	8	18-10046-8	18-10093-8 18-10093-8 18-10091-8 18-10091-8	3/4 7/8 1 1-1/4	18-11110-8 18-11210-8 18-11310-8 18-11410-8
18-116 18-117 18-118	5 RW	8	18-10047-8	18-10092-8	1 1-1/4 1-1/2	18-11610-8 18-11710-8 18-11810-8
18-119 18-120	7 RW	8	18-10047-8	18-10092-8	1-1/4 1-1/2	18-11910-8 18-12010-8
18-131 18-132 18-133 18-134	4 RW	12	18-10046-8	18-10093-12 18-10093-12 18-10091-12 18-10091-12	3/4 7/8 1 1-1/4	18-11110-12 18-11210-12 18-11310-12 18-11410-12
18-136 18-137 18-138	5 RW	12	18-10047-8	18-10092-12	1 1-1/4 1-1/2	18-11610-12 18-11710-12 18-11810-12
18-169 18-170 18-171	5/8-18	8	18-10047-8	18-10092-8	1 1-1/4 1-1/2	18-16910-8 18-17010-8 18-17110-8
18-172 18-173 18-174	7/8-14	8	18-10047-8	18-10092-8	1 1-1/4 1-1/2	18-17210-8 18-17310-8 18-17410-8
18-175 18-176	1-14	8	18-10047-8	18-10092-8	1-1/4 1-1/2	18-17510-8 18-17610-8

200 SERIES (EJECTOR) WATER COOLED ELECTRODE HOLDER



Phone: 800-521-3722

Fax: 864-877-2212

Email: cmw@cmwinc.com

200 SERIES (EJECTOR) WATER COOLED ELECTRODE HOLDER

200 SERIES TAPERED HOLDER										
Part No. Holder Assy.	Major Taper Dia. A	Barrel Dia. B	Barrel Length C	RW Taper D	Engagement With Std. Elect. E					
18-201 18-202 18-203 18-204	.463	3/4 7/8 1 1-1/4	3	4 RW	1/2					
18-206 18-207 18-208	.625	1 1-1/4 1-1/2				8	5 RW	3/4		
18-211 18-212 18-213 18-214	.463	3/4 7/8 1 1-1/4							4 RW	1/2
18-216 18-217 18-218	.625	1 1-1/4 1-1/2								
18-219* 18-220*	.875	1-1/4 1-1/2	7 RW	1-1/8						
18-231 18-232 18-233 18-234	.463	3/4 7/8 1 1-1/4	12	4 RW	1/2					
18-236 18-237 18-238	.625	1 1-1/4 1-1/2				5 RW	3/4			
18-236-18 18-237-18 18-238-18	.625	1 1-1/4 1-1/2						5 RW	3/4	

*Must use knockout adapter 18-20033

200 SERIES THREADED HOLDER				
Part No. Holder Assy.	Barrel Dia. B	Barrel Length C	Thread Size D	Engagement With Std. Elect. E
18-272 18-273 18-274	1 1-1/4 1-1/2	8	7/8-14	9/16
18-275 18-276	1-1/4 1-1/2		1-14	3/4

200 Series Threaded Holder can use Male Threaded to Female Taper Universal Adapters on page 46.

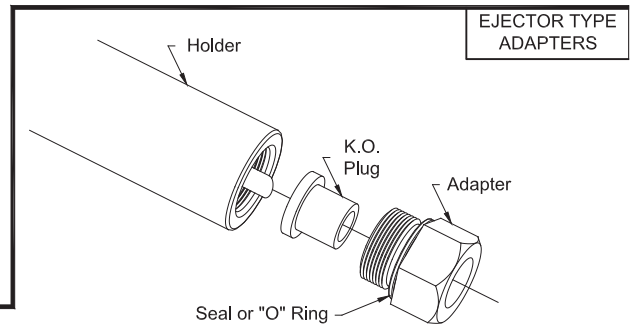
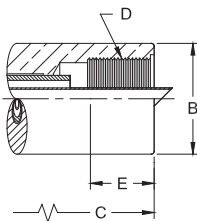
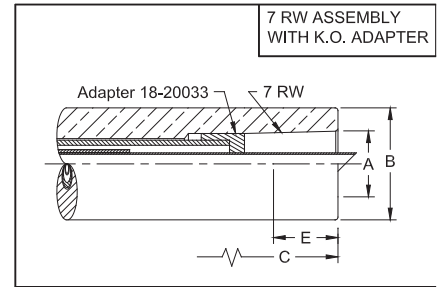
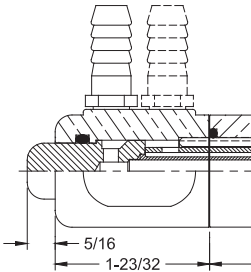
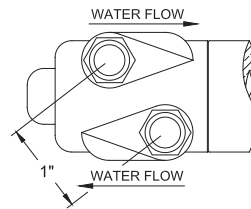

EJECTOR TYPE ADAPTERS

EJECTOR TYPE ADAPTERS 7/8-14 THREAD								
Adapter Part No.	Male Thd. Size L	Female Taper Size Major Dia. A		Length Under Hd. M	Hex. Over Flats H	Overall Length C	Sealing Ring Part No.	K.O. Plug Part No.
	Size D							
18-7702	7/8-14	4 RW	.463	5/8	1	13/16	18-76460	18-78501
18-7712	7/8-14	5 RW	.625	1/2	1	1-1/16	18-76460	18-7712-3

Use with Threaded Ejector Holder to make Replaceable Taper Holders

Part No.	Female Thd. Size	Barrel Dia.
18-272	7/8-14	1
18-273	7/8-14	1-1/4
18-274	7/8-14	1-1/2

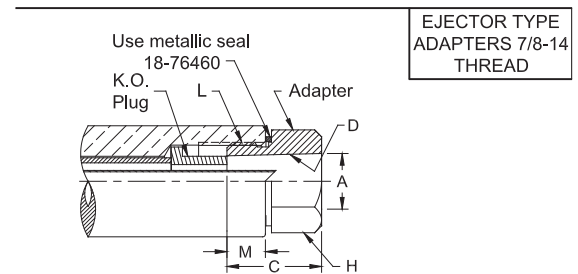

EJECTOR TYPE ADAPTERS 1-14 THREAD								
Adapter Part No.	Male Thd. Size L	Female Taper Size Major Dia. A		Length Under Hd. M	Hex. Over Flats H	Overall Length C	Sealing Ring Part No.	K.O. Plug Part No.
	Size D							
18-7852 18-7862	1-14 1-14	4 RW 5 RW	.463 .625	9/16 7/16	1-1/4 1-1/4	13/16 1-1/16	18-10060-17	18-78501 18-7712-3
18-7864 18-7872	1-14 1-14	6 RW 7 RW	.750 .875	3/4 3/4	1-1/4 1-1/4	1-3/4 2-1/8	18-10060-17	18-78650 18-78701

Use with Threaded Ejector Holder to make Replaceable Taper Holders

Part No.	Female Thd. Size	Barrel Dia.
18-275	1-14	1-1/4
18-276	1-14	1-1/2

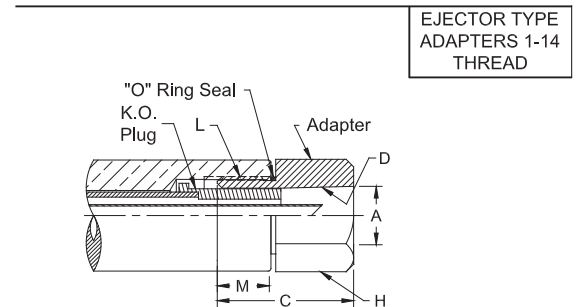

200 SERIES (EJECTOR) REPLACEMENT PARTS



Phone: 800-521-3722

Fax: 864-877-2212

Email: cmw@cmwinc.com

200 SERIES (EJECTOR) WATER COOLED ELECTRODE HOLDER

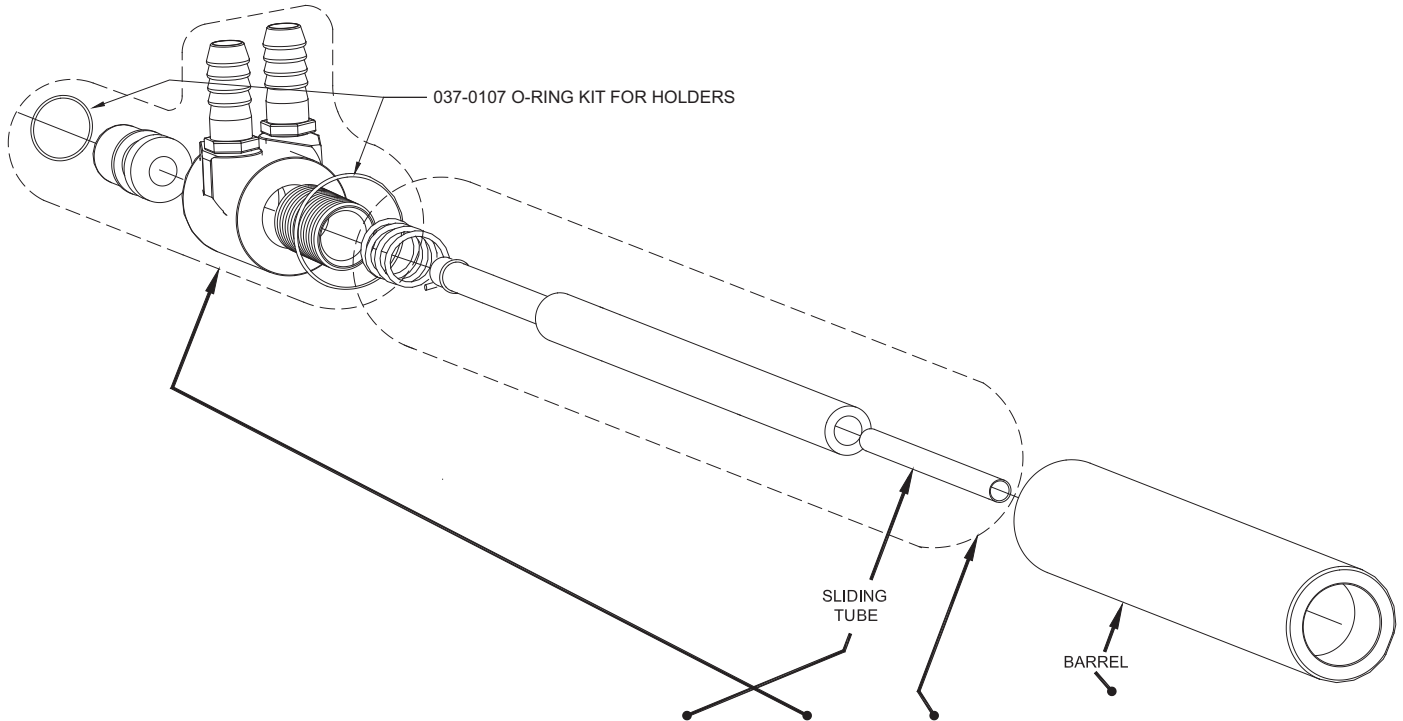

Part No. Holder Assy.	Thread Or Taper	Barrel Length	Sliding Tube	Water Conn. HD. Sub-Assy.	K.O. Tube Sub-Assy	Barrel Diameter	Barrel
18-201 18-202 18-203 18-204	4 RW	3	18-10046-3	18-20093 18-20093 18-20091 18-20091	18-20095-3	3/4 7/8 1 1-1/4	18-11110-3 18-11210-3 18-11310-3 18-11410-3
18-206 18-207 18-208	5 RW	3	18-10047-3	18-20092	18-20096-3	1 1-1/4 1-1/2	18-11610-3 18-11710-3 18-11810-3
18-211 18-212 18-213 18-214	4 RW	8	18-10046-8	18-20093 18-20093 18-20091 18-20091	18-20095-8	3/4 7/8 1 1-1/4	18-11110-8 18-11210-8 18-11310-8 18-11410-8
18-216 18-217 18-218	5 RW	8	18-10047-8	18-20092	18-20096-8	1 1-1/4 1-1/2	18-11610-8 18-11710-8 18-11810-8
18-219* 18-220*	7 RW	8	18-10047-8	18-20092	18-20096-58	1-1/4 1-1/2	18-11910-8 18-12010-8
18-231 18-232 18-233 18-234	4 RW	12	18-10046-8	18-20093 18-20093 18-20091 18-20091	18-20095-12	3/4 7/8 1 1-1/4	18-11110-12 18-11210-12 18-11310-12 18-11410-12
18-236 18-237 18-238	5 RW	12	18-10047-8	18-20092	18-20096-12	1 1-1/4 1-1/2	18-11610-12 18-11710-12 18-11810-12
18-236-18 18-237-18 18-238-18	5 RW	18	18-10047-29	18-20092	18-20096-18	1 1-1/4 1-1/2	18-11610-18 18-11710-18 18-11810-18
18-272 18-273 18-274	7/8-14	8	18-10047-8	18-20092	18-20096-8	1 1-1/4 1-1/2	18-17210-8 18-17310-8 18-17410-8
18-275 18-276	1-14	8	18-10047-8	18-20092	18-20096-8	1-1/4 1-1/2	18-17510-8 18-17610-8

*Must use knockout adapter 18-20033

CMW 300 SERIES PREMIUM (EJECTOR) WATER COOLED ELECTRODE HOLDERS

Phone: 800-521-3722

Fax: 864-877-2212

Email: cmw@cmwinc.com

300 SERIES PREMIUM (EJECTOR) WATER COOLED ELECTRODE HOLDER

CMW Premium holder barrels are made from high strength RWMA CLASS 2 material, centerless ground within .002" tolerance on diameter and nickel plated to resist wear and assure uniform contact resistance of a low magnitude.



300 SERIES TAPERED HOLDER					
Part No. Holder Assy.	Major Taper Dia. A	Barrel Dia. B	Barrel Length C	RW Taper D	Engagement With Std. Elect. E
18-317 18-318	.625	1-1/4 1-1/2	8	5 RW	3/4
18-319* 18-320*	.875	1-1/4 1-1/2		7 RW	1-1/8
18-337 18-338	.625	1-1/4 1-1/2	12	5 RW	3/4
18-339* 18-340*	.875	1-1/4 1-1/2		7 RW	1-1/8

*Must use knockout adapter 18-20033

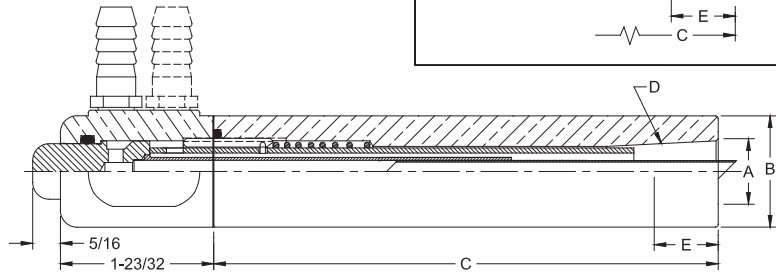
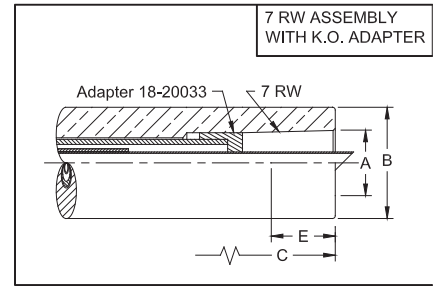
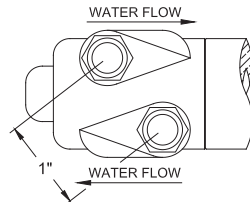

300 SERIES THREADED HOLDER				
Part No. Holder Assy.	Barrel Dia. B	Barrel Length C	Thread Size D	Engagement With Std. Elect. E
18-372 18-373	1 1-1/4	8	7/8-14	9/16
18-375 18-376	1-1/4 1-1/2		1-14	3/4

300 Series Threaded Holder can use Male Threaded to Female Taper Universal Adapters on page 46.

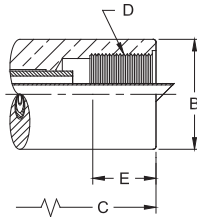

Note: These threaded holder barrels are the same as on 600 series holders on page 44.

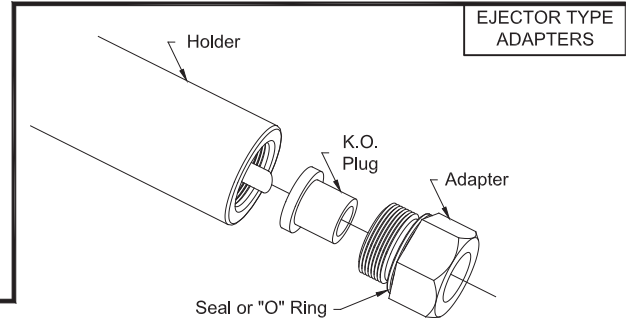

EJECTOR TYPE ADAPTERS

EJECTOR TYPE ADAPTERS 7/8-14 THREAD								
Adapter Part No.	Male Thd. Size L	Female Taper		Length Under Hd. M	Hex. Over Flats H	Overall Length C	Sealing Ring Part No.	K.O. Plug Part No.
		Size D	Major Dia.					
18-7702 18-7712	7/8-14 7/8-14	4 RW 5 RW	.463 .625	5/8 1/2	1 1	13/16 1-1/16	18-76460 18-76460	18-78501 18-7712-3

Use with Threaded Ejector Holder to make Replaceable Taper Holders

Part No.	Female Thd. Size	Barrel Dia.
18-372 18-373	7/8-14 7/8-14	1 1-1/4

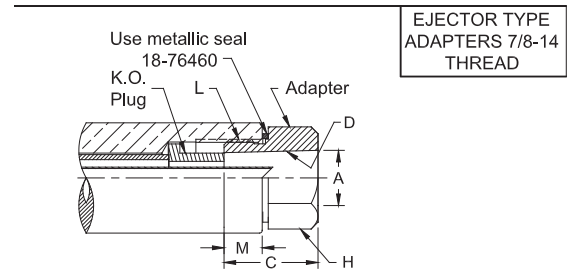

EJECTOR TYPE ADAPTERS 1-14 THREAD								
Adapter Part No.	Male Thd. Size L	Female Taper		Length Under Hd. M	Hex. Over Flats H	Overall Length C	Sealing Ring Part No.	K.O. Plug Part No.
		Size D	Major Dia.					
18-7852 18-7862	1-14 1-14	4 RW 5 RW	.463 .625	9/16 7/16	1-1/4 1-1/4	13/16 1-1/16	18-10060-17 18-10060-17	18-78501 18-7712-3
18-7864 18-7872	1-14 1-14	6 RW 7 RW	.750 .875	3/4 3/4	1-1/4 1-1/4	1-3/4 2-1/8	18-10060-17 18-10060-17	18-78650 18-78701

Use with Threaded Ejector Holder to make Replaceable Taper Holders

Part No.	Female Thd. Size	Barrel Dia.
18-375 18-376	1-14 1-14	1-1/4 1-1/2

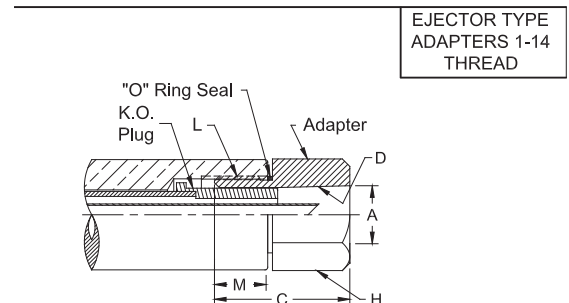

300 SERIES PREMIUM (EJECTOR) REPLACEMENT PARTS



Phone: 800-521-3722

Fax: 864-877-2212

Email: cmw@cmwinc.com

300 SERIES PREMIUM (EJECTOR) WATER COOLED ELECTRODE HOLDER

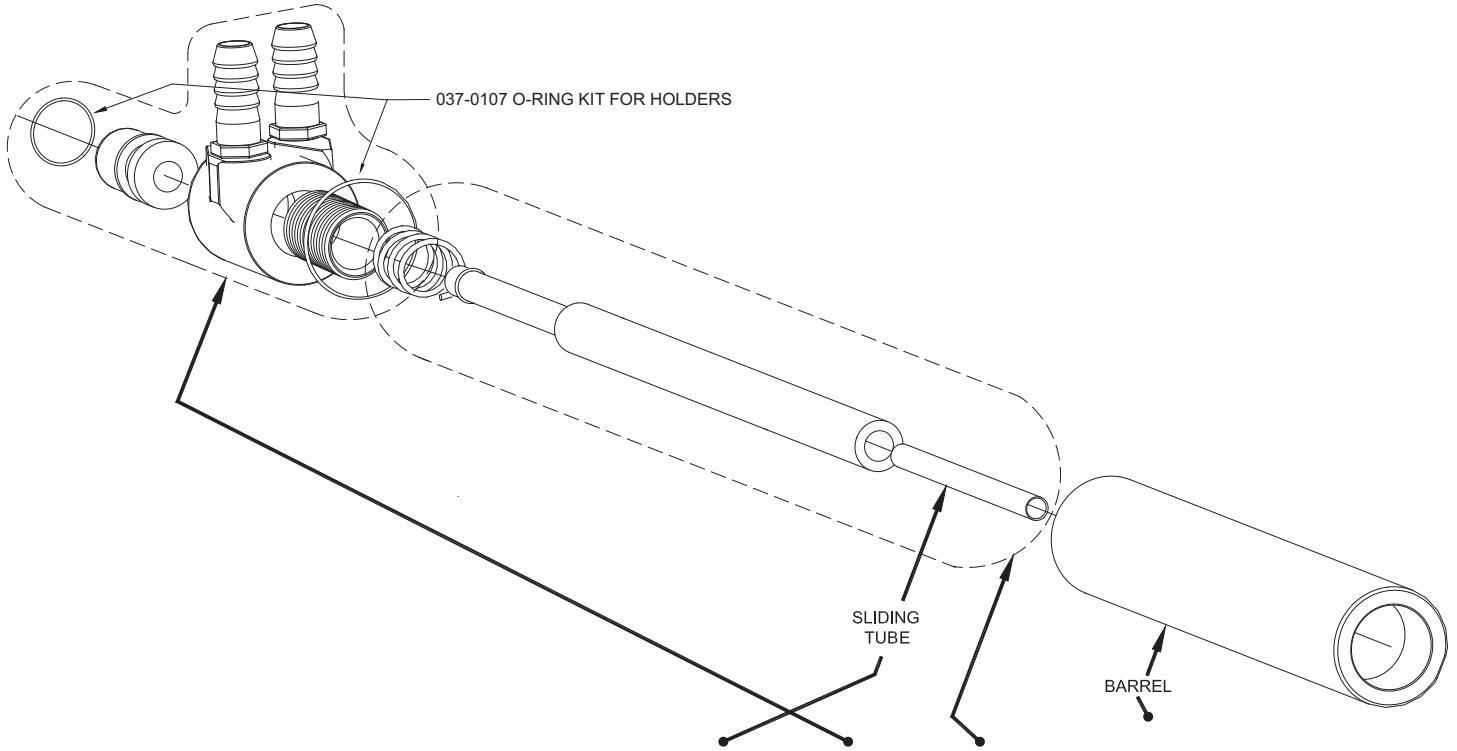

Part No. Holder Assy.	Thread Or Taper	O.A.L	Sliding Tube	Water Conn. HD. Sub-Assy.	K.O. Tube Sub-Assy	Barrel Diameter	Barrel
18-317 18-318	5 RW	8	18-10047-8	18-20092	18-20096-8	1-1/4 1-1/2	18-31710-8 18-31810-8
18-319* 18-320*	7 RW	8	18-10047-8	18-20092	18-20096-58	1-1/4 1-1/2	18-31910-8 18-32010-8
18-337 18-338	5 RW	12	18-10047-8	18-20092	18-20096-12	1-1/4 1-1/2	18-31710-12 18-31810-12
18-339* 18-340*	7 RW	12	18-10047-8	18-20092	18-20096-62	1-1/4 1-1/2	18-31910-12 18-32010-12
18-372 18-373	7/8-14	8	18-10047-8	18-20092	18-20096-8	1 1-1/4	18-37210-8 18-37310-8
18-375 18-376	1-14	8	18-10047-8	18-20092	18-20096-8	1-1/4 1-1/2	18-37510-8 18-37610-8

*Must use knockout adapter 18-20033

CMW TYPICAL SET-UP COMBINATIONS USING CMW WELDING PRODUCTS

Phone: 800-521-3722

Fax: 864-877-2212

Email: cmw@cmwinc.com

COMBINATIONS OF CMW HOLDERS, ADAPTERS AND ELECTRODES CAN PERFORM MOST RESISTANCE WELDING APPLICATIONS

Many of these combinations make possible welding operations that could have been done heretofore only by the use of "expensive and special" holders and electrodes. A few ideas of the many possible combinations are shown for your guidance.

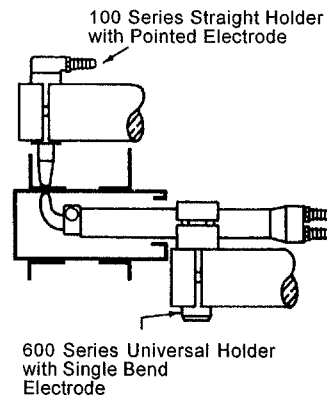
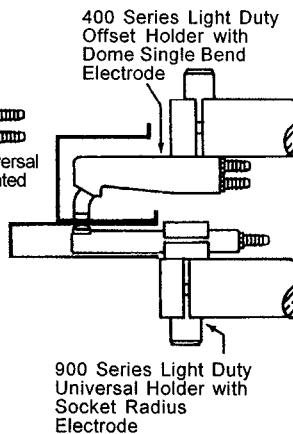
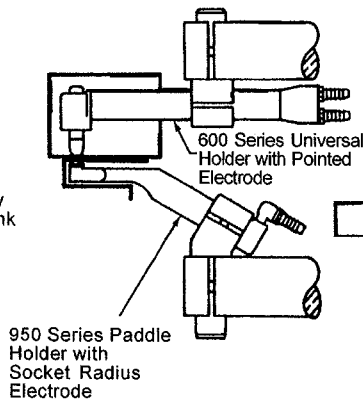
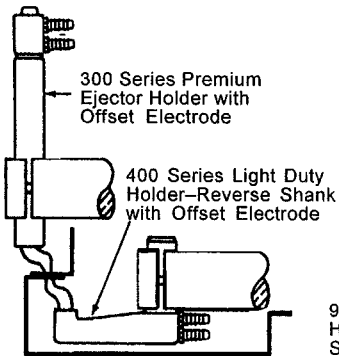
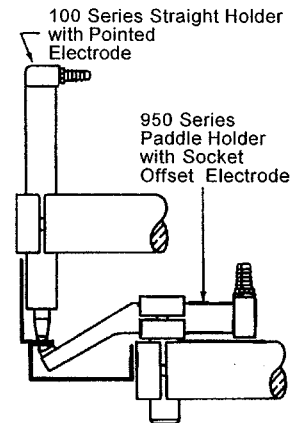
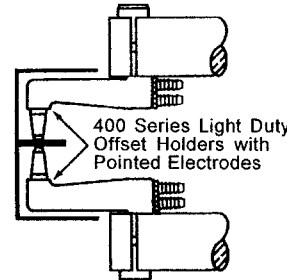
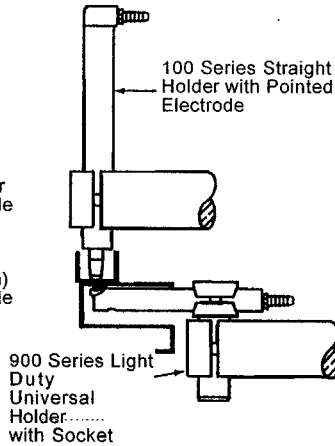
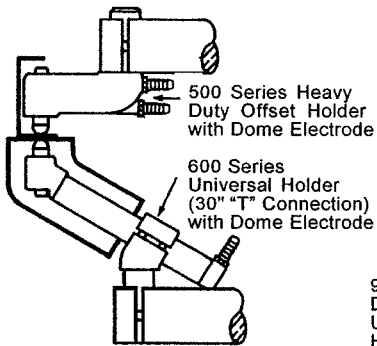
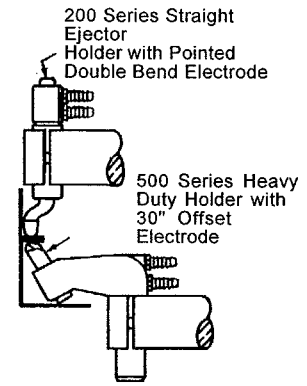
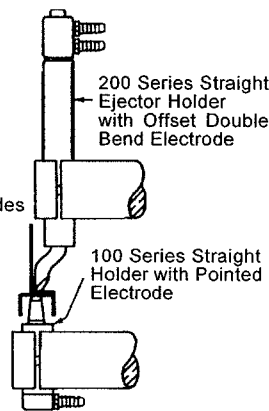
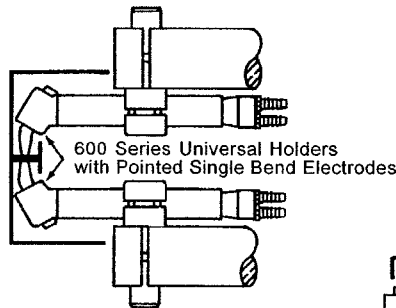
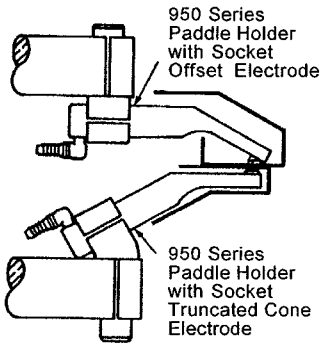
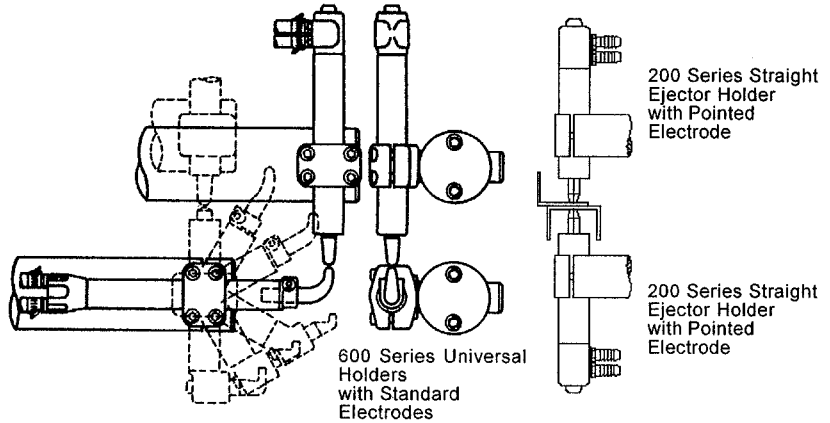

400 SERIES OFFSET (NON-EJECTOR) WATER COOLED ELECTRODE HOLDERS



Phone: 800-521-3722

Fax: 864-877-2212

Email: cmw@cmwinc.com

400 SERIES OFFSET (NON-EJECTOR) WATER COOLED ELECTRODE HOLDERS

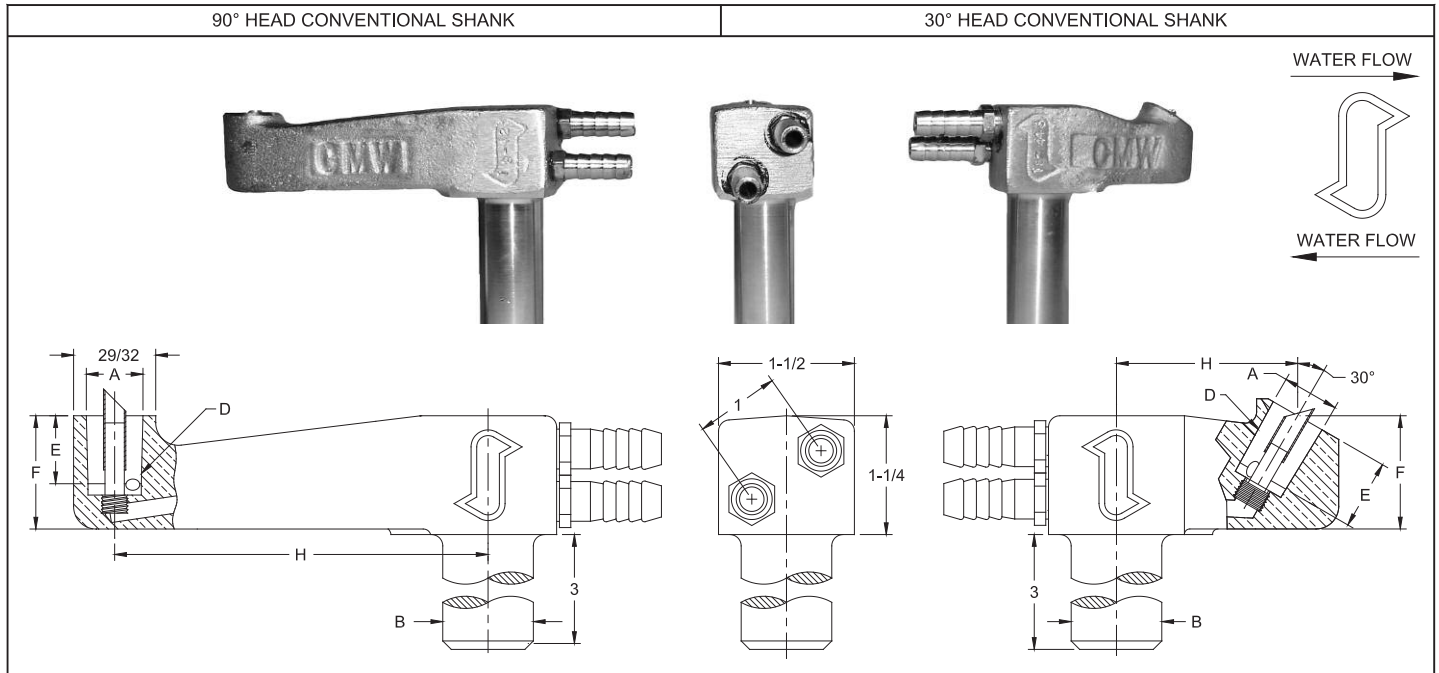

400 SERIES OFFSET HOLDER (CONVENTIONAL SHANK 90°)

Part No. Holder Assy.	Major Taper Dia. A*	Shank Dia. B*	RW Taper D	Engagement With Electrode E	Head Height F	Offset H
18-402	.463	7/8	4 RW	1/2	1-1/16	2
18-403		1				
18-404		1-1/4				
18-407	.625	7/8	5 RW	3/4	1-1/4	2
18-408		1				
18-409		1-1/4				
18-422	.463	7/8	4 RW	1/2	1-1/16	4
18-423		1				
18-424		1-1/4				
18-428	.625	1	5 RW	3/4	1-1/4	4
18-429		1-1/4				

*Other shank diameters and lengths or tapers available on special order

400 SERIES OFFSET HOLDER (CONVENTIONAL SHANK 30°)

Part No. Holder Assy.	Major Taper Dia. A*	Shank Dia. B*	RW Taper D	Engagement With Electrode E	Head Height F	Offset H
18-442	.463	7/8	4 RW	1/2	1	2
18-443		1				
18-444		1-1/4				
18-448	.625	1	5 RW	3/4	1-1/4	2
18-449		1-1/4				
18-462	.463	7/8	4 RW	1/2	1	4
18-463		1				
18-464		1-1/4				
18-468	.625	1	5 RW	3/4	1-1/4	4
18-469		1-1/4				

*Other shank diameters and lengths or tapers available on special order

400 SERIES OFFSET (NON-EJECTOR) WATER COOLED ELECTRODE HOLDERS

90° HEAD REVERSE SHANK

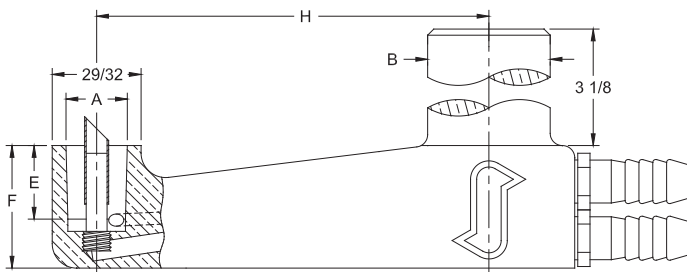

400 SERIES OFFSET HOLDER (REVERSE SHANK 90°)

Part No. Holder Assy.	Major Taper Dia. A*	Shank Dia. B*	RW Taper D	Engagement With Electrode E	Head Height F	Offset H
18-433	.463	1	4 RW	1/2	1-1/16	4
18-439	.625	1-1/4	5 RW	3/4	1-1/4	4

*Other shank diameters and lengths or tapers available on special order

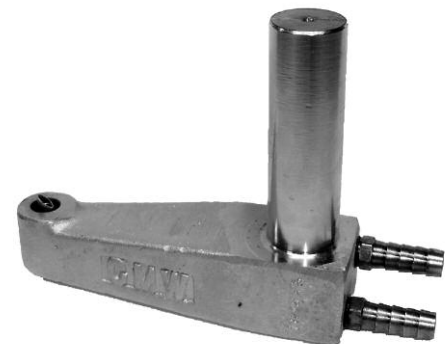

CMW 400 SERIES OFFSET (NON-EJECTOR) REPLACEMENT PARTS

Phone: 800-521-3722

Fax: 864-877-2212

Email: cmw@cmwinc.com

400 SERIES OFFSET (NON-EJECTOR) REPLACEMENT PARTS

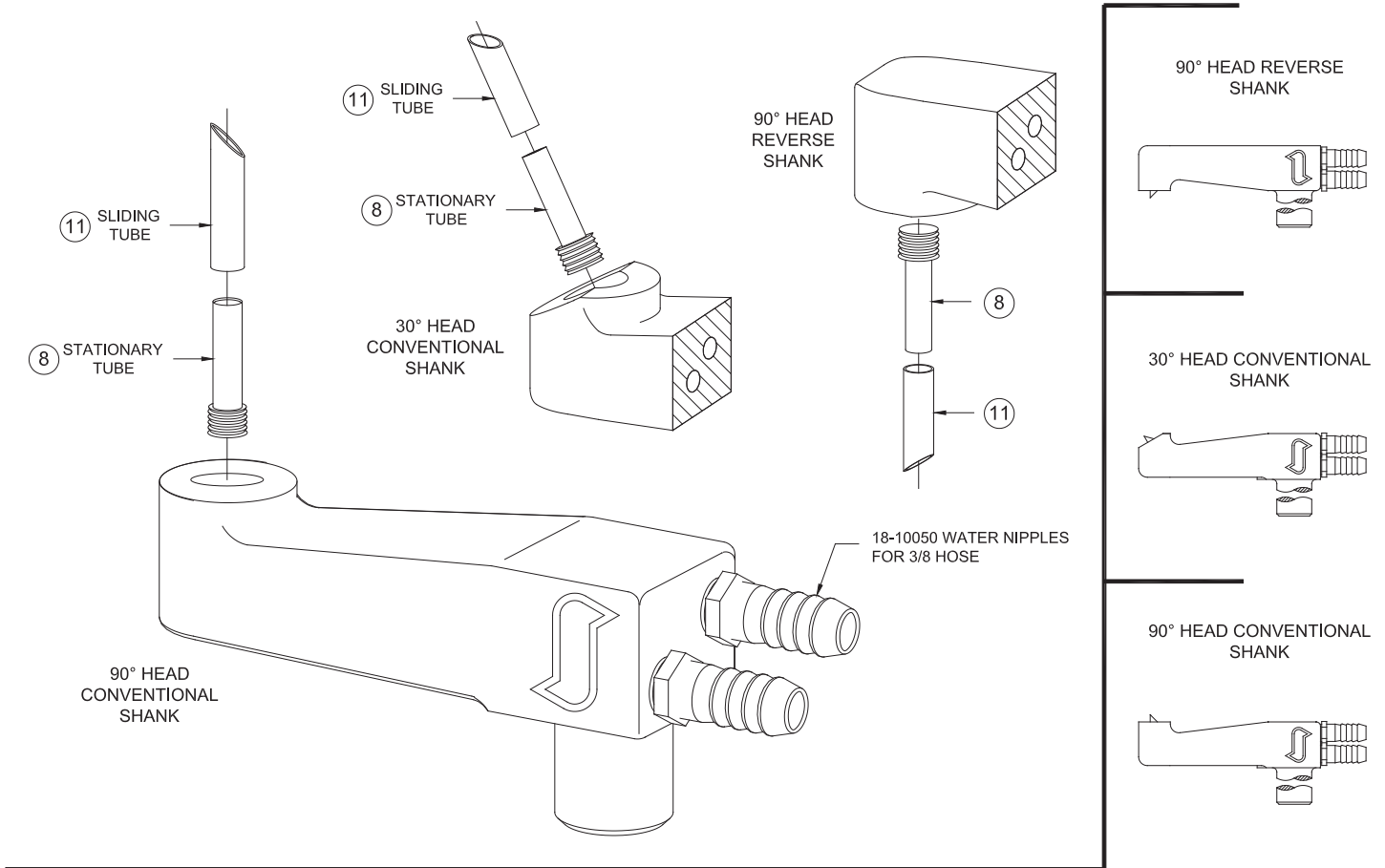

Part No. Holder Assy.	Taper	Angle Of Head	Stationary Tube 8	Sliding Tube 11	Shank Dia.
18-402	4 RW	90°	18-40041-1	18-40043-1	7/8
18-403					1
18-404					1-1/4
18-407	5 RW	90°	18-40041-1	18-40043-2	7/8
18-408					1
18-409					1-1/4
18-422	4 RW	90°	18-40041-1	18-40043-1	7/8
18-423					1
18-424					1-1/4
18-433*					1
18-428	5 RW	90°	18-40041-1	18-40043-2	1
18-429					1-1/4
18-439*					1-1/4
18-442	4 RW	30°	18-40041-1	18-40043-1	7/8
18-443					1
18-444					1-1/4
18-448	5 RW	30°	18-40041-1	18-40043-2	1
18-449					1-1/4
18-462	4 RW	30°	18-40041-1	18-40043-1	7/8
18-463					1
18-464					1-1/4
18-468	5 RW	30°	18-40041-1	18-40043-2	1
18-469					1-1/4

*Reverse shank

500 SERIES PREMIUM (EJECTOR) WATER COOLED OFFSET HOLDERS



Phone: 800-521-3722

Fax: 864-877-2212

Email: cmw@cmwinc.com

500 SERIES PREMIUM (EJECTOR) WATER COOLED OFFSET HOLDERS

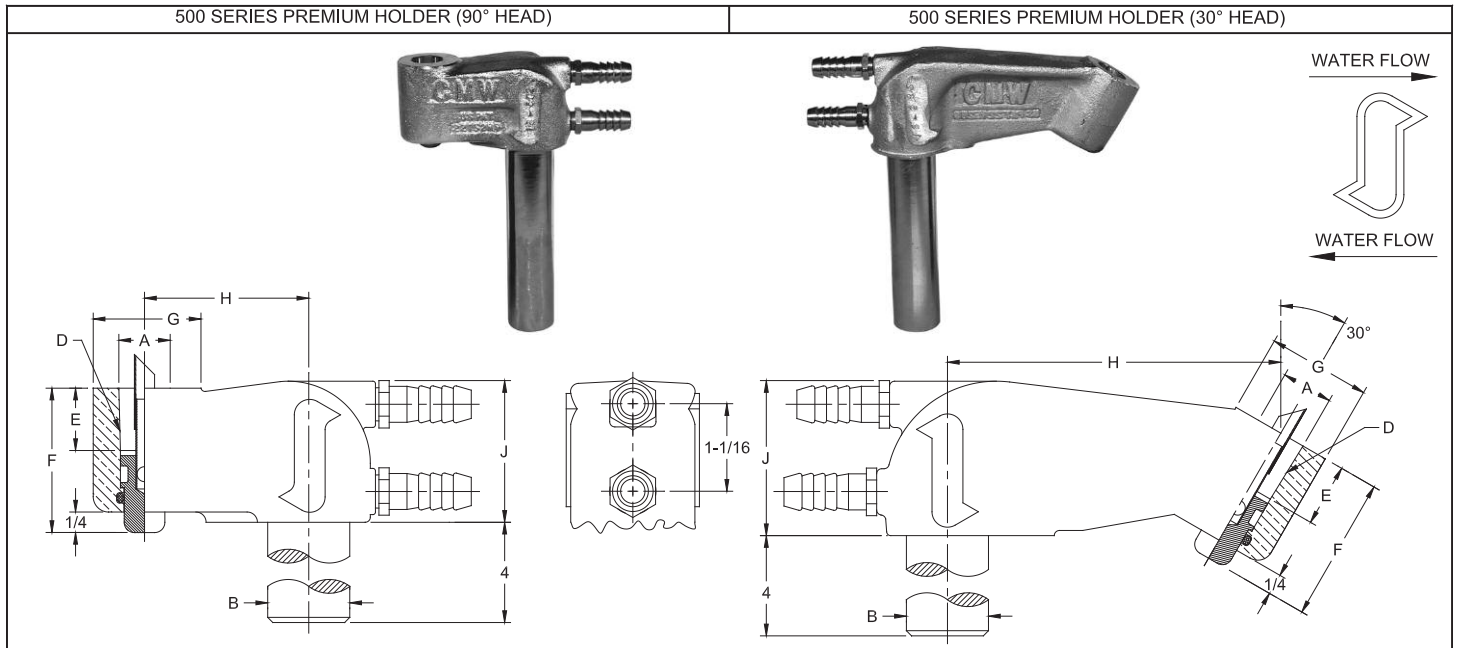

500 SERIES PREMIUM HOLDER (90° HEAD)								
Part No. Holder Assy.	Major Taper Dia. A*	Shank Dia. B*	RW Taper D	Engagement With Electrode E	Head Height F	Head Dia. G	Offset H	Head Thickness J
18-502		1						
18-503	.625	1-1/4	5 RW	3/4	1-13/16	1-1/4	2	1-23/32
18-504		1-1/2						
18-505	.875	1-1/4	7 RW	1-1/8	2-7/32	1-1/2	2	1-23/32
18-506		1-1/2						
18-522		1						
18-523	.625	1-1/4	5 RW	3/4	1-13/16	1-1/4	4	1-7/8
18-524		1-1/2						
18-525	.875	1-1/4	7 RW	1-1/8	2-7/32	1-1/2	4	1-7/8
18-526		1-1/2						

500 SERIES PREMIUM HOLDER (30° HEAD)								
Part No. Holder Assy.	Major Taper Dia. A*	Shank Dia. B*	RW Taper D	Engagement With Electrode E	Head Height F	Head Dia. G	Offset H	Head Thickness J
18-562		1						
18-563	.625	1-1/4	5 RW	3/4	1-13/16	1-5/16	4	1-7/8
18-564		1-1/2						
18-565	.875	1-1/4	7 RW	1-1/8	2-7/32	1-9/16	4	1-7/8
18-566		1-1/2						

*Other shank diameters and lengths or tapers available on special order

*Other shank diameters and lengths or tapers available on special order

500 SERIES PREMIUM (EJECTOR) WATER COOLED ELECTRODE HOLDERS WITH THREADED ADAPTERS

500 SERIES PREMIUM HOLDER WITH THREADED ADAPTERS										
Part No. Holder Assy.	Head Angle	Major Taper Dia. A*	Shank Dia. B*	RW Taper D	Engagement With Electrode E	Head Height F	Head Dia. G	Offset H	Head Thickness J	Part No. Threaded Adapter
18-5035	90°	.625	1-1/4	5 RW	3/4	1-13/16	1-1/4	2	1-23/32	18-7875
18-5036		.750		6 RW	7/8	1-15/16				18-7876
18-5045	90°	.625	1-1/2	5 RW	3/4	1-13/16	1-1/4	2	1-23/32	18-7875
18-5046		.750		6 RW	7/8	1-15/16				18-7876
18-5235	90°	.625	1-1/4	5 RW	3/4	1-13/16	1-1/4	4	1-7/8	18-7875
18-5236		.750		6 RW	7/8	1-15/16				18-7876
18-5245	90°	.625	1-1/2	5 RW	3/4	1-13/16	1-1/4	4	1-7/8	18-7875
18-5246		.750		6 RW	7/8	1-15/16				18-7876
18-5635	30°	.625	1-1/4	5 RW	3/4	1-13/16	1-1/4	4	1-7/8	18-7875
18-5636		.750		6 RW	7/8	1-15/16				18-7876
18-5645	30°	.625	1-1/2	5 RW	3/4	1-13/16	1-1/4	4	1-7/8	18-7875
18-5646		.750		6 RW	7/8	1-15/16				18-7876

*Other shank diameters and lengths or tapers available on special order

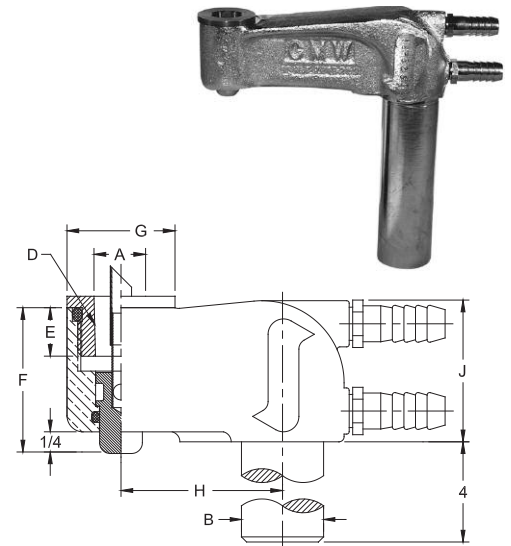



500 SERIES PREMIUM (EJECTOR) REPLACEMENT PARTS

Phone: 800-521-3722

Fax: 864-877-2212

Email: cmw@cmwinc.com

500 SERIES PREMIUM (EJECTOR) WATER COOLED OFFSET HOLDERS

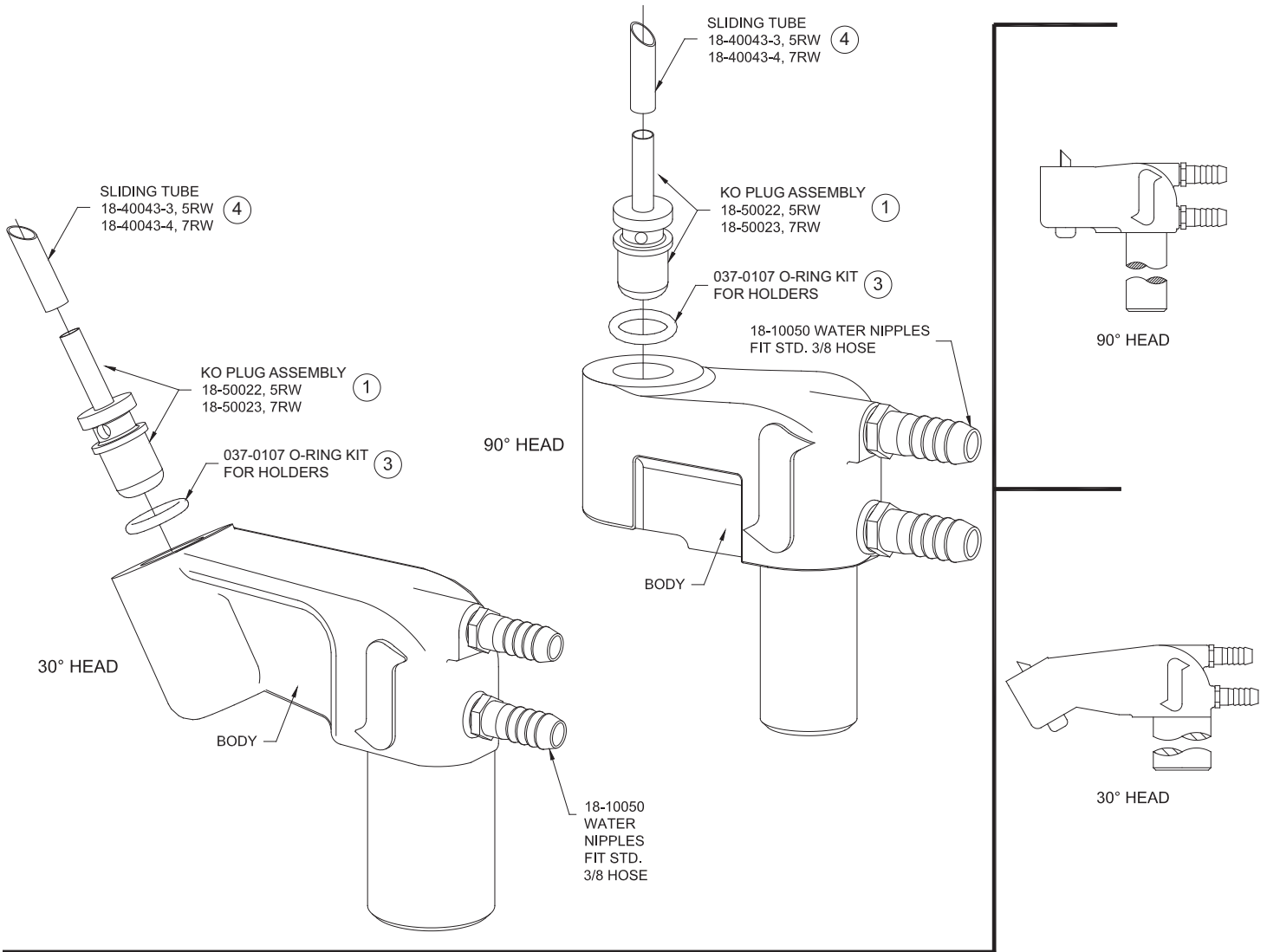

Part No. Holder Assy.	Taper	Angle Of Head	KO Plug Assembly 1	Sealing Ring 3	Sliding Tube 4	Shank Dia.
18-502 18-503 18-504	5 RW	90°	18-50022	18-10060-10	18-40043-3	1 1-1/4 1-1/2
18-505 18-506	7 RW	90°	18-50023	18-10060-12	18-40043-4	1-1/4 1-1/2
18-522 18-523 18-524	5 RW	90°	18-50022	18-10060-10	18-40043-3	1 1-1/4 1-1/2
18-525 18-526	7 RW	90°	18-50023	18-10060-12	18-40043-4	1-1/4 1-1/2
18-562 18-563 18-564	5 RW	30°	18-50022	18-10060-10	18-40043-3	1 1-1/4 1-1/2
18-565 18-566	7 RW	30°	18-50023	18-10060-12	18-40043-4	1-1/4 1-1/2

500 SERIES THREADED PREMIUM (EJECTOR) REPLACEMENT PARTS



Phone: 800-521-3722

Fax: 864-877-2212

Email: cmw@cmwinc.com

500 SERIES PREMIUM (EJECTOR) WATER COOLED OFFSET HOLDERS WITH THREADED ADAPTER

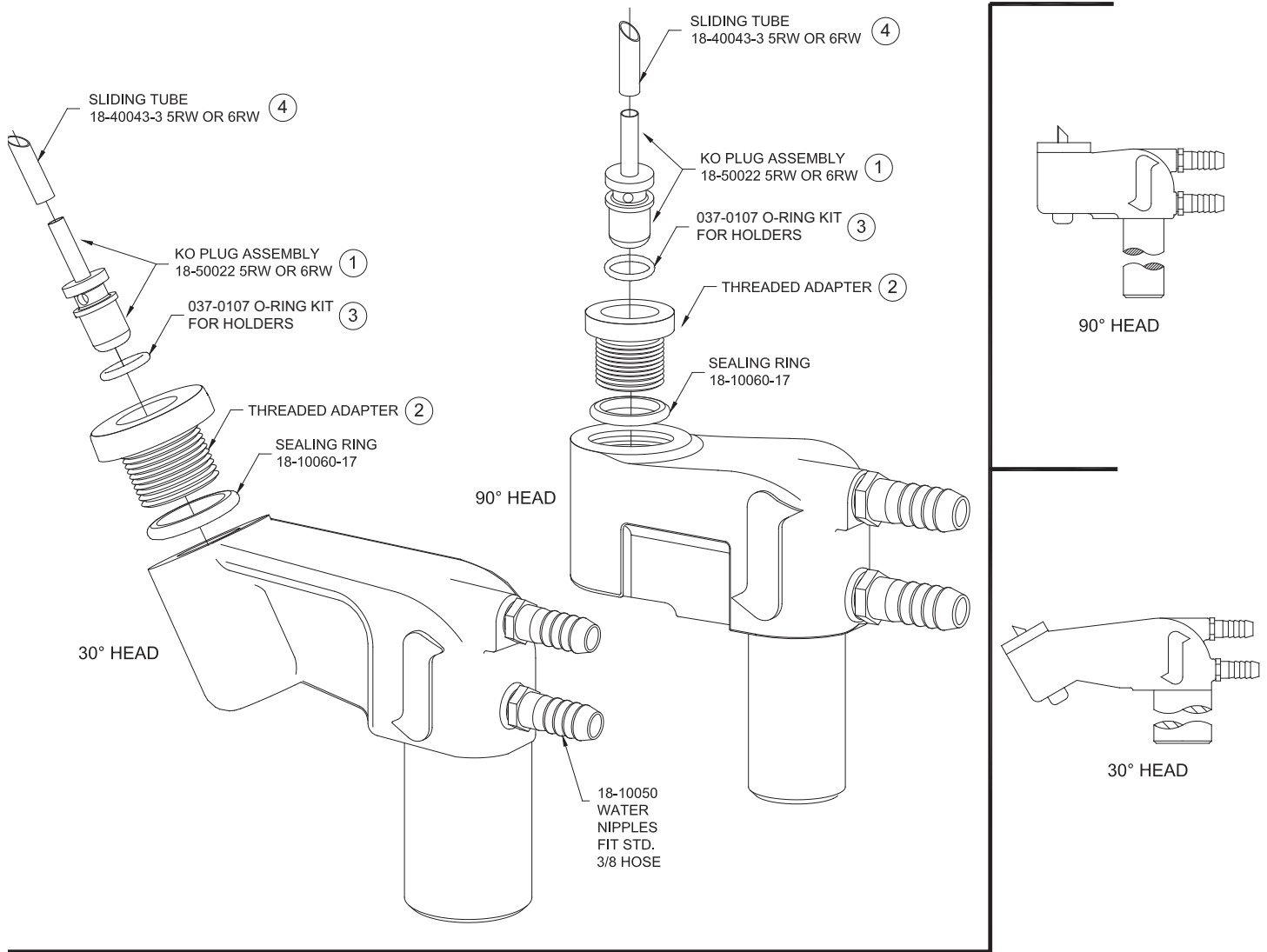

Part No. Holder Assy.	Taper	Angle Of Head	KO Plug Assembly 1	Sealing Ring 3	Sliding Tube 4	Shank Dia.	Threaded Adapter 2
18-5035 18-5036	5 RW 6 RW	90°	18-50022	18-10060-10	18-40043-3	1-1/4	18-7875 18-7876
18-5045 18-5046	5 RW 6 RW	90°	18-50022	18-10060-10	18-40043-3	1-1/2	18-7875 18-7876
18-5235 18-5236	5 RW 6 RW	90°	18-50022	18-10060-10	18-40043-3	1-1/4	18-7875 18-7876
18-5245 18-5246	5 RW 6 RW	90°	18-50022	18-10060-10	18-40043-3	1-1/2	18-7875 18-7876
18-5635 18-5636	5 RW 6 RW	30°	18-50022	18-10060-10	18-40043-3	1-1/4	18-7875 18-7876
18-5645 18-5646	5 RW 6 RW	30°	18-50022	18-10060-10	18-40043-3	1-1/2	18-7875 18-7876

600 SERIES UNIVERSAL WATER COOLED ELECTRODE HOLDERS

Phone: 800-521-3722

Fax: 864-877-2212

Email: cmw@cmwinc.com

600 SERIES UNIVERSAL WATER COOLED ELECTRODE HOLDERS

EXAMPLE: This is shown with standard 90° adapter head and 600 series water connector body 18-74001 "Type A"

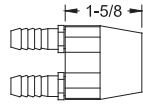
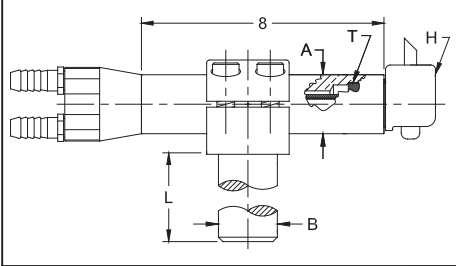

TYPE (A)
600 Series Water Connector Body 18-74001

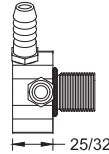

TYPE (C)
100 Series Water Connector Body 18-10042

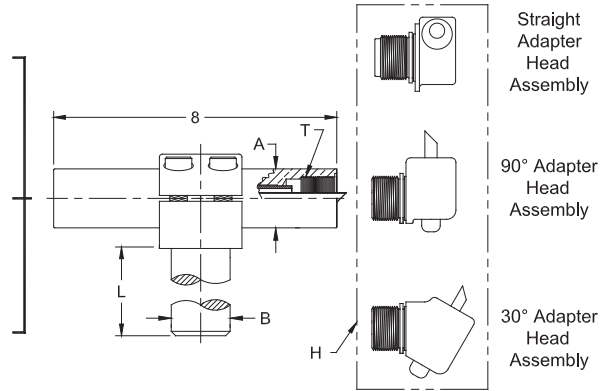

*Standard holders include type "A" water connector, types "B" and "C" available on request. See page 46 for adapter head details and page 47 for additional "T" connector information.

600 SERIES UNIVERSAL HOLDER (90° ADAPTER HEAD)						
Part No. Holder Assy.*	Taper	Barrel Dia. A	Shank Dia B	Shank Length L	Head Assy. H	Barrel Thread Size T
18-601 18-603	5 RW	1	7/8	3	18-764	7/8-14
		1	1	3		
18-605 18-607	5 RW	1-1/4	1-1/4	3-1/2	18-764	7/8-14
		1-1/4	1-1/2	4		
18-611 18-613	5 RW	1	7/8	3	18-766	7/8-14
		1	1	3		
18-615 18-617	5 RW	1-1/4	1-1/4	3-1/2	18-766	7/8-14
		1-1/4	1-1/2	4		
18-651 18-657	5 RW	1-1/4	1-1/4	3-1/2	18-780	1-14
		1-1/4	1-1/2	4		
18-655 18-653	5 RW	1-1/2	1-1/4	4	18-780	1-14
		1-1/2	1-1/2	4		
18-661 18-665 18-663	7 RW	1-1/4	1-1/4	3-1/2	18-782	1-14
		1-1/2	1-1/4	4		
		1-1/2	1-1/2	4		



600 SERIES UNIVERSAL HOLDER (STRAIGHT ADAPTER HEAD)						
Part No. Holder Assy.*	Taper	Barrel Dia. A	Shank Dia B	Shank Length L	Head Assy. H	Barrel Thread Size T
18-621 18-622	4 RW	1	7/8	3	18-768	7/8-14
		1	1	3		
18-623 18-671	4 RW	1-1/4	1-1/4	3-1/2	18-768	7/8-14
		1-1/4	1-1/4	3-1/2	18-784	1-14
18-624 18-674	5 RW	1-1/4	1-1/2	4	18-768	7/8-14
		1-1/4	1-1/2	4	18-784	1-14
18-672 18-673	5 RW	1-1/2	1-1/2	4	18-784	1-14
		1-1/2	1-1/4	4		

600 SERIES UNIVERSAL HOLDER (30° ADAPTER HEAD)						
Part No. Holder Assy.*	Taper	Barrel Dia. A	Shank Dia B	Shank Length L	Head Assy. H	Barrel Thread Size T
18-602 18-604	4 RW	1	7/8	3	18-765	7/8-14
		1	1	3		
18-606 18-608	4 RW	1-1/4	1-1/4	3-1/2	18-765	7/8-14
		1-1/4	1-1/2	4		
18-612 18-614	5 RW	1	7/8	3	18-767	7/8-14
		1	1	3		
18-616 18-618	5 RW	1-1/4	1-1/4	3-1/2	18-767	7/8-14
		1-1/4	1-1/2	4		
18-652 18-658	5 RW	1-1/4	1-1/4	3-1/2	18-781	1-14
		1-1/4	1-1/2	4		
18-656 18-654	5 RW	1-1/2	1-1/4	4	18-781	1-14
		1-1/2	1-1/2	4		
18-662 18-666 18-664	7 RW	1-1/4	1-1/4	3-1/2	18-783	1-14
		1-1/2	1-1/4	4		
		1-1/2	1-1/2	4		

600 SERIES UNIVERSAL WATER COOLED ELECTRODE HOLDER (THREADED ADAPTER HEAD)

600 SERIES UNIVERSAL HOLDER (THREADED ADAPTER HEAD)							
Part No. Holder Assy.*	Taper	Head Angle	Barrel Dia. A	Shank Dia B	Shank Length L	Head Assy. H	Barrel Thread Size T
18-6515 18-6535	5 RW	90°	1-1/4	1-1/4	3-1/2	18-7805	1-14
		30°	1-1/4	1-1/2	4		
18-6525 18-6545	5 RW	30°	1-1/4	1-1/4	3-1/2	18-7815	1-14
		30°	1-1/4	1-1/2	4		
18-6516 18-6536	6 RW	90°	1-1/4	1-1/4	3-1/2	18-7806	1-14
		90°	1-1/4	1-1/2	4		
18-6526 18-6546	6 RW	30°	1-1/4	1-1/4	3-1/2	18-7816	1-14
		30°	1-1/4	1-1/2	4		

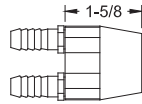

TYPE (A)
600 Series Water Connector Body 18-74001

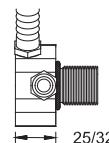

TYPE (C)
100 Series Water Connector Body 18-10042

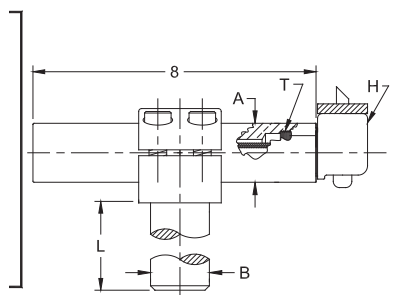

*Standard holders include type "A" water connector, types "B" and "C" available on request

600 SERIES UNIVERSAL REPLACEMENT PARTS



Phone: 800-521-3722

Fax: 864-877-2212

Email: cmw@cmwinc.com

600 SERIES UNIVERSAL WATER COOLED OFFSET HOLDERS

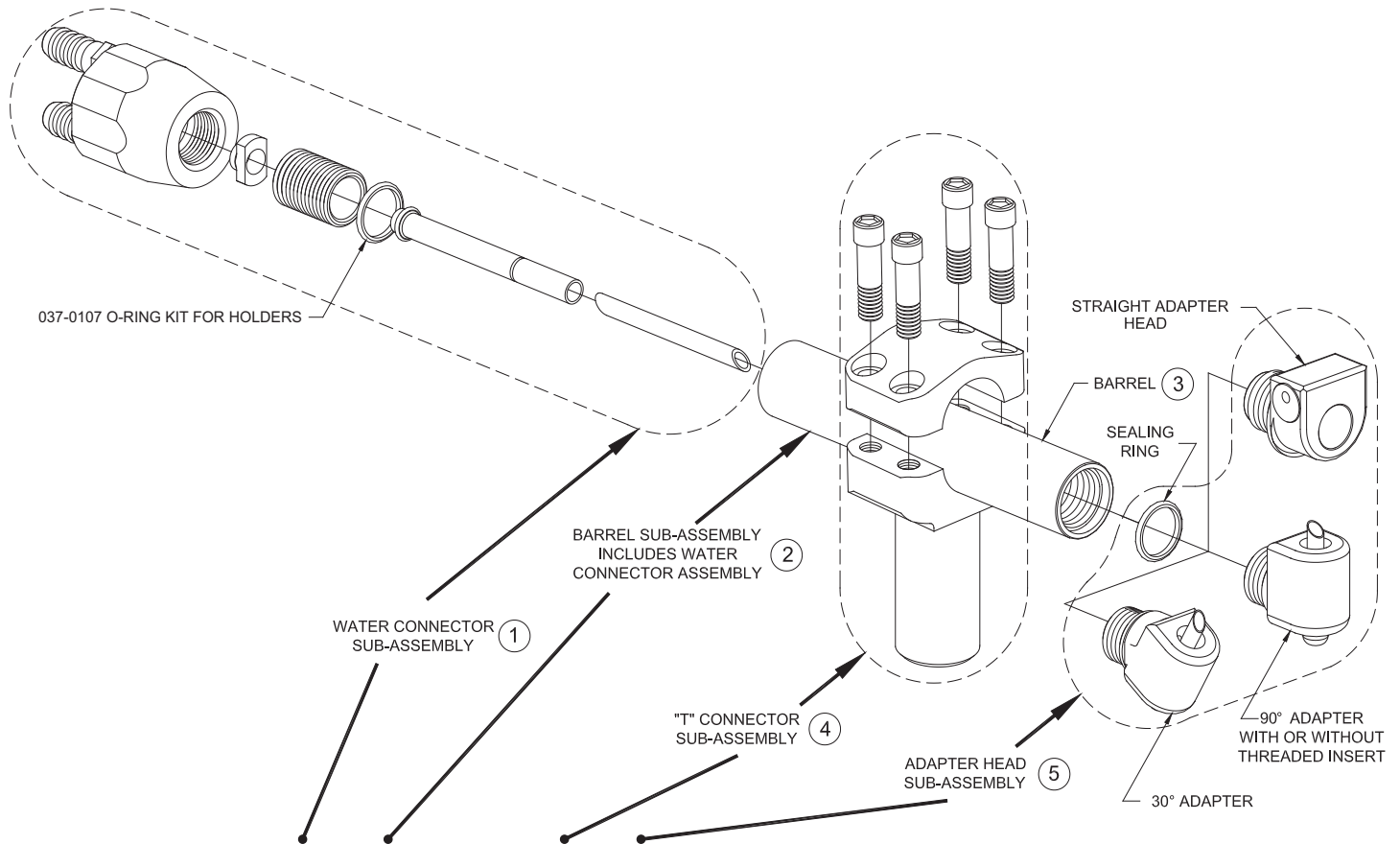

Part No. Holder Assy.	Taper	Angle Of Head	Water Conn. Assembly 1	Barrel Assy. 2	Barrel 3	"T" Conn. Assy.* 4	Adapter Head Assy.* 5	
18-601 18-602	4 RW	90°	18-74000-8	18-701	18-37210-8	18-725	18-764	
18-603 18-604		30°					18-765	
18-605 18-606		90°	18-702			18-37310-8	18-727	18-764
18-607 18-608		30°					18-765	18-764
18-611 18-612	5 RW	90°	18-74000-8	18-701	18-37210-8	18-725	18-766	
18-613 18-614		30°					18-767	
18-615 18-616		90°	18-702			18-37310-8	18-727	18-766
18-617 18-618		30°					18-767	18-766
18-621 18-622		STR. STR.	18-74000-8	18-701	18-37210-8	18-725	18-768	
18-623 18-624		STR. STR.				18-727	18-768	
18-651 18-652		90°	18-74000-8	18-704	18-37510-8	18-727	18-780	
18-657 18-658		30°				18-781	18-780	
			90°			18-730	18-781	

Part No. Holder Assy.	Taper	Angle Of Head	Water Conn. Assembly* 1	Barrel Assy. 2	Barrel 3	"T" Conn. Assy.* 4	Adapter Head Assy.* 5		
18-655 18-656	5 RW	90°	18-74000-8	18-705	18-37610-8	18-728	18-780		
18-653 18-654		30°					18-765		
18-671 18-672		STR. STR.	18-704			18-37510-8	18-727	18-784	
18-673 18-674		STR. STR.	18-705			18-37610-8	18-728	18-784	
18-6515 18-6525	5 RW THD.	90°	18-74000-8	18-704	18-37510-8	18-727	18-7805		
18-6535 18-6545		30°					18-705	18-37610-8	18-729
18-6516 18-6526		90°	18-74000-8			18-705	18-37610-8	18-727	18-7806
18-6536 18-6546	30°	18-704		18-37510-8	18-729			18-7816	
18-661 18-662	7 RW	90°	18-74000-8	18-704	18-37510-8	18-727	18-782		
18-665 18-666		30°					18-783		
18-663 18-664		90°	18-74000-8			18-705	18-37610-8	18-728	18-782
		30°						18-783	18-729

* See page 46 for adapter head details and page 47 for additional "T" connector information.

MALE THREAD TO FEMALE TAPER UNIVERSAL ADAPTERS

Phone: 800-521-3722

Fax: 864-877-2212

Email: cmw@cmwinc.com

MALE THREAD TO FEMALE TAPER UNIVERSAL ADAPTERS

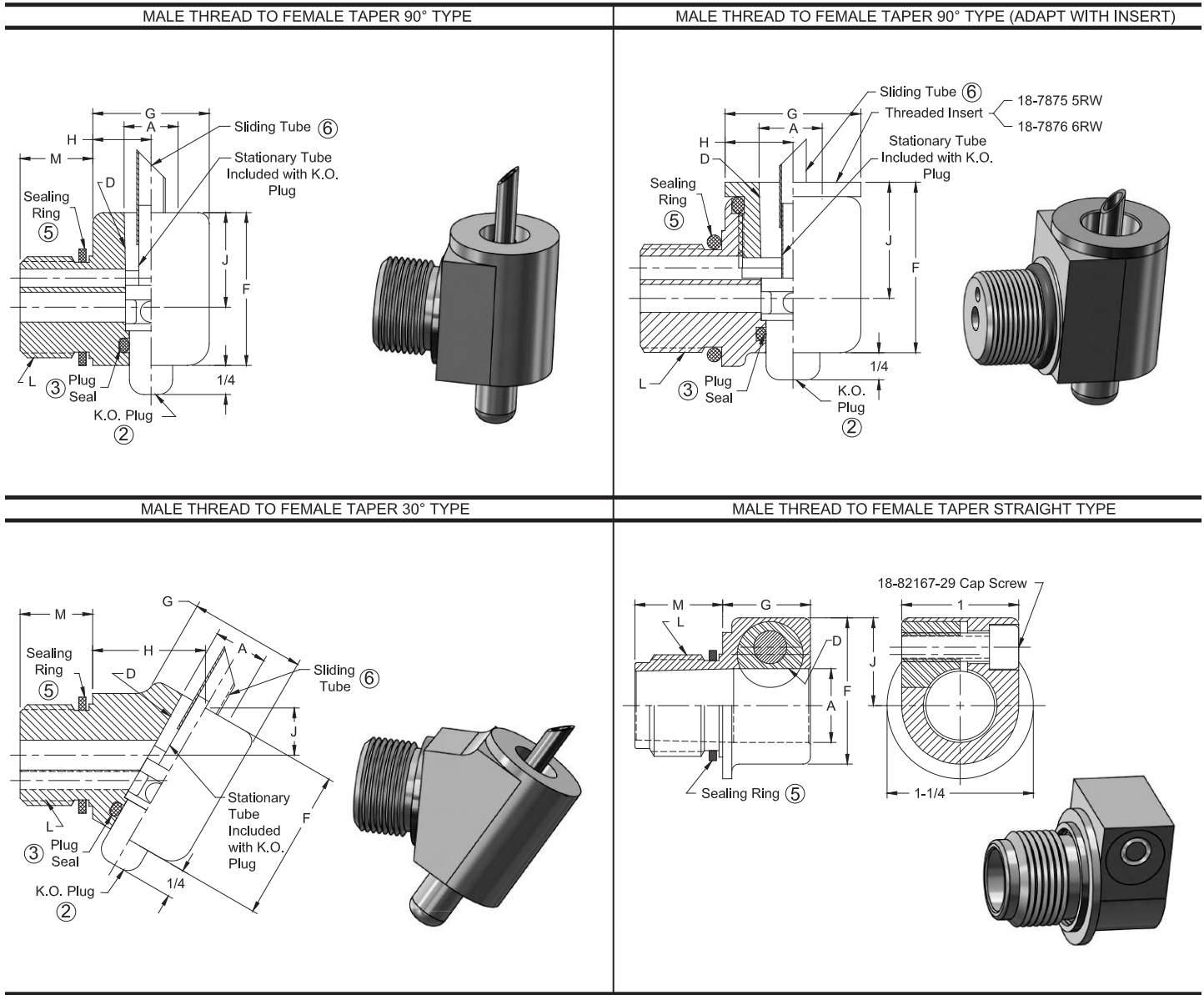

MALE THREAD TO FEMALE TAPER UNIVERSAL ADAPTERS

Adapter Part No.	Adapter Angle	Male Thread		Female Taper		Overall Head Height	Head Diameter or Length	End Barrel to C.L. of Taper	C.L. Barrel to C.L. of Taper	K.O. Plug Part No.	K.O. Plug Seal Ring Part No.	Sealing Ring Part No.	Sliding Tube Part No.
		Thread Size L	Length M	Taper Size D	Major Dia. A								
18-764 18-765	90° 30°	7/8-14	9/16	4 RW	.463	1-9/16	1	19/32 1-1/16	13/16 15/32	18-50021	18-10060-8	18-76460	18-50041-1
18-766 18-767 18-768	90° 30° Str.	7/8-14	9/16	5 RW	.625	1-13/16 1-13/16 1-1/4	1 1-1/16 3/4	19/32 1-11/32 --	1-1/16 53/64 3/4	18-50022	18-10060-10	18-76460	18-40043-3 18-40043-3 --
18-780 18-781 18-784	90° 30° Str.	1-14	3/4	5 RW	.625	1-13/16 1-13/16 1-1/4	1-1/4 1-5/16 3/4	21/32 1-3/8 --	1-1/16 13/16 3/4	18-50022	18-10060-10	18-10060-17	18-40043-3 18-40043-3 --
18-782 18-783	90° 30°	1-14	3/4	7 RW	.875	2-3/16	1-1/2 1-9/16	25/32 1-3/8	1-3/16 13/16	18-50023	18-10060-12	18-10060-17	18-40043-4
18-7805* 18-7815*	90° 30°	1-14	3/4	5 RW	.625	1-13/16	1-1/4 1-5/16	21/32 1-3/8	1-1/16 13/16	18-50022	18-10060-10	18-10060-17	18-40043-3
18-7806* 18-7816*	90° 30°	1-14	3/4	6 RW	.750	1-15/16	1-1/4 1-5/16	21/32 1-7/16	1-3/16 59/64	18-50022	18-10060-10	18-10060-17	18-40043-3

*These adapters have threaded inserts 18-7875 (5RW) or 18-7876 (6RW) taper

"T" CONNECTORS FOR HOLDERS



Phone: 800-521-3722

Fax: 864-877-2212

Email: cmw@cmwinc.com

"T" CONNECTORS FOR HOLDERS

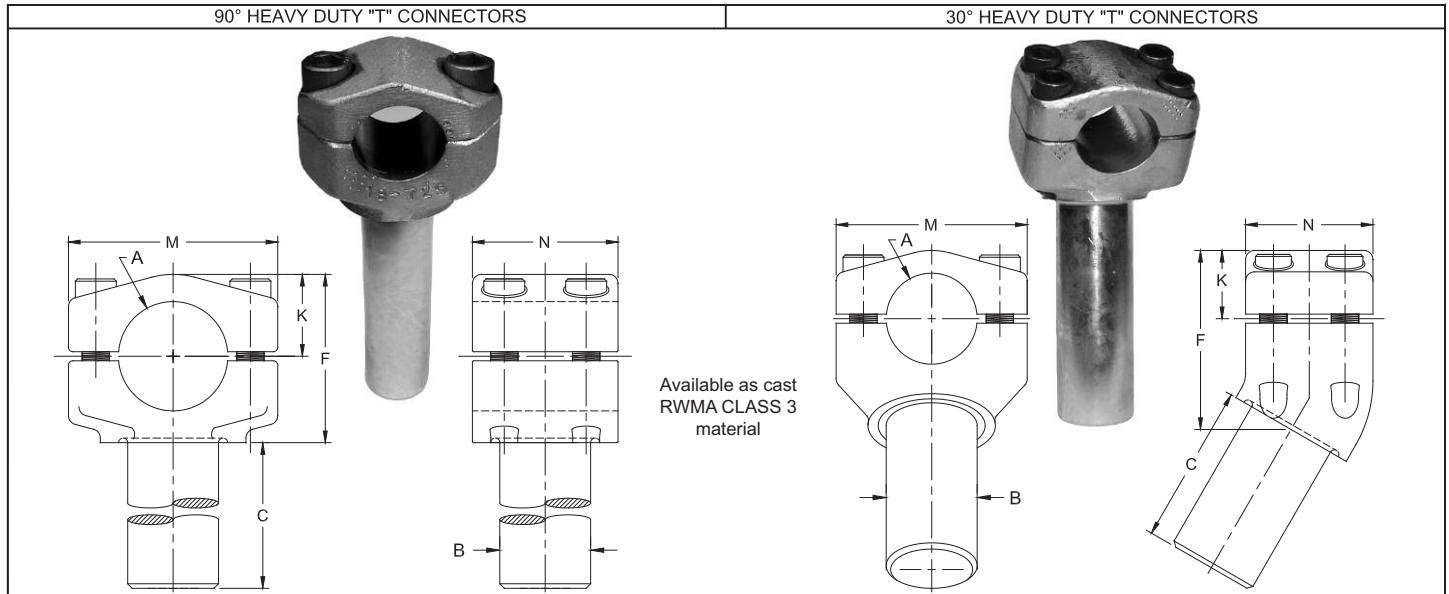

HEAVY DUTY 90° "T" CONNECTORS								
"T" Connector Assy. No.	Hole Dia. A	Shank Dia. B*	Shank Length C	Head Height F	Hole C.L. Over Top K	Length M	Width N	Number of Bolts
18-725 18-726	1	7/8 1	3	1-3/4	3/4	2-5/16	1-1/2	2 Bolt
18-727 18-728	1-1/4 1-1/2	1-1/4	3-1/2 4	2 2-5/16	15/16 1-1/8	2-5/8 2-7/8	1-3/4 2	4 Bolt
18-729 18-730	1-1/2 1-1/4	1-1/2	4	2-5/16	1-1/8	2-7/8	2	

HEAVY DUTY 30° "T" CONNECTORS								
"T" Connector Assy. No.	Hole Dia. A	Shank Dia. B	Shank Length C	Head Height F	Hole C.L. Over Top K	Length M	Width N	Number of Bolts
18-731 18-732	1	7/8 1	3	2	3/4	2-5/16	1-1/2	2 Bolt
18-733 18-734	1-1/4 1-1/2	1-1/4 1-1/2	3-1/2 4	2-13/32 2-47/64	15/16 1-1/8	2-5/8 2-7/8	1-3/4 2	4 Bolt

These 30° "T" Connectors may be interchangeable with the 90° universal type "T" Connectors. See page 38 for suggested setups.

"T" Connectors of other shank diameters and lengths may be ordered upon request.

Available as cast RWMA CLASS 2 material

SMALL BARREL 90° "T" CONNECTORS							
"T" Connector Assy. No.	Hole Dia. A	Shank Dia. B	Shank Length C	Head Height F	Hole C.L. Over Top K	Dia. M	Number of Bolts
18-720 18-721	3/4	3/4 7/8	3	1-1/4	5/8	1-1/2	1 Bolt
18-722 18-723 18-724		1 1-1/4 1-1/2					

"T" Connectors of other shank diameters and lengths may be ordered upon request.

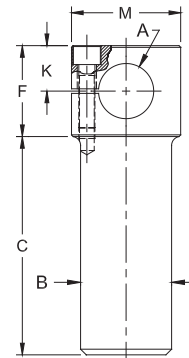

THREADED SOCKET (OR BUTTON) ELECTRODES

(USE WITH 900 AND 950 SERIES HOLDERS ON PAGE 48) ALL DIMENSIONS WITH AN (*) ARE COMMON TO EACH CAP IN A HORIZONTAL LINE.

FLAT FACE	TRUNCATED FACE	RADIUS FACE	OFFSET FACE	30° OFFSET FACE
<p>RWMA CLASS 1 18-970 RWMA CLASS 2 18-980 RWMA CLASS 3 18-990</p>	<p>RWMA CLASS 1 18-971 RWMA CLASS 2 18-981 RWMA CLASS 3 18-991</p>	<p>RWMA CLASS 1 18-972 RWMA CLASS 2 18-982 RWMA CLASS 3 18-992</p>	<p>RWMA CLASS 1 18-973 RWMA CLASS 2 18-983 RWMA CLASS 3 18-993</p>	<p>RWMA CLASS 1 18-974 RWMA CLASS 2 18-984 RWMA CLASS 3 18-994</p>

900 SERIES UNIVERSAL & 950 SERIES PADDLE WATER COOLED HOLDERS

Phone: 800-521-3722

Fax: 864-877-2212

Email: cmw@cmwinc.com

900 SERIES LIGHT DUTY WATER COOLED UNIVERSAL HOLDER

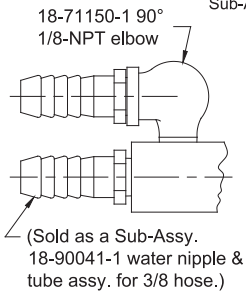
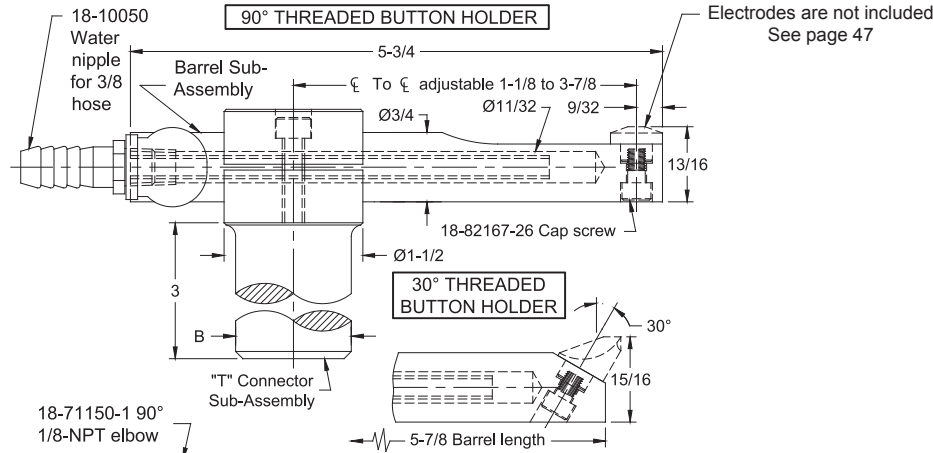

Holder Type	Holder Assembly Part No.	Holder Angle	Shank Dia. B	Barrel Sub-Assy.	Barrel	"T" Conn.
Threaded Button	18-901	90°	3/4	18-709	18-70910-1	18-720
	18-902	30°	3/4	18-710	18-71010-1	18-720
	18-903	90°	7/8	18-709	18-70910-1	18-721
	18-904	30°	7/8	18-710	18-71010-1	18-721
	18-905	90°	1	18-709	18-70910-1	18-722
	18-906	30°	1	18-710	18-71010-1	18-722
	18-907	90°	1-1/4	18-709	18-70910-1	18-723
	18-908	30°	1-1/4	18-710	18-71010-1	18-723
	18-909	90°	1-1/2	18-709	18-70910-1	18-724
	18-900	30°	1-1/2	18-710	18-71010-1	18-724

950 SERIES WATER COOLED PADDLE HOLDERS FOR THREADED BUTTON ELECTRODES

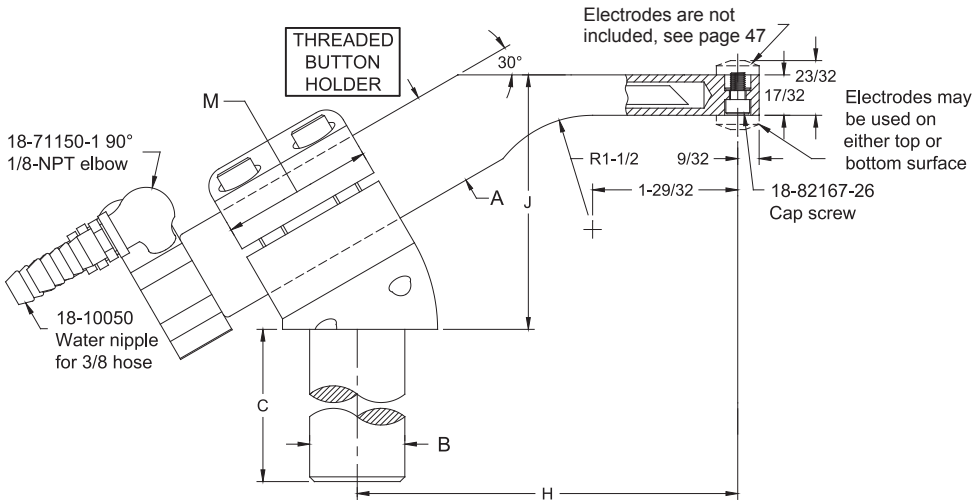

Holder Type	Holder Assembly Part No.	Barrel Dia. A	Shank Dia. B	Shank Length C	Offset Range H	Height Range J	Width M	Barrel Sub-Assy.	"T" Conn.
Threaded Button	18-952	1	7/8	3	3-3/8 to 5-3/32	2-1/16 to 3-1/16	1-1/2	18-713	18-731
	18-953	1	1	1	3-3/8 to 5-3/32	2-1/16 to 3-1/16	1-1/2	18-713	18-732
	18-954	1-1/4	1-1/4	3-1/2	4 to 5-23/32	2-3/4 to 3-3/4	1-3/4	18-714	18-733
	18-955	1-1/2	1-1/2	4	4-7/32 to 5-15/16	2-7/8 to 3-7/8	2	18-715	18-734

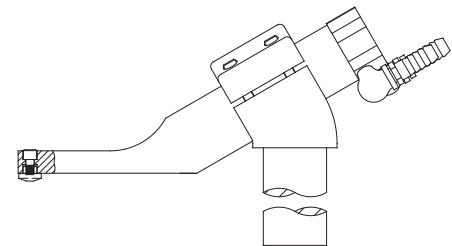

VIEW IS SHOWING BARREL SUB-ASSY AND ELECTRODE REVERSED IN SHANK

PLATEN MOUNTED ELECTRODE HOLDERS



Phone: 800-521-3722

Fax: 864-877-2212

Email: cmw@cmwinc.com

PLATEN MOUNTED ELECTRODE HOLDERS

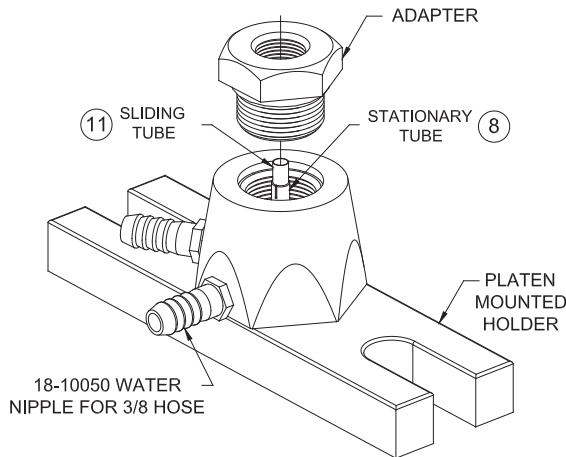

The CMW Platen Mounted Holder, as shown below, has the inlet water nipple at position #1 and the outlet water nipple at position #2, any other combinations may be special ordered by changing the last two digits of the part number. The first of the last two digits indicates the location of the inlet nipple and the second digit indicates the location of the outlet nipple. Example; part No. 18-0510-56 would place the inlet water nipple at position #5 and the outlet water nipple at position #6.

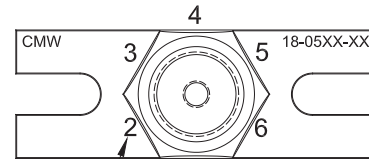

Standard Water Outlet 1 Standard Water Inlet

Part No. 18-0510-12 & 18-0520-12
(Without adapter & sliding tube)

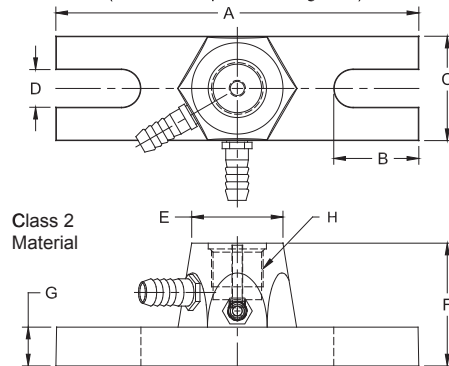

Order one of each for your application		Order as required				Overall Length A	Slot Depth B	Width C	Slot Width D	Top Dia. E	Overall Height F	Base Height G	Thread H
Holder Part No.	Adapter Part No.	Attachment Type	Stationary Tube 8	Sliding Tube 11	Sliding Length								
18-0510-12	18-785	4RW	18-40041-5	18-50041-3 18-50041-2	1-3/8 2-1/2	4-1/4	1	1-1/2	1/2	1-23/64	2-1/8	1/2	1-14 UNF
18-0520-12	18-785	4RW	18-40041-5	18-50041-3 18-50041-2	1-3/8 2-1/2	7	1-5/8	2	3/4	1-49/64	2-3/8	3/4	
18-0510-12	18-786	5RW	18-40041-5	18-40043-11 18-40043-5 18-40043-9	1-3/8 2 4	4-1/4	1	1-1/2	1/2	1-23/64	2-1/8	1/2	
18-0520-12	18-786	5RW	18-40041-5	18-40043-11 18-40043-5 18-40043-9	1-3/8 2 4	7	1-5/8	2	3/4	1-49/64	2-3/8	3/4	
18-0510-12	18-7863	6RW	18-40041-5	18-40043-14 18-40043-9	2-1/8 4	4-1/4	1	1-1/2	1/2	1-23/64	2-1/8	1/2	
18-0520-12	18-7863	6RW	18-40041-5	18-40043-14 18-40043-9	2-1/8 4	7	1-5/8	2	3/4	1-49/64	2-3/8	3/4	
18-0510-12	18-787	7RW	18-40041-5	18-40043-15 18-40043-9	2-3/8 4	4-1/4	1	1-1/2	1/2	1-23/64	2-1/8	1/2	
18-0520-12	18-787	7RW	18-40041-5	18-40043-15 18-40043-9	2-3/8 4	7	1-5/8	2	3/4	1-49/64	2-3/8	3/4	
18-0510-12	18-812	#2 SIZE Nu-Twist ^o	18-40041-5	-	-	4-1/4	1	1-1/2	1/2	1-23/64	2-1/8	1/2	
	18-7743**	5/8-18 THD.											
18-0520-12	18-812	#2 SIZE Nu-Twist ^o	18-40041-5	-	-	7	1-5/8	2	3/4	1-49/64	2-3/8	3/4	
	18-7743**	5/8-18 THD.											

**Adapter for 1" dia. & 1-1/4 dia. Chameleon/Max-Life™ projection welding electrodes and 18-811 #1 size threaded "NU-TWIST"^o adapter.



800 SERIES "NU-TWIST"® ADAPTERS

Phone: 800-521-3722

Fax: 864-877-2212

Email: cmw@cmwinc.com

800 SERIES "NU-TWIST"® ADAPTERS

CMW "NU-TWIST"® FEATURES

1. Hex locking nut may be tightened or loosened effectively by hand or wrench for easy replacement of electrodes.
2. "O" ring seals provide water tight connections.
3. Double groove construction in bore or locking nut accurately aligns and locks the

electrode in position with a maximum of a turn and one half.

4. Through use of baffles in adapters and in electrodes over 1" long efficient cooling is effectively achieved.
5. All components are of corrosion-resistant alloys.
6. Maintenance costs are unusually low.
7. Adapter bases are RWMA CLASS 2 material.

SURFACE MOUNTED ADAPTERS

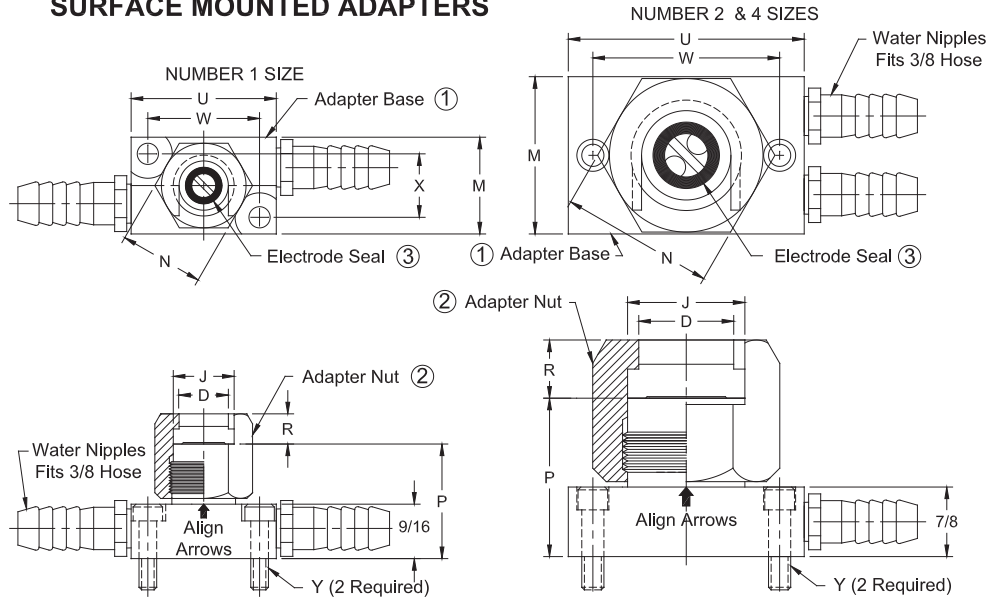

800 SERIES "NU-TWIST"® SURFACE MOUNTED											
Size	Adapter Part No.	Adapter Size									
		D	J	M	N	P	R	U	W	X	Y
1	18-801	1/2	5/8	1	7/8	1-1/4	1/4	1-1/2	1-5/32	21/32	No. 10-24 Scr.
2	18-802	15/16	1-1/8	1-1/2	1-1/2	1-13/16	7/16	2-1/2	2	--	No. 1/4-20 Scr.
4	18-804	1-7/16	1-5/8	2	2	1-13/16	7/16	3	2-3/8	--	No. 1/4-20 Scr.

REPLACEMENT PARTS				
Adapter Part No.	Water Nipples	Adapter Base 1	Adapter Nut 2	Electrode Seals 3
18-801		18-80110	18-80150	18-10060-5
18-802	18-10050	18-80210	18-80250	18-10060-1
18-804		18-80410	18-80450	18-10061-14

For replacement parts see page 51

800 SERIES "NU-TWIST"® THREADED ADAPTERS & MOUNTING INFORMATION

May use with 100, 200, and 300 series holders to make "NU-TWIST"® holders

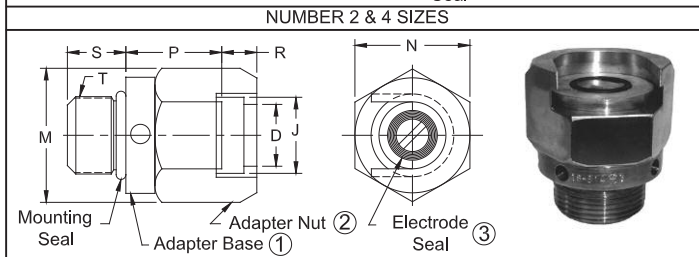
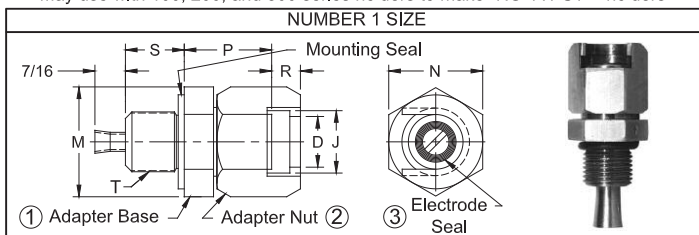

800 SERIES "NU-TWIST"® THREADED										
Size	Adapter Part No.	Adapter Size								
		D	J	M	N	P	R	S	T (Thread)	
1	18-811	1/2	5/8	1	7/8	15/16	1/4	9/16	5/8-18	
2	18-812	15/16	1-1/8	1-1/2	1-1/2	1-5/16	7/16	3/4	1-14	
4	18-814	1-7/16	1-5/8	2	2	1-5/16	7/16	3/4	1-1/2-12	

For replacement parts see page 51

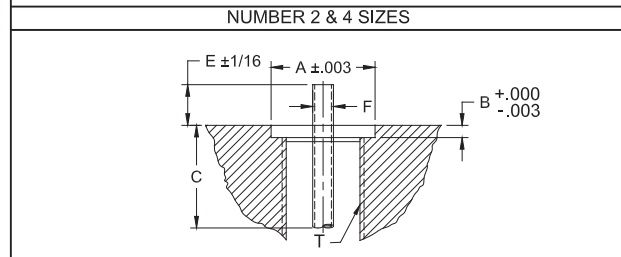
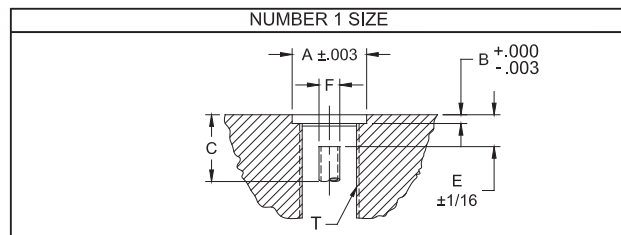

MOUNTING INFORMATION FOR THREADED ADAPTERS							
Size	Thd. Adapter Assy. No.	C'bore Dia. A	C'bore Depth B	Thread Depth Min. C	Tube Height E	Tube Dia. F	Thread T
1	18-811	.750	.083	5/8	3/8	.244	5/8-18
2	18-812	1.126	.113	13/16	15/16	.244	1-14
4	18-814	1.626	.173	13/16	15/16	.375	1-1/2-12

800 SERIES "NU-TWIST"® THREADED ADAPTER REPLACEMENT PARTS



Phone: 800-521-3722

Fax: 864-877-2212

Email: cmw@cmwinc.com

800 SERIES "NU-TWIST"® THREADED ADAPTERS

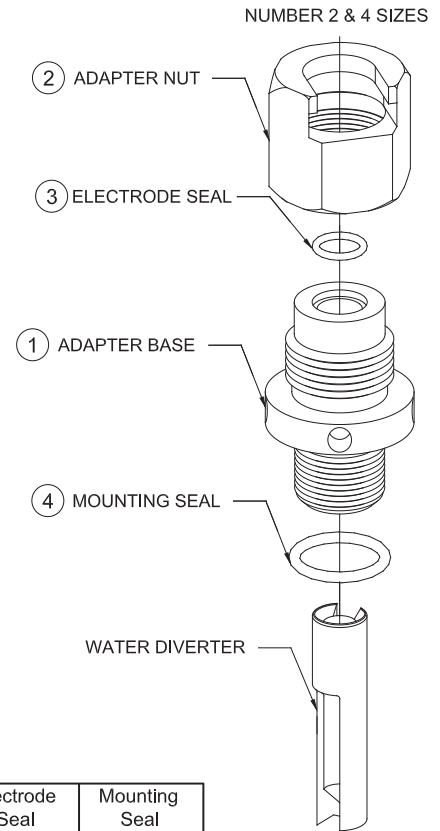
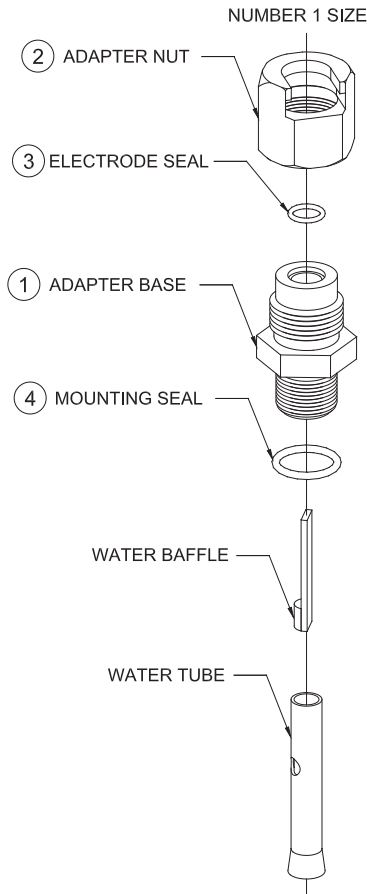

Adapter Assembly Part No.	Adapter Base* 1	Adapter Nut 2	Electrode Seal 3	Mounting Seal 4
18-811	18-81110	18-80150	18-10061-5	18-10060-11
18-812	18-81210	18-80250	18-10061-10	18-10060-17
18-814	18-81410	18-80450	18-10061-14	18-10060-25

* Adapter base includes water tube & baffel or water diverter

"NU-TWIST"® ELECTRODES

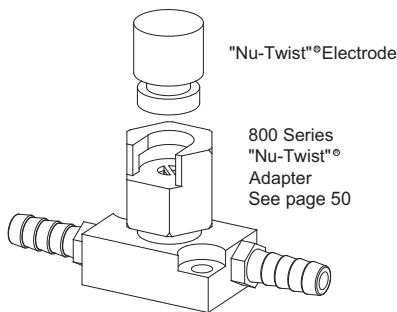

- No tapers or threads
- Can be extracted with a simple turn of hexagon locking nut
- Any contour in electrode face can be located or relocated in a given position
- Water circulated to end of electrode for maximum cooling
- Silver plated contact surfaces on electrode and base for maximum conductivity
- Provides a simple, low-cost electrode for most applications
- Electrodes shown can be modified with contours to provide faces required for most resistance welding applications

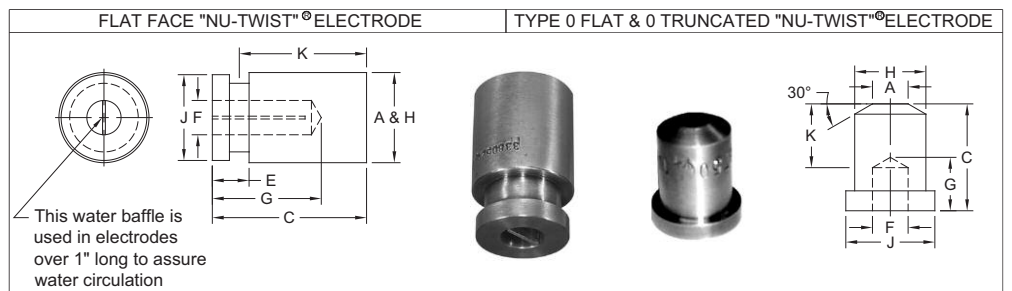

Size	Type	Electrode Part No.		Body Dia. H	Weld Face Dia. A	Overall Length C	Adapter Clearance E	Water Hole Dia. F	Water Hole Depth G	Electrode Seat Dia. J	Elect. Ext. From Adapt. K
		RWMA CLASS 2	RWMA CLASS 3								
1	0 Flat	338750	538750	1/2	1/2	3/4	--	1/4	3/8	.625	1/2
		338030	538030	1/2	1/2	1-1/2	--	1/4	1-1/8	.625	1-1/4
1	0 Trunc.	378750	578750	1/2	1/4	3/4	--	1/4	3/8	.625	1/2
		378030	578030	1/2	1/4	1-1/2	--	1/4	1-1/8	.625	1-1/4
1	Flat	338751	538751	5/8	5/8	3/4	5/16	1/4	3/8	.625	1/2
		338031	538031	5/8	5/8	1-1/2	5/16	1/4	1-1/8	.625	1-1/4
2	Flat	338012	538012	1-1/4	1-1/4	1	5/8	1/2	1/2	1.125	1/2
		338052	538052	1-1/4	1-1/4	2	5/8	1/2	1-1/2	1.125	1-1/2
4	Flat	338014	538014	1-3/4	1-3/4	1	5/8	3/4	1/2	1.625	1/2
		338054	538054	1-3/4	1-3/4	2	5/8	3/4	1-1/2	1.625	1-1/2

Special face contours, lengths and diameters available on special order

CMW[®] FIXED UNIT HYDRAULIC EQUALIZING ASSEMBLIES (WATER COOLED)

Phone: 800-521-3722

Fax: 864-877-2212

Email: cmw@cmwinc.com

FIXED UNIT HYDRAULIC EQUALIZING ASSEMBLIES

CMW Hydraulic Equalizing adapter units are used to equalize the weld force when two or more welds are required simultaneously. The equalizing action is developed in a closed hydraulic system - and is accomplished by hydraulically interconnecting two or more units. We recommend using fire resistant hydraulic fluid compatible with BUNA "N" such as HOUGHTO-SAFE #620, 1120 or equivalent. Consult your local industrial lubricant distributor.

TWO #1 OR #2 SIZE HYDRAULIC UNITS MOUNTED TO CUSTOMER'S DESIRED ELECTRODE SPACING.*

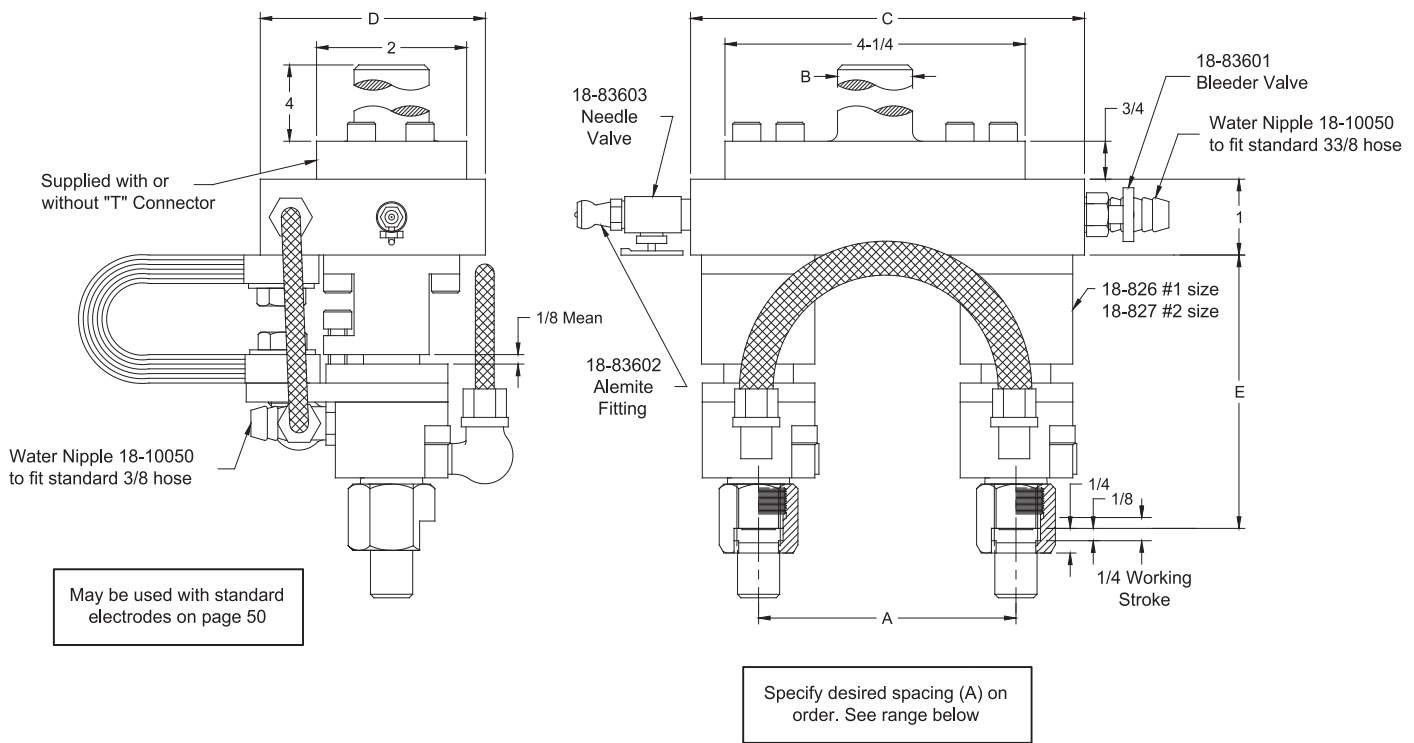

Assembly Unit Part No.	Unit Size	"T" Connector Shank Dia. B	Base Plate Length C	Base Plate Width D	Spacing* (Specify on Order) A	Max. Recommended Weld force Per Electrode LBS	Mean Height to Electrode Base E
18-846 18-84601-01	#1	None 1"	6	3	1-1/32" to 5"	1000 (12,000 Amps @ 10% duty cycle)	3-13/64
18-84601-02 18-84601-03		1-1/4" 1-1/2"					
18-847 18-84701-01	#2	None 1"	7-1/2	3-1/2	1-3/4" to 6"	2000 (16,000 Amps @ 10% duty cycle)	3-61/64
18-84701-02 18-84701-03		1-1/4" 1-1/2"					

Note:

- Multiple units of 2-8 can also be supplied on custom designed base plates with or without "T" Connectors.
- Units may be modified with adapters for RW tapered caps and electrodes

Contact Factory
All above items
priced and made
to special order.

ADJUSTABLE HYDRAULIC EQUALIZING ASSEMBLY 18-836



Phone: 800-521-3722

Fax: 864-877-2212

Email: cmw@cmwinc.com

ADJUSTABLE HYDRAULIC EQUALIZING ASSEMBLY 18-836

Part No. 18-836 (shown below) is a typical assembly using two 18-826 assemblies set up as a complete self-contained unit for making two spot welds at one time. This unit is so arranged as to allow the center distances to be readily adjusted from 1-3/32" centers to 2-1/4" centers or by rearrangement of the same parts centers may be adjusted from 2-1/4" to 3-1/2". This setup also include facilities for filling and bleeding the hydraulic units. "T" Mounting 18-83614 is available to order for assembly 18-836. We recommend using fire resistant hydraulic fluid compatible with BUNA "N" such as HOUGHTO-SAFE #620, 1120 or equivalent. Consult your local industrial lubricant distributor.

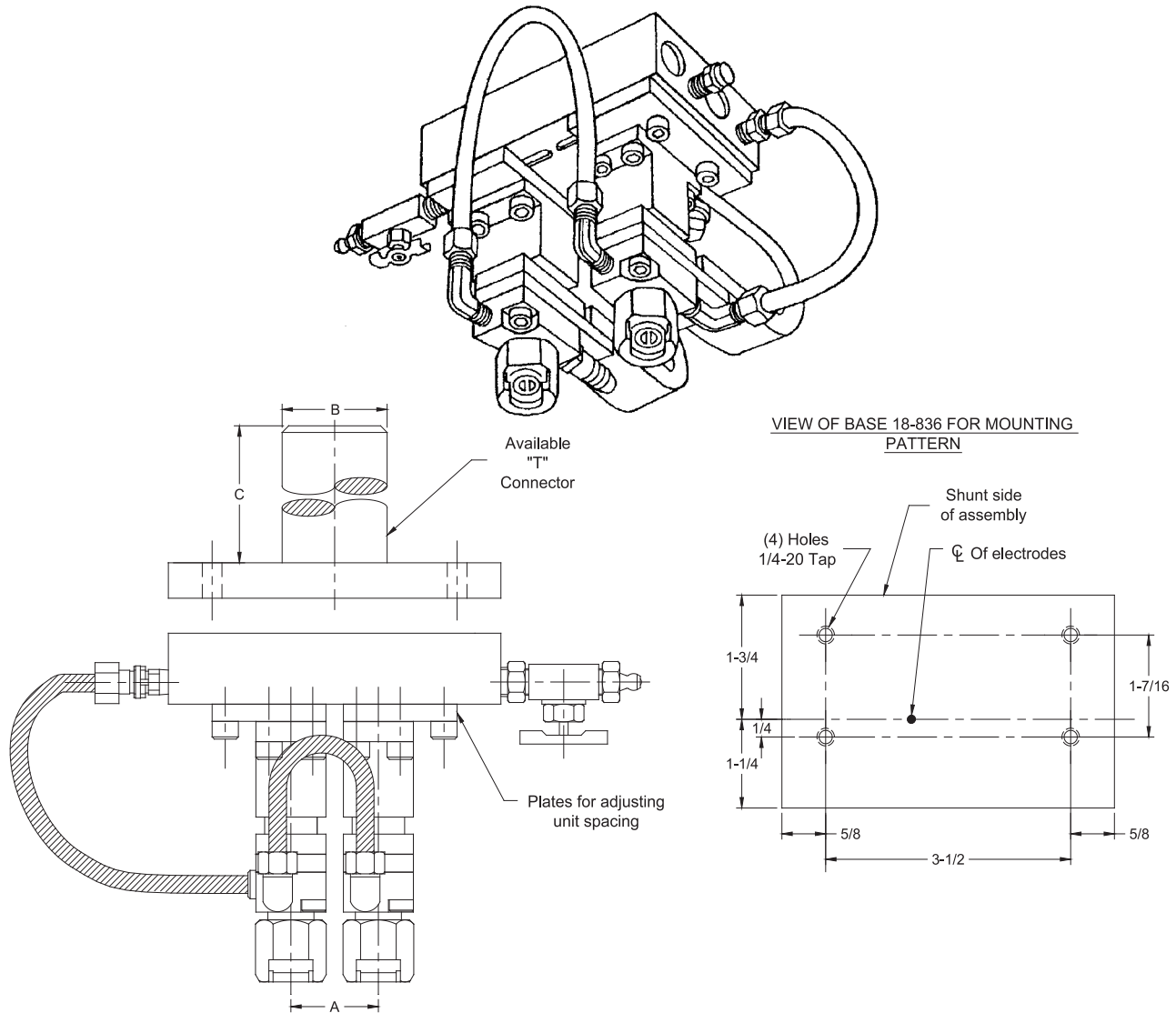

Assembly Part No.	Hydraulic Unit Size	Electrode Attachment ***	Adjustable Spacing Range A	"T" Connector	Max. Recommended Weld force Per Electrode LBS
18-836	#1	#1 NU-TWIST ^o	1-1/32 - 2-1/4 2-1/4 - 3-1/2*	NONE	1000 (12000 AMPS @ 10% Duty Cycle)

Available	Dia. B	Length C
18-83614-01	**	4
18-83614-03	**	**

* Partial disassembly, rearrangement of plates, and bleeding of unit will be necessary to switch centerline ranges.

** Customer must specify dimensions desired.

*** Other attachments available on request

Contact Factory
All above items
priced and made
to special order.

CMW HYDRAULIC EQUALIZING ADAPTERS AND ASSEMBLIES

Phone: 800-521-3722

Fax: 864-877-2212

Email: cmw@cmwinc.com

HYDRAULIC EQUALIZING ADAPTERS AND ASSEMBLIES

CMW Hydraulic Equalizing adapter units are used to equalize the weld force when two or more welds are required simultaneously. The equalizing action is developed in a closed hydraulic system - and is accomplished by hydraulically interconnecting two or more units. We recommend using fire resistant hydraulic fluid compatible with BUNA "N" such as HOUGHTO-SAFE #620, 1120 or equivalent. Consult your local industrial lubricant distributor.

18-826 #1 SIZE UNIT WITH NU-TWIST® SHOWN

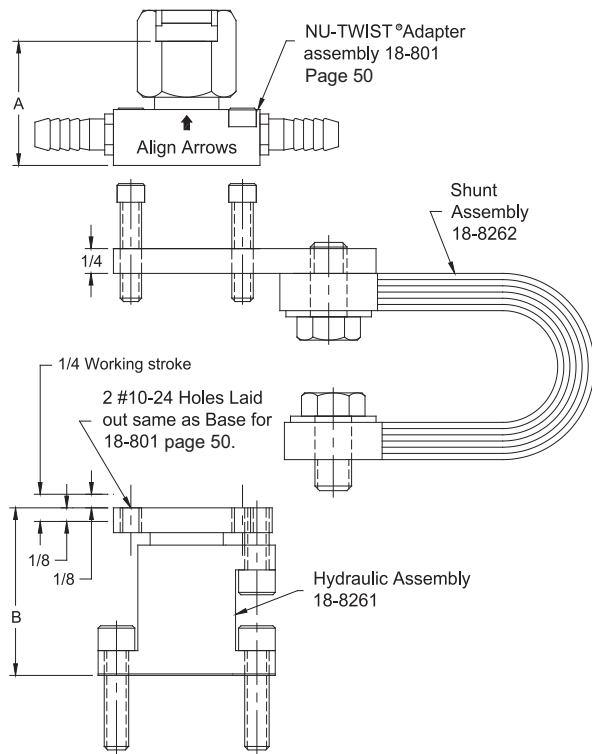
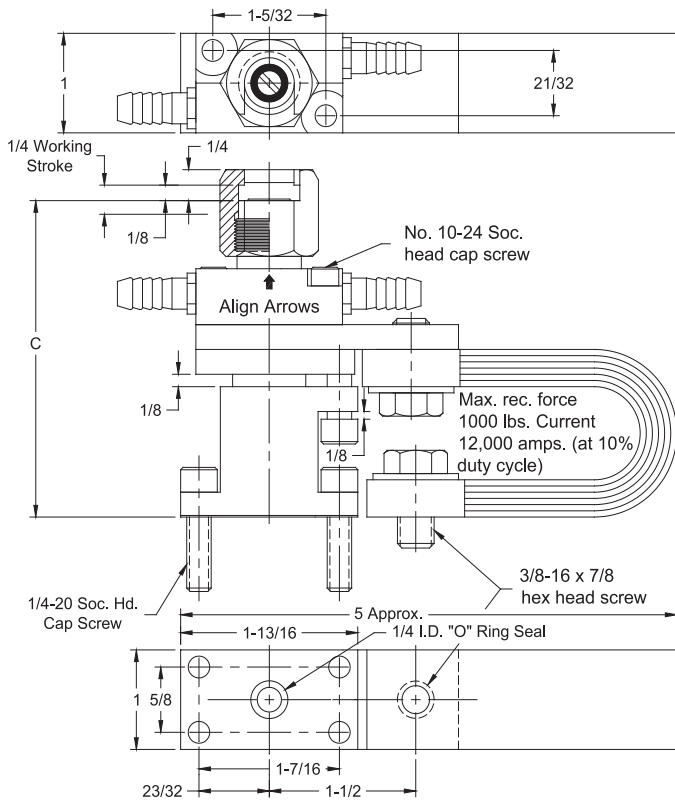

Complete Unit Part No.	Unit Size.	Electrode Attachment	Included Tapered Adapters	Height A	Mean Height B	Mean Electrode Engagement Height C
18-826	#1	NU-TWIST®	--	1-1/4		3-13/64
18-82650	#1	1/2-14 Pipe Thd.	--	1-1/2		3-29/64
18-82651	#1 with adapters	5 RW Male cap	18-7465-07	1-59/64	1-43/64	3-7/8
18-82652		4 RW	18-746-07	1-51/64		3-3/4
18-82653		5 RW	18-747-07	1-51/64		3-3/4

*037-0108 Rebuild Kit for Hydraulic Equalizers

Contact Factory
All above items
priced and made
to special order.

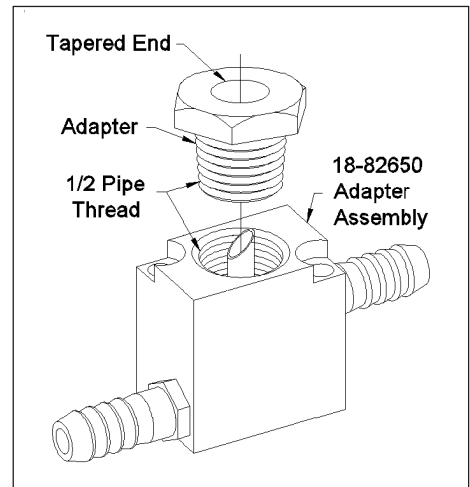

HYDRAULIC EQUALIZING ADAPTERS AND ASSEMBLY REPLACEMENT PARTS



Phone: 800-521-3722

Fax: 864-877-2212

Email: cmw@cmwinc.com

HYDRAULIC EQUALIZING ADAPTERS AND ASSEMBLIES

18-826 COMPLETE #1 SIZE "NU-TWIST"® ASSEMBLY

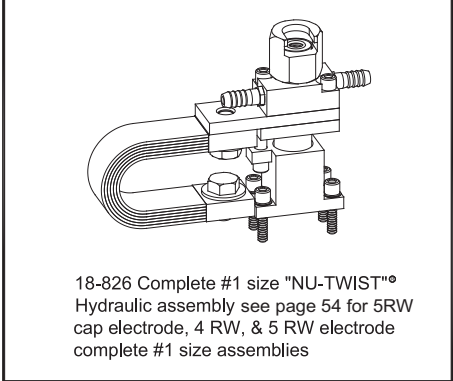
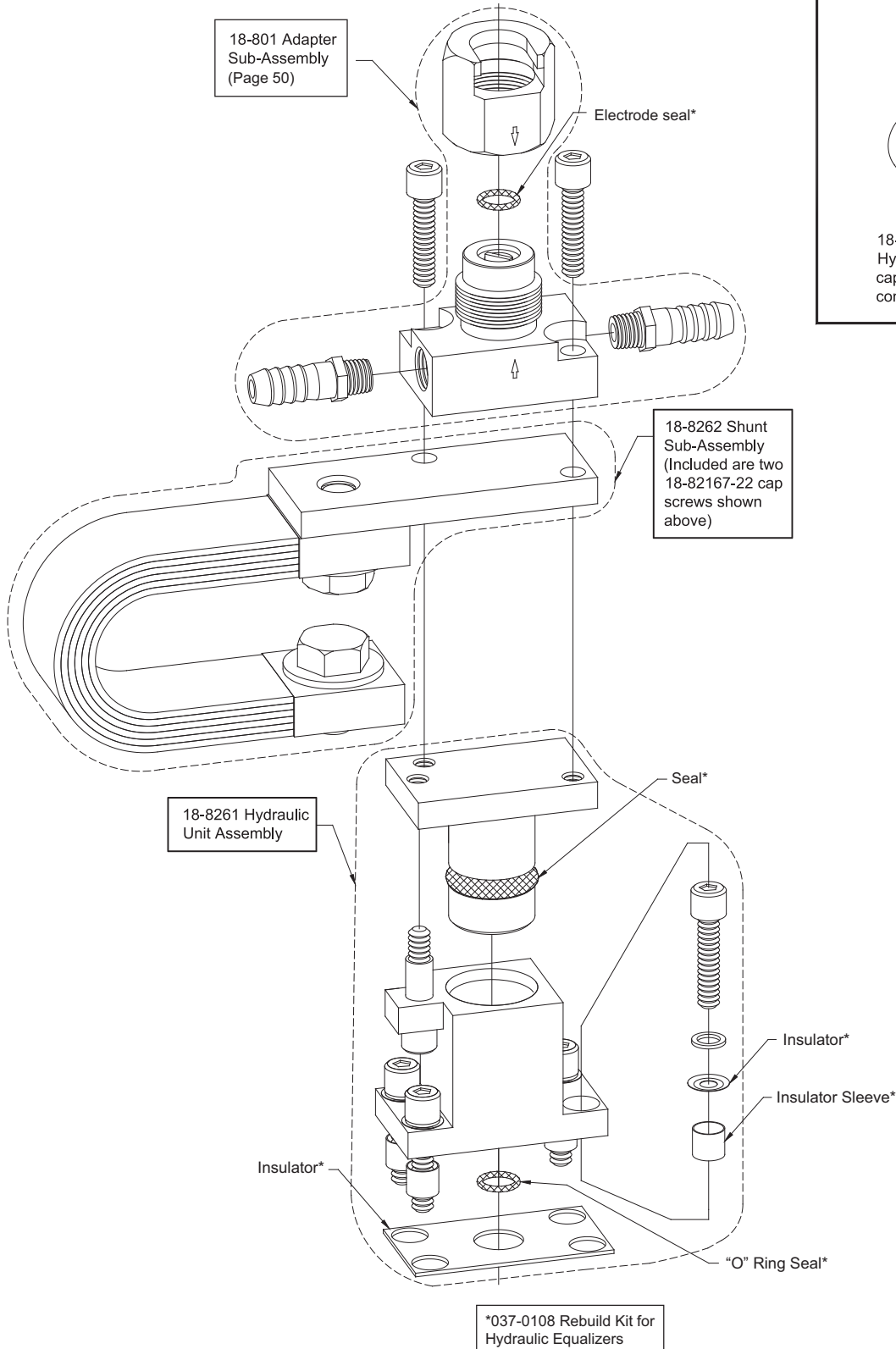

18-826 Complete #1 size "NU-TWIST"® Hydraulic assembly see page 54 for 5RW cap electrode, 4 RW, & 5 RW electrode complete #1 size assemblies

Contact Factory
All above items
priced and made
to special order.

CMW HYDRAULIC EQUALIZING ADAPTERS AND ASSEMBLIES

Phone: 800-521-3722

Fax: 864-877-2212

Email: cmw@cmwinc.com

HYDRAULIC EQUALIZING ADAPTERS AND ASSEMBLIES

CMW Hydraulic Equalizing adapter units are used to equalize the weld force when two or more welds are required simultaneously. The equalizing action is developed in a closed hydraulic system - and is accomplished by hydraulically interconnecting two or more units. We recommend using fire resistant hydraulic fluid compatible with BUNA "N" such as HOUGHTO-SAFE #620, 1120 or equivalent. Consult your local industrial lubricant distributor.

18-827 #2 SIZE UNIT WITH "NU-TWIST"® SHOWN

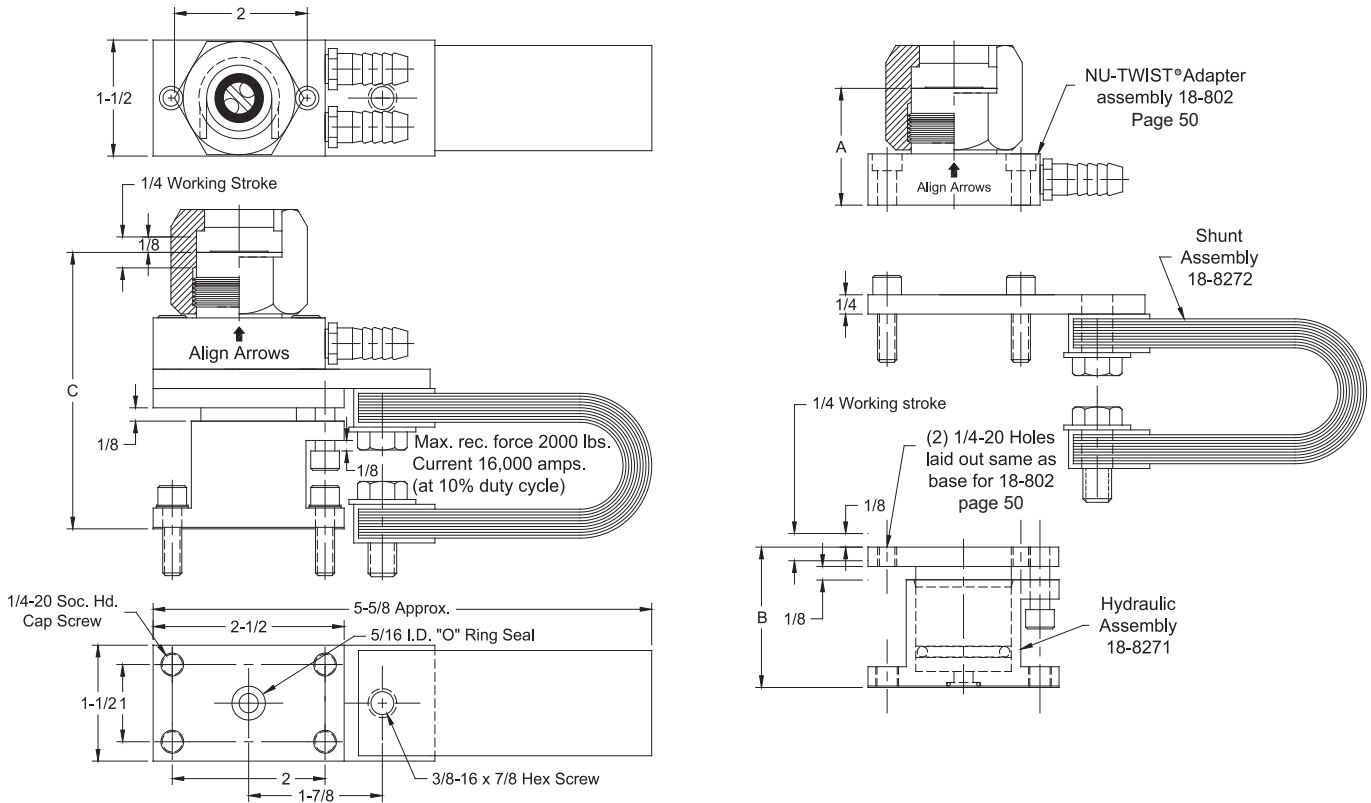

Complete Unit Part No.	Unit Size.	Electrode Attachment	Height A	Mean Height B	Mean Electrode Base Height C
18-827	#2	NU-TWIST	1-13/16	1-49/64	3-53/64

*037-0108 Rebuild Kit for Hydraulic Equalizers

Contact Factory
All above items
priced and made
to special order.

HYDRAULIC EQUALIZING ADAPTERS AND ASSEMBLY REPLACEMENT PARTS



Phone: 800-521-3722

Fax: 864-877-2212

Email: cmw@cmwinc.com

HYDRAULIC EQUALIZING ADAPTERS AND ASSEMBLIES

18-827 COMPLETE #2 SIZE "NU-TWIST" ASSEMBLY

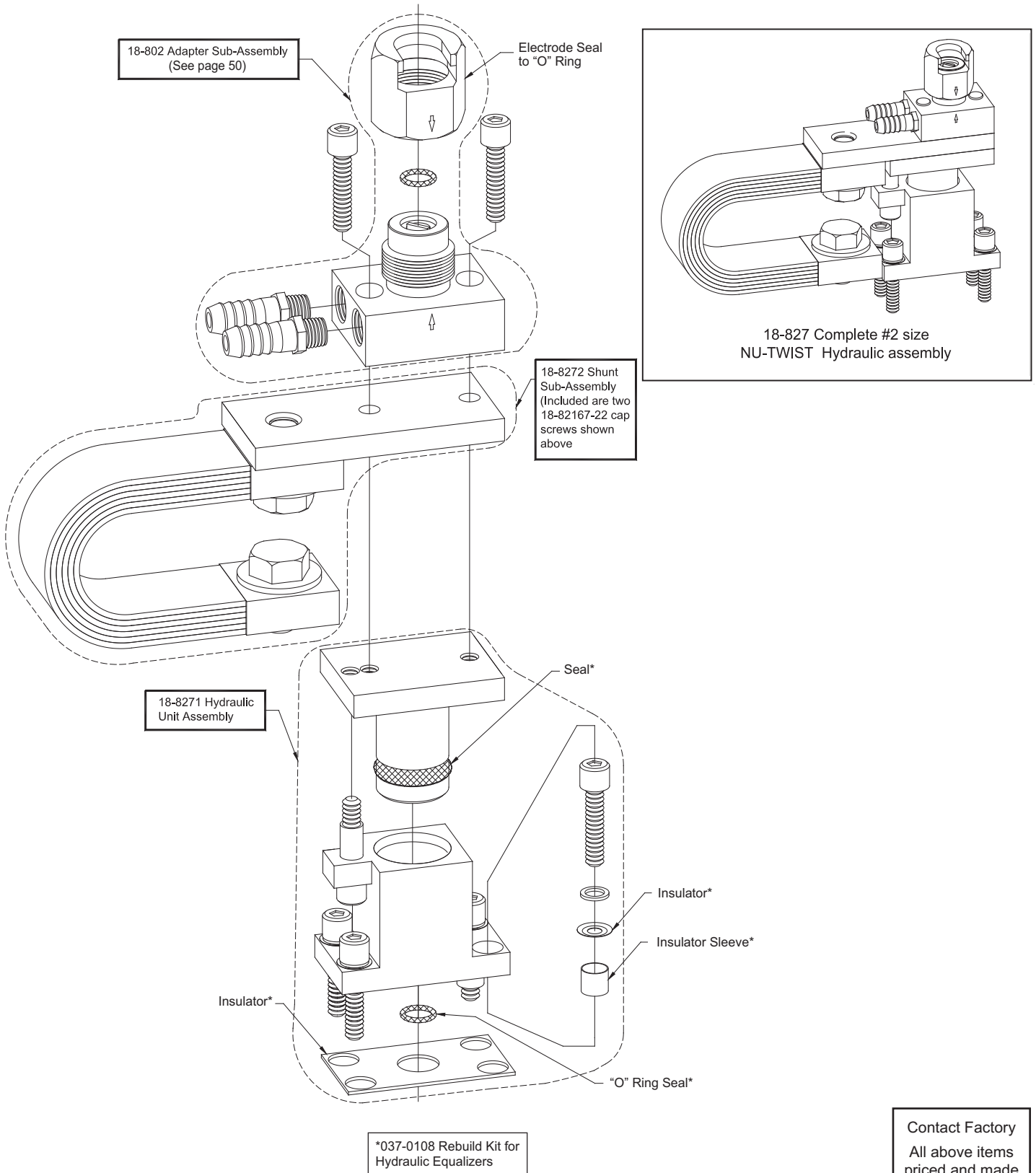

Contact Factory
All above items
priced and made
to special order.

1100 SERIES ADJUST-A-PRESSURE WATER COOLED LOW INERTIA ELECTRODE HOLDER

Phone: 800-521-3722

Fax: 864-877-2212

Email: cmw@cmwinc.com

1100 SERIES ADJUST-A-PRESSURE WATER COOLED LOW INERTIA ELECTRODE HOLDERS

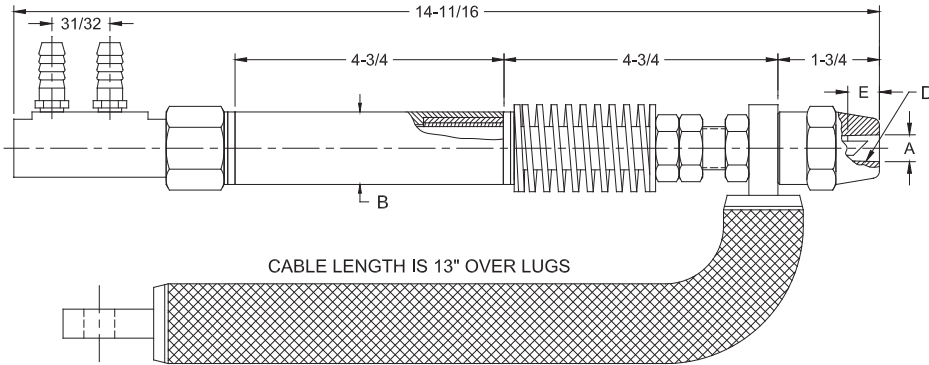

Like other low-inertia holders the heavy duty Adjust-A-Pressure Holders are used for multiple spot and projection welding, and are excellent for indirect welding when mounted in the Adjust-A-Angle Adapter.

Electrical current is conducted through heavy flexible cables and holder is installed to prevent any damaging effects to the spring mechanism. Light duty springs supplied to order.

Part No. Holder Assy.*	Major Taper Dia. A	Barrel Dia. B	Taper D	Standard Electrode Taper Engagement E	Pressure Range (Pounds)
18-1101	.463	1-1/4	4 RW	1/2	to 500
18-1102	.625		5 RW	3/4	
18-1103	.463	1-1/2	4 RW	1/2	
18-1104	.625		5 RW	3/4	

* Standard holder uses 18-110006-1 spring. A heavy duty holder is available with spring 18-110006-2 for pressure to 1000 lbs.

For additional holder information and replacement parts see page 59.

1150 SERIES ADJUST-A-ANGLE ADAPTERS

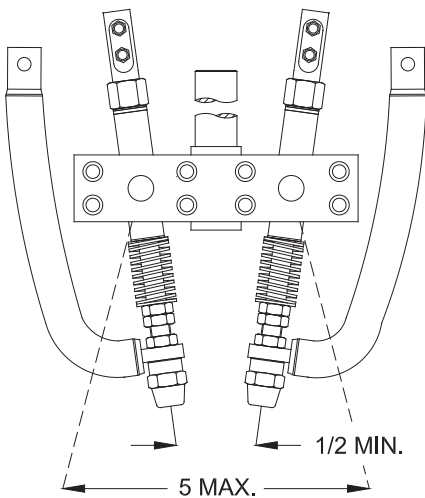

1100 SERIES HOLDERS ASSEMBLED IN 1150 SERIES ADAPTER

1150 SERIES ADJUST-A-ANGLE ADAPTERS ARE ADAPTABLE FOR USE WITH SPRING TYPE LOW INERTIA HOLDERS 1100 SERIES AS WELL AS STRAIGHT HOLDERS 100, 200, AND 300 SERIES.

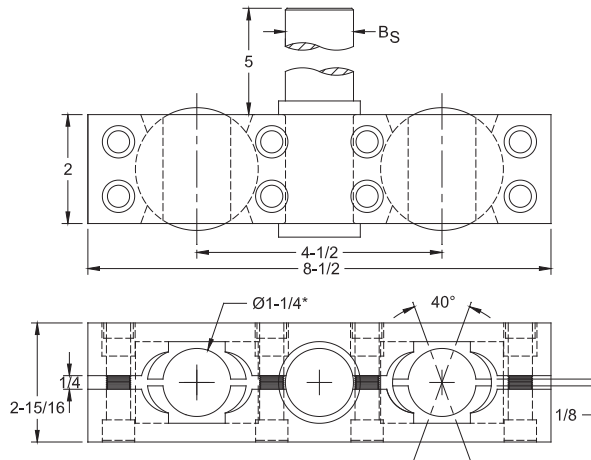

Adapter Assembly Part No.*	Shank Dia. BS
18-1154	1
18-1155	1-1/4
18-1156	1-1/2

* Adapters for all barrel sizes are available as specials

1100 SERIES ADJUST-A-PRESSURE HOLDER REPLACEMENT PARTS



Phone: 800-521-3722

Fax: 864-877-2212

Email: cmw@cmwinc.com

1100 SERIES ADJUST-A-PRESSURE WATER COOLED LOW INERTIA ELECTRODE HOLDERS

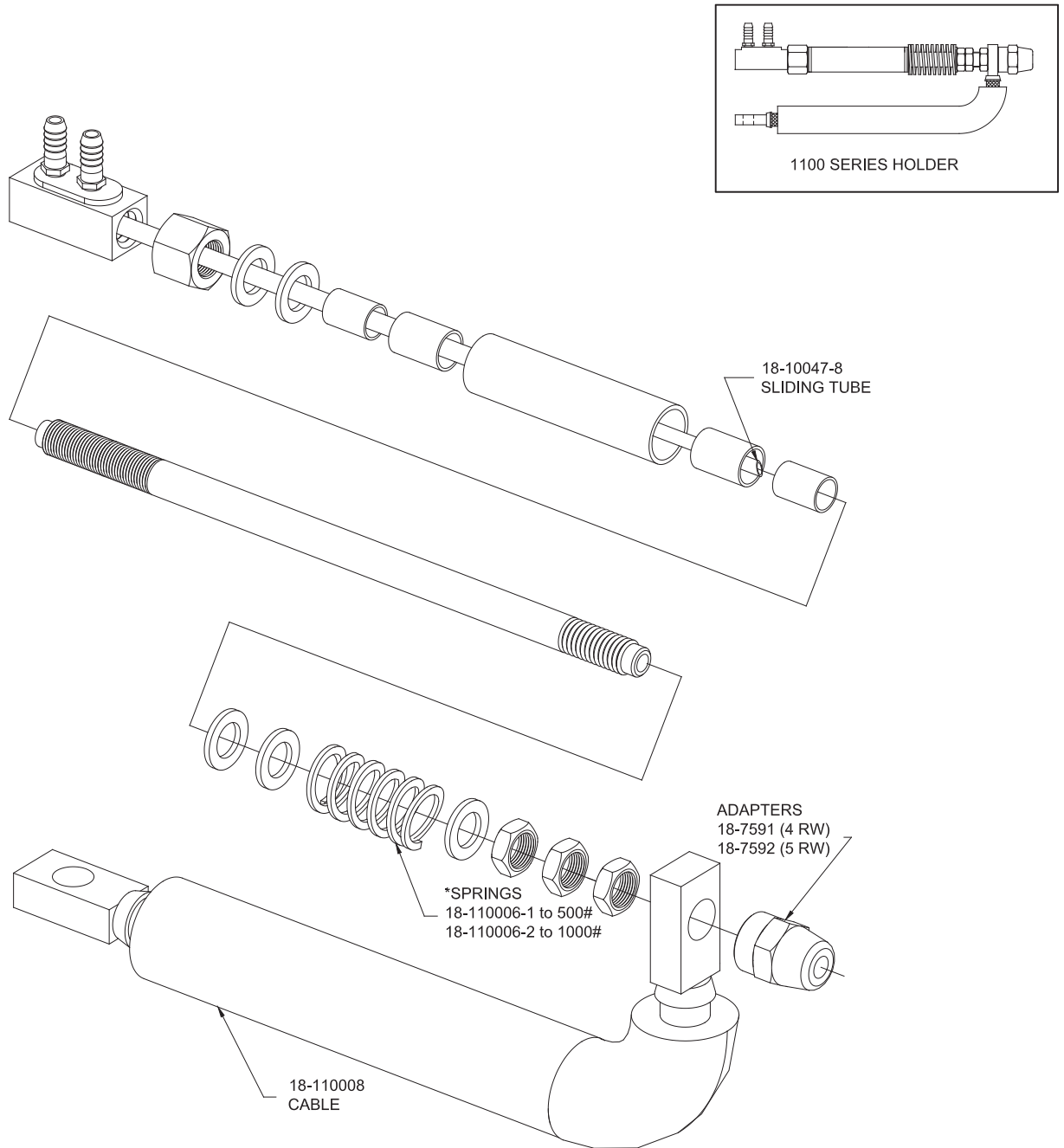

* SPRINGS: 500# SPRING IS PAINTED BLUE; 1000# SPRING IS PAINTED YELLOW

Part No. Holder Assy.*	Barrel	Adapter	Adjust -A- Angle Adapters
18-1101 18-1102	18-110005-1	18-7591 18-7592	Select from 1150 Series Chart page 58
18-1103 18-1104	18-110005-2	18-7591 18-7592	Special order

* See page 58 for more information

APPLICATION SHEET FOR TYPICAL MULTIPLE SPOT WELDING SETUPS



Phone: 800-521-3722

Fax: 864-877-2212

Email: cmw@cmwinc.com

APPLICATION SHEET FOR TYPICAL MULTIPLE SPOT WELDING SETUPS

Typical Set Up For
3 Spots at a time in Parallel

- 1 CMW Std. 1150 Series Adapter
- 2 CMW Std. 1100 Series Holders
- 1 CMW Special 1100 Series Holder

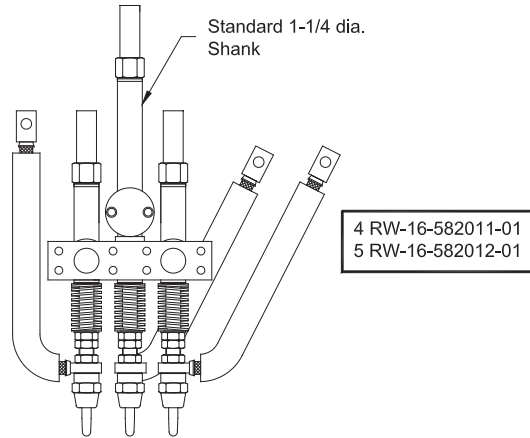

Typical Set Up For
2 spots simultaneously
in parallel

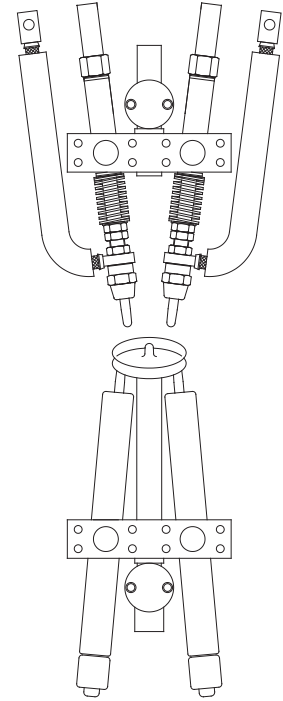

- Upper
- 2-1100 Series Holders
- 1-1150 Series Adapter

- Lower
- 2-100,200 or 300 Series Holders
- 1-1150 Series Adapter with special center shank

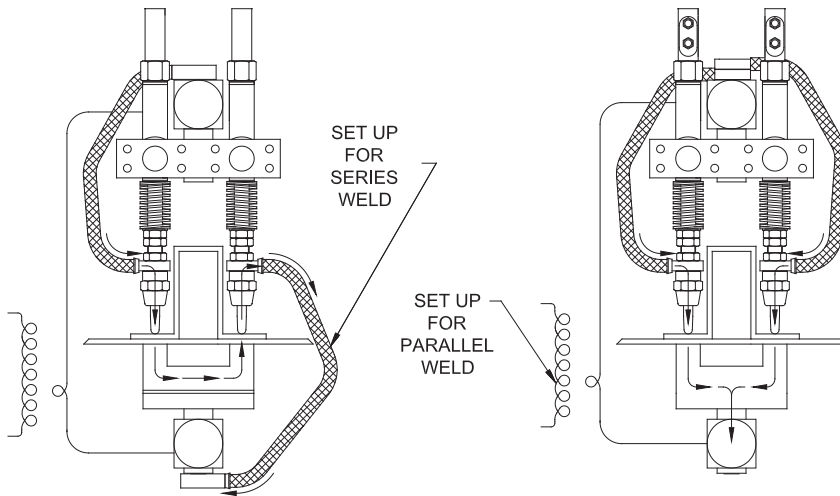

Contact Factory
All above items
priced and made
to special order
Illustrations
only

TYPICAL SET UP OF 800 SERIES "NU-TWIST"® UNITS

For dual spot welding using hydraulic "Nu-Twist"® Pressure equalizing subassemblies and surface mounted adapters as basic building blocks

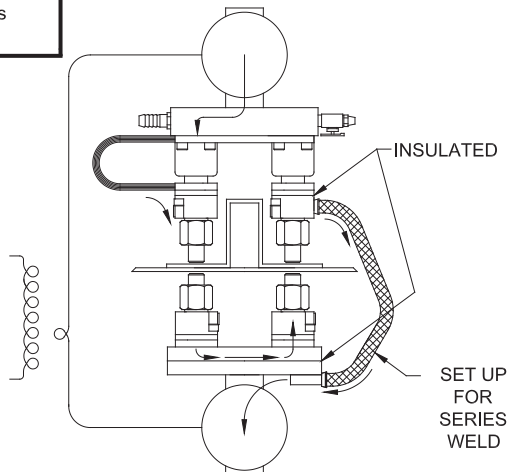

- Upper
- two
- 18-826
- hydraulic
- unit assemblies
- mounted on
- fixed centers
- (See Pages
- 52 & 53)

- Lower
- two
- 18-801
- surface
- mounted
- "Nu-Twist"®
- Adapters
- (See page 50)

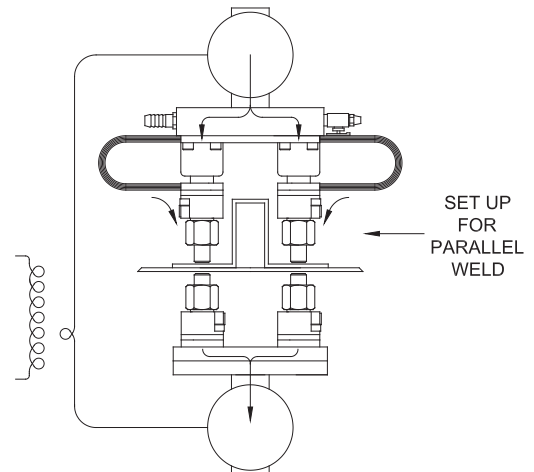

MULTI-SPOT WELDER ELECTRODE ADAPTERS



Phone: 800-521-3722

Fax: 864-877-2212

Email: cmw@cmwinc.com

MULTI-SPOT WELDER ELECTRODE ADAPTERS

CMW electrode adapters for multispot air or hydraulic pistons are supplied with 3/4 diameter straight piston rod ends. These adapters are equipped with means for attaching the welding cable from the transformer and the water hoses to the inlet and outlet water connections.

These adapters are available in four basic assemblies as shown in the table.

MULTI-SPOT WELDER ELECTRODE ADAPTER REPLACEMENT PARTS

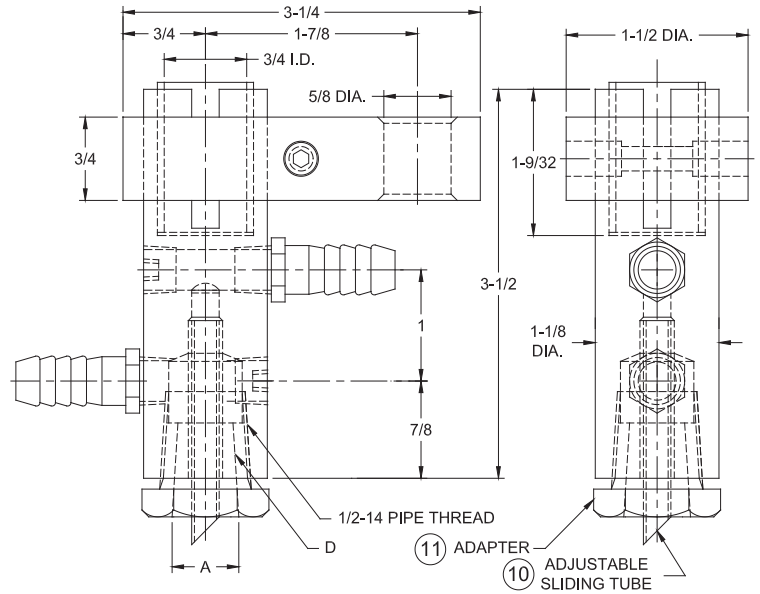
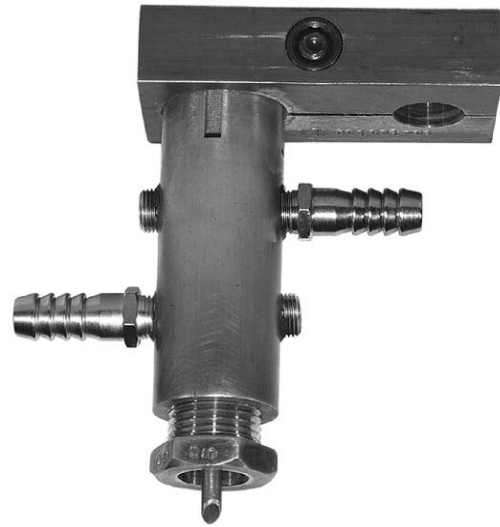
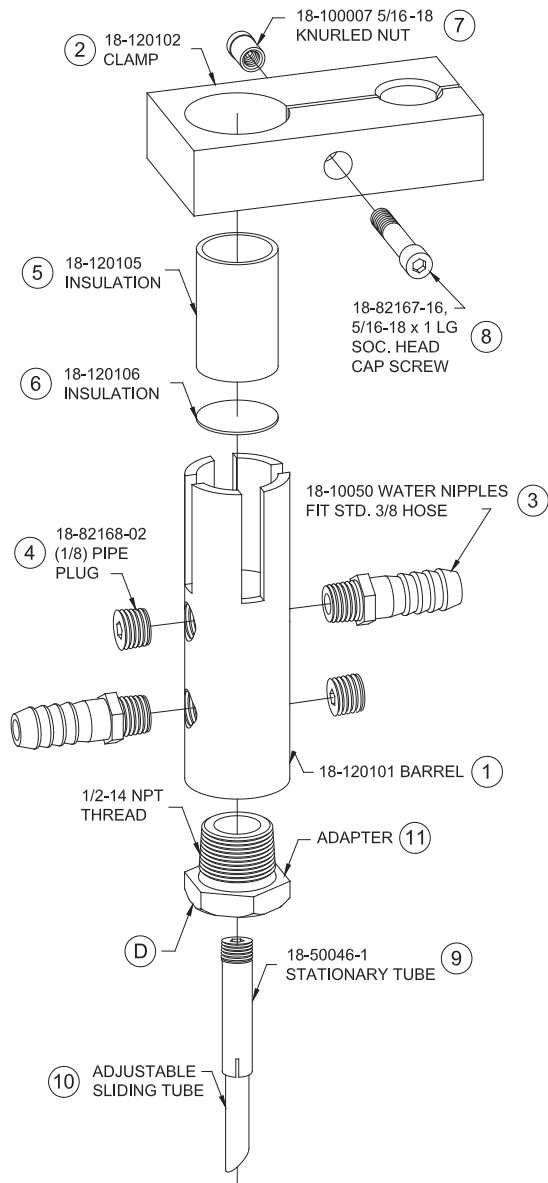

Part No. Assembly	Major Tape Dia. A	Attachment Type D	Adjustable Sliding tube 10	Adapter Part No. 11*
18-1201	--	1/2-14 NPT	18-10046-23	--
18-1202	.414	5 RW Male cap	--	18-7465-07
18-1203	.463	4 RW	18-10046-23	18-746-07
18-1204	.625	5 RW	18-10046-23	18-747-07

All assemblies include items 1, 2, 3, 4, 5, 6, 7, 8, and 9.

* See page 31 for adapter details.



SHUNTS AND JUMPERS

Phone: 800-521-3722

Fax: 864-877-2212

Email: cmw@cmwinc.com

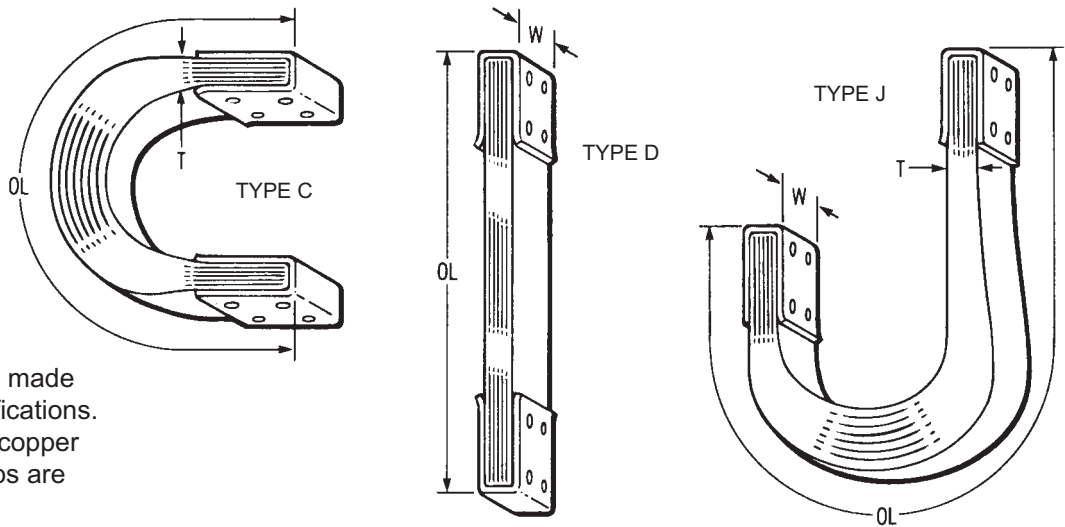

Laminated copper shunts are made to your size and shape specifications. High conductivity electrolytic copper strip is used, and terminal clips are riveted in place.

HOW TO ORDER

Give the following information:

Type (C, F, or J)

Outside length (OL)

Width (W)

Thickness (less clip) (T)

Hole pattern (specify by letter code)

Hole location (X, Y, Z values)

Hole diameter

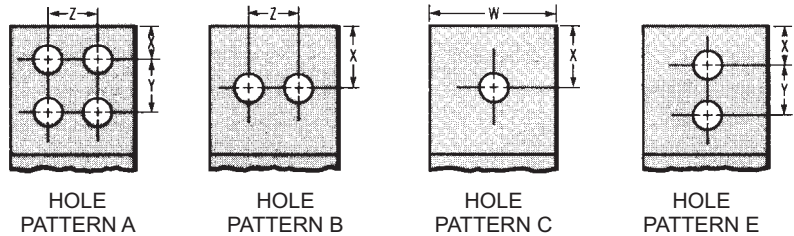

Air-cooled jumper cables are flexible, high-conductivity copper conductors with insulative sleeves. They are made in lengths to suit your needs.

HOW TO ORDER

Give the following information:

Conductor rating (MCM)

Length between holes

Terminal orientation style

TERMINAL ORIENTATION

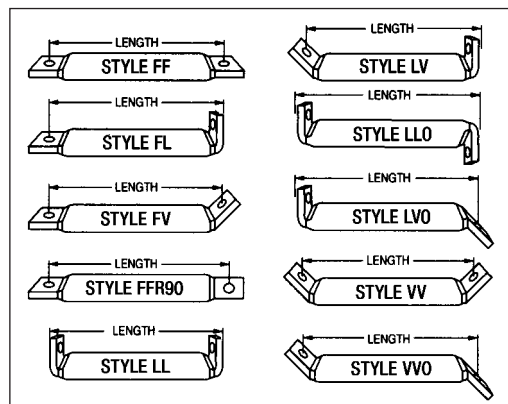

DIMENSIONS, INCHES

MCM Rating	O.D. (approx.)	Lug Width A	Lug Thickness B
600	1-5/8	1-3/8	.50
750	1-3/4	1-3/8	.60
1000	2	1-1/2	.70
1200	2-1/8	1-1/2	.82
1500	2-1/4	1-1/2	.99

Holes are 17/32 unless otherwise specified.

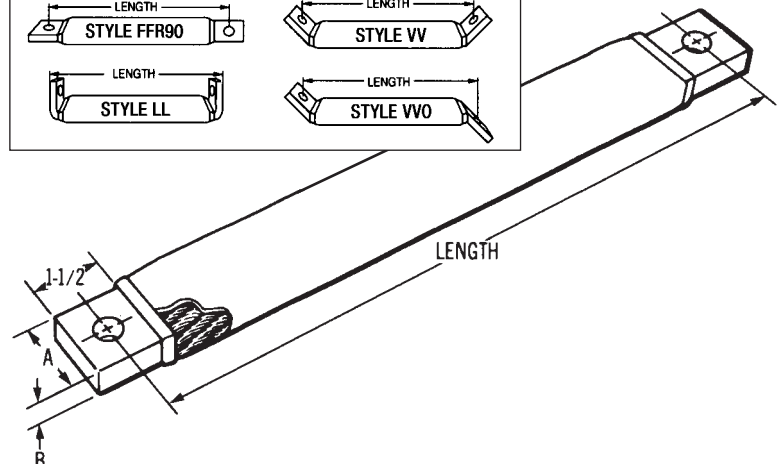



Phone: 800-521-3722

Fax: 864-877-2212

Email: cmw@cmwinc.com

TIP SOCKET REAMERS & TAP

Hole in reamer center permits water tube entry; no need to dismantle holder. 4 RW; Part No. 601-0004; 5 RW, Part No. 601-0005; 6 RW, Part No. 601-0006; 7 RW, Part No. 601-0007.
5/8-14 NPT Tap, Part No. 601-0025



MALE CAP SOCKET REAMERS

To ream or dress sockets to hold male caps. 4 RW, Part No. 601-0014; 5 RW, Part No. 601-0015; 6 RW, Part No. 601-0016.

TIP DRESSING TOOL



To remove mushroomed nose material on a pair of tips of 4 or 5 RW size, having pointed or dome noses. Dresser, Part No. 601-0102; Dresser cutter, Part No. 601-0103.

RADIUS TIP FILE



Tip File

To restore original contours of welding tips use this two-inch radius file. File, Part No. 601-0120; Handle, Part No. 601-0120-H; File & Handle, Part No. 601-0120-A.

WELDING TIP EXTRACTORS



No. 4 RW and 5 RW at opposite ends, EX-3, Part No. 601-0203



No. 4 RW, EX-1, Part No. 601-0201
No. 5 RW, EX-2, Part No. 601-0202



Standard Duty: EX-10-A, Part No. 601-0231
Heavy Duty: SW-250, Part No. 601-SW-250

QUICK-CONNECT COUPLINGS with automatic shut-off

Use these couplings to make up efficient, trouble free coolant systems. Any plug shown will mate with any socket shown. Always put the socket on the upstream side of a connection. Its built-in valve will automatically close upon disconnection.



1/8" NPT female plug
Part No. 601-0300

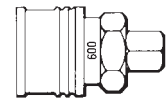

1/8" NPT female socket
Part No. 601-0314

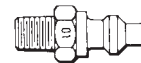

1/8" NPT male plug
Part No. 601-0301

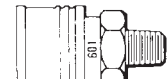

1/8" NPT male socket
Part No. 601-0315

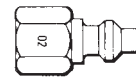

1/4" NPT male plug
Part No. 601-0302

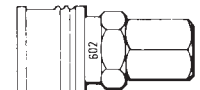

1/4" NPT female socket
Part No. 601-0316

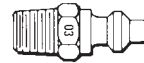

1/4" NPT male plug
Part No. 601-0303

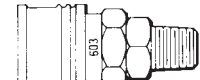

1/4" NPT male socket
Part No. 601-0317



3/8" NPT hose plug
Part No. 601-0309

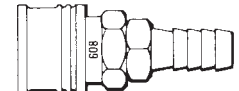

3/8" NPT hose socket
Part No. 601-0320

CONDUCTIVE LUBE

Part No. 601-0400
1 lb. container

WATER HOSE

Part No. 601-0350
3/8 ID

HOSE CLAMP

Part No. 601-0340

MALE CAP EXTRACTORS

Male Caps, 4 & 5 RW, EX-45, Part No. 601-0240
Male Caps, 5 & 6 RW, EX-56, Part No. 601-0242



Male cap extractor has long lever handles for easier cap removal. In two dual-size models: EX-45 and EX-56.

Female Caps, 4 RW, EX-4F, Part No. 601-0220
Female Caps, 5 RW, EX-5F, Part No. 601-0221
Female Caps, 6 RW, EX-6F, Part No. 601-0222

Male Cap 4 RW
Male Cap 5 & 6 RW
Male Cap 7 RW

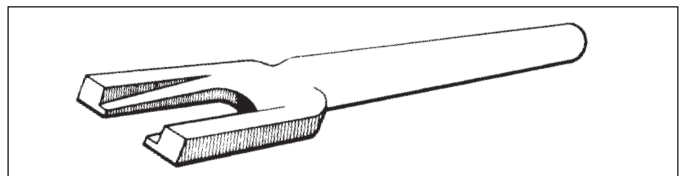

Female cap extractors are made for three cap shank sizes: Models EX-4F, EX-5F, and EX-6F.



WA2 WELD ANALYZER

Phone: 800-521-3722

Fax: 864-877-2212

Email: cmw@cmwinc.com

WA2 WELD ANALYZER

- Current meter
- Easy to use
- Easily legible in all lighting conditions
- Positive keypad action
- Suitable for various applications
- Reads wave forms from 50 Hz upwards
- Traceable accuracy
- Data archiving
- Small and lightweight allowing for easy portability
- Calibration services available
- One year warranty



FEATURES

- Intuitive, flexible interface
- LCD 128 x 64 pixels FSTN with yellow/green backlight
- Embossed disc tactile keypad with antiglare display window
- Auto power-off
- Large choice of coils
- AC or MFDC operation
- Calibration certification
- USB connection
- Includes 6 inch flexible coil, batteries and carrying case
- Integrator output for oscilloscope connection
- WA Terminal software

OPTIONS

- Flexible coil – 3 inch (Part No. 313027) or 12 inch (Part No. 313021) diameter with 6.5 feet lead
- Attenuator – range multiplier for up to 300kA (Part No. 316009)
- Extension cable – 10 meters (Part No. 316010)



PNEUMATIC POWER HANDLE ELECTRODE DRESSER PART NO. 18-1310

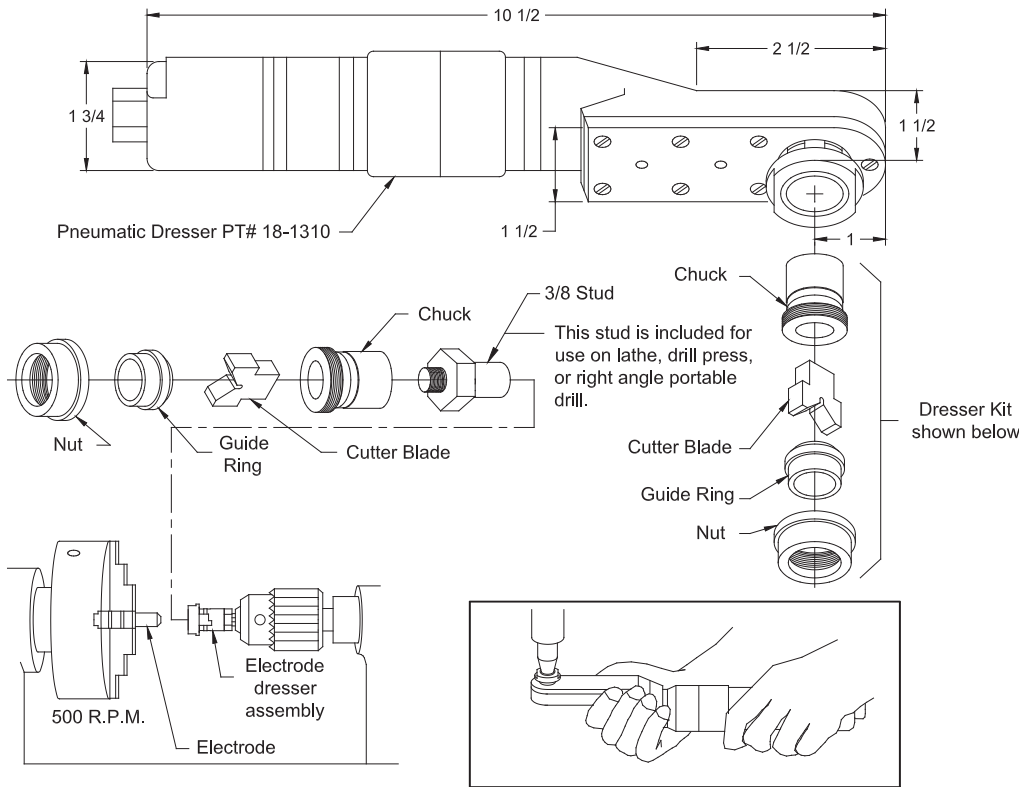

Light weight and rugged construction, this CMW Pneumatic Power Handle requires a clearance of only 1-1/2" with a standard ring and 2" with an extended ring. In most situations this allows dressing of electrodes without removal from the welder. Operating at a cutting speed of 1200 rpm, it enables the operator to dress electrodes quickly and accurately. Cutters and guide rings are easily replaced. These must be matched to the electrode nose and are selected from the chart below.

CMW Electrode Dresser 18-1310 is supplied without blade holder, ring, and cutter blade. When ordering, specify the "Kit" appropriate for your dressing needs as selected from the table below. "The stud" furnished with the kit is not required when using the Pneumatic Power Handle. It may optionally be used, but will increase the clearance required on the welder for dressing. Additional special cutters can be furnished upon special request.

These kits may also be used for cap electrode dressing.

Size To Dress									
4 RW .482 Dia	Nose style CMW Electrode No.	Dome x11x..	Pointed x21x..	Flat x31x..	2" Radius x51x..	3" Radius x81x..	4" Radius x91x..	10" Radius x61x..	Truncated x71x..
	Kit to Order**	18-1390411	18-1390420	18-1390410	18-1390413	18-1390414	18-1390415	18-1390416	18-1390412
	Replacement Blade Replacement Guide Ring (Each for above kit)	18-139411 18-139401	18-139420 18-139402	18-139410 18-139401	18-139413 18-139401	18-139414 18-139401	18-139415 18-139401	18-139416 18-139401	18-139412 18-139401
5 RW .625 Dia	CMW Electrode No.	x12x..	x22x..	x32x..	x52x..	x82x..	x92x..	x62x..	x72x..
	Kit to Order**	18-1390511	18-1390520	18-1390510	18-1390513	18-1390514	18-1390515	18-1390516	18-1390512
	Replacement Blade Replacement Guide Ring (Each for above kit)	18-139511 18-139501	18-139520 18-139502	18-139510 18-139501	18-139513 18-139501	18-139514 18-139501	18-139515 18-139501	18-139516 18-139501	18-139512 18-139501

** Note: This kit includes Stud for (for 3/8 Keyed Chuck), Chuck, 1 Guide Ring, 1 Appropriate blade, and Retaining Nut.

Note: Cutters are **NOT** designed to conform to "Electrode Cap" geometries. Caps are intended for value salvage when expended.



WELD FORCE GAUGES

Phone: 800-521-3722

Fax: 864-877-2212

Email: cmw@cmwinc.com

HIGH-ACCURACY WELD FORCE GAUGES

Digital-Electronic



DLC Gauge



Digital-Hydraulic



Standard-Hydraulic



WE OFFER ONE OF THE BROADEST PRODUCT LINES AVAILABLE TODAY

CMW supplies a broad range of weld force gauges, available with accuracies from 0.5% for Digital-Electronic gauges; to 2% accuracy for the Digital-Hydraulic which has a digital output driven by hydraulics; to our Standard Hydraulic models with 2%-3% accuracy. All are available in English and metric readouts.

Our **Digital-Electronic** gauge supplies the highest accuracy (0.5% for 95% of the gauges range). The gauge has large LCD readouts with peak-hold capabilities. All functions are electronic which prevents variations caused by flexing.

The **Digital-Hydraulic** delivers better accuracy than standard hydraulic gauges but at a lower price than all-digital models. The unit of measure is field selectable between pounds, kilograms, newtons and kilonewtons. The peak-hold feature allows for reading variable forces, which are common in resistance welding machinery. Gauges maintain an accuracy of 2% for 30% to 90% of the gauge's range.





CMW's **Standard Hydraulic** gauges are the low cost method for obtaining general force measurements. These gauges are available in a standard block style, with extensions. Sizes range from 600 lb. up to 10 tons with accuracy of 2% at the mean and 3% outside of mean for 70% of the gauge's range.

STANDARD GAUGE DATA

Description	Features	Item Number
Gauge Case 	<ul style="list-style-type: none"> • Convenient padded gauge storage/carrying case • 4" D x 10" W x 10" L • Fits all hydraulic gauges 	601-8019



STANDARD GAUGE DATA

Description	Features	Maximum Reading	Increment Every	Opening Required	Extension Length	Item Number
Digital-Electronic Weld Probe 	<ul style="list-style-type: none"> • <i>Analog output</i> • <i>Auto shut-off</i> • <i>No-weld setting-not required</i> • <i>Accuracy 0.5% over full range</i> 	0-1000 lbs/ 0-454 Kg	1 lb 1 Kg	1/4"	10"	601-8010MD 601-8045MD-KG
		0-3000 lbs/ 0-1360 Kg	1 lb 1 Kg	1/2"	10"	601-8300MD 601-8136MD-KG
		0-5000 lbs/ 0-2270 Kg	1 lb 1 Kg	1.1"	10"	601-8500MD 601-8227MD-KG
		0-10,000 lbs/ 0-4540 Kg	1 lb 1 Kg	1.1"	10"	601-8100MD 601-8453MD-KG
DLC Digital-Electric 	<ul style="list-style-type: none"> • <i>Accuracy 0.50%</i> • <i>NIST traceable certification</i> • <i>Response time less than 500 ms</i> • <i>Field selectable units switch between: Pounds Kilograms Newtons Kilonewtons</i> • <i>Peak hold feature</i> 	3000 lb 1363 Kg 13344 N 13.34 KN	1 lb 1 Kg 1 N 0.01 KN	9/16"	—	601-3000DLC
		5000 lb 2272 Kg 2224 N 22.24 KN	1 lb 1 Kg 1 N 0.01 KN	9/16 "	—	601-5000DLC
Digital-Hydraulic* 	<ul style="list-style-type: none"> • <i>Accuracy 2%</i> • <i>NIST traceable certification</i> • <i>Field selectable units switch between: Pounds Kilograms Newtons Kilonewtons</i> 	0-3000 lbs. 0-1360 Kg 0-13,300 N	1 lb 1 Kg 1 N	3/4"	—	601-3000DR
		0-5000 lbs 0-2270 Kg 0-22,200 N	1 lb 1 Kg 1 N	3/4"	—	601-5000DR
		0-10,000 lbs 0-4540 Kg 0-44,500 N	1 lb 1 Kg 1 N	3/4"	—	601-9999DR
		0-3000 lbs 0-1360 Kg 0-13,300 N	1 lb 1 Kg 1 N	3/4"	12"	601-3000DR-12S
Standard-Hydraulic* 	<ul style="list-style-type: none"> • <i>Accuracy 3%</i> 	0-600 lbs	10 lb	3/4"	—	601-8006
		0-1000 lbs	20 lb	3/4"	—	601-8010
		0-2000 lbs	50 lb	3/4"	—	601-8020
		0-2000 lbs	50 lb	3/4"	12"	601-8020-12
		0-3000 lbs	20 lb	3/4"	—	601-8030
		0-3000 lbs	20 lb	3/4"	12"	601-8030-12
		0-5000 lbs	100 lb	3/4"	—	601-5000
		0-6000 lbs	50 lb	3/4"	—	601-6000
		0-6000 lbs	50 lb	3/4"	18"	601-6000-18
		0-10,000 lbs	100 lb	3/4"	—	601-8100
		0-5000 Kg	50 Kg	3/4"	—	601-8101

* Hydraulic gauges should be selected to be used near mid-range.



APPLICATION DATA SHEET

Phone: 800-521-3722

Fax: 864-877-2212

Email: cmw@cmwinc.com

SPOT WELDING DATA

OPTIMUM CONDITIONS

SCHEDULES FOR SPOT WELDING LOW CARBON STEEL—SAE 1010

Thick- ness of Thinnest Outside Piece (Inches)	Electrode Diameters and Shape*			Recommended Minimum Standard Electrode Size	Weld Force (Lbs.)	Weld Time (Cycles) (60 Cycles per Sec.)	Hold Time (Cycles) Min.	Welding Current (Amps.) (Approx.)	Weld Shear Strength (For Steels Having Ultimate Tensile Strength of 90,000 psi and below) Minimum Strength (Lbs/Weld)	Diameter of Fused Zone (Approx.) Dw (Inches)	Minimum Weld Spacing S (Inches)	Minimum Contacting Overlap L (Inches)
	Flat Face		Radius Face									
	Maximum d (Inches)	Min. D (Inches)	Radius R (Inches)									
0.010	0.125	1/2	2	4RW 1MT	160	4	5	4,000	130	0.113	1/4	3/8
0.021	0.187	1/2	2	4RW 1MT	244	6	8	6,500	300	0.139	3/8	7/16
0.031	0.187	1/2	2	4RW 1MT	326	8	10	8,000	530	0.161	1/2	7/16
0.040	0.250	5/8	3	5RW 2MT	412	10	12	8,800	812	0.181	3/4	1/2
0.050	0.250	5/8	3	5RW 2MT	554	14	16	9,600	1,195	0.210	7/8	9/16
0.062	0.250	5/8	3	5RW 2MT	670	18	20	10,600	1,717	0.231	1	5/8
0.078	0.312	5/8	3	5RW 2MT	903	25	30	11,800	2,365	0.268	1-1/8	11/16
0.094	0.312	5/8	4	7RW 3MT	1,160	34	35	13,000	3,054	0.304	1-1/4	3/4
0.109	0.375	7/8	4	7RW 3MT	1,440	45	40	14,200	3,672	0.338	1-5/16	13/16
0.125	0.375	7/8	4	7RW 3MT	1,760	60	45	15,600	4,300	0.375	1-1/2	7/8
0.156	0.500	7/8	6	Male or Female Threaded	2,500	93	50	18,000	6,500	0.446	1-3/4	1
0.187	0.625	1	6	Male or Female Threaded	3,340	130	55	20,500	9,000	0.516	2	1-1/2
0.250	0.750	1-1/4	6	Male or Female Threaded	5,560	230	60	26,000	18,000	0.660	4	1-1/2

PERMISSIBLE SCHEDULE VARIATIONS FOR SPOT WELDING LOW CARBON STEEL

Low Carbon Steel Spot Welding Data Chart—Single Impulse Welding

DATA COMMON TO ALL CLASSES OF SPOT WELDS			WELDING SET-UP FOR BEST QUALITY—CLASS A WELDS						WELDING SET-UP FOR MEDIUM QUALITY—CLASS B WELDS						WELDING SET-UP FOR GOOD QUALITY—CLASS C WELDS					
Thick- ness of Each of the Two Work Pieces (Inches)	Electrode Diam. & Shape		Min. Weld Spacing (Note 4) (Inches)	Min. Con- tacting Overlap (Note 6) (Inches)	Weld Time (Note 7) (Cycles)	Elec- trode Force (Pounds)	Weld- ing Cur- rent (Amps.)	Diam. of Fused Zone Dw (Inches)	Average Tensile Shear Strength ±14% (Pounds)	Weld Time (Note 7) (Cycles)	Elec- trode Force (Pounds)	Weld- ing Cur- rent (Amps.)	Diam. of Fused Zone Dw (Inches)	Average Tensile Shear Strength ±17% (Pounds)	Weld Time (Note 7) (Cycles)	Elec- trode Force (Pounds)	Weld- ing Cur- rent (Amps.)	Diam. of Fused Zone Dw (Inches)	Average Tensile Shear Strength ±20% (Pounds)	
	Min. D (Inches)	Max. d (Inches)																		
.010	1/2	1/8	1/4	3/8	4	200	4000	.13	235	5	130	3700	.12	200	15	65	3000	.11	160	
.021	1/2	3/16	3/8	7/16	6	300	6100	.17	530	10	200	5100	.16	460	22	100	3800	.14	390	
.031	1/2	3/16	1/2	7/16	8	400	8000	.21	980	15	275	6300	.20	850	29	135	4700	.18	790	
.040	5/8	1/4	3/4	1/2	10	500	9200	.23	1305	21	360	7500	.22	1230	38	180	5600	.21	1180	
.050	5/8	1/4	7/8	9/16	12	650	10300	.25	1820	24	410	8000	.23	1700	42	205	6100	.22	1600	
.062	5/8	1/4	1	5/8	14	800	11600	.27	2350	29	500	9000	.26	2150	48	250	6800	.25	2050	
.078	5/8	5/16	1-1/8	11/16	21	1100	13300	.31	3225	36	650	10400	.30	3025	58	325	7900	.28	2900	
.094	5/8	5/16	1-1/4	3/4	25	1300	14700	.34	4100	44	790	11400	.33	3900	66	390	8800	.31	3750	
.109	7/8	3/8	1-5/16	13/16	29	1600	16100	.37	5300	50	960	12200	.36	5050	72	480	9500	.35	4850	
.125	7/8	3/8	1-1/2	7/8	30	1800	17500	.40	6900	60	1140	12900	.39	6500	78	570	10000	.37	6150	

NOTES:

- Low Carbon Steel as hot rolled, pickled, and slightly oiled with an ultimate strength of 42,000 to 45,000 PSI Similar to SAE 1005—SAE 1010.
- Electrode Material is CLASS 2
- Surface of steel is lightly oiled but free from grease, scale or dirt.
- Minimum weld spacing is that distance for which no increase in welding current is necessary to compensate for the shunted current effect in adjacent welds.
- Radius Face electrodes may be used:
0.010 to 0.031 — 2" Radius
0.031 to 0.078 — 3" Radius
0.078 to 0.125 — 4" Radius
-
- Weld time is indicated in cycles of 60 cycle frequency.
- Tensile shear strength values are based on recommended test sample sizes:
Direction of Force:

Thickness	Width	Length
.000" to .029"	5/8"	3"
.030" to .058"	1"	4"
.059" to .115"	1-1/2"	5"
.116" to .190"	2"	6"
- Tolerance for machining of electrode diameter "d" is ±.015" of specified dimension.
- Electrode force does not provide for force to press ill-fitting parts together.

For Additional Welding Information Go To www.HowToResistanceWeld.org



PROJECTION WELDING DATA

DESIGN AND WELDING DATA FOR PROJECTION WELDING LOW CARBON STEELS

Thickness of Thinnest Outside Piece Inches	PROJECTION DESIGN		ELECTRODE DIAMETERS (d=2 x Projection Diameter)		Electrode Force Pounds	Weld Time (Cycles) 60 Cycles per Sec.	Hold Time (Cycles) Minimum	Welding Current Amperes (Approx.)	Diameter of Fused Zone Dw Inches	Minimum Shear Strength (Single Projection) Pounds	Minimum Contacting Overlap L Inches
	Base Diameter of Projection Dp Inches	Height of Projection H Inches	Minimum d Inches	Minimum D Inches							
0.010	0.055	0.015	0.125	1/2	50	3	3	2,800	0.112	150	1/8
0.012	0.055	0.015	0.125	1/2	80	3	3	3,100	0.112	200	1/8
0.014	0.055	0.015	0.125	1/2	100	3	3	3,400	0.112	250	1/8
0.016	0.067	0.017	0.187	1/2	115	4	4	3,600	0.112	285	5/32
0.021	0.067	0.017	0.187	1/2	150	6	6	4,000	0.140	380	5/32
0.025	0.081	0.020	0.187	1/2	200	6	8	4,500	0.140	525	3/16
0.031	0.094	0.022	0.187	1/2	300	8	8	5,100	0.169	740	7/32
0.034	0.094	0.022	0.187	1/2	350	10	10	5,400	0.169	900	7/32
0.044	0.119	0.028	0.250	5/8	480	13	14	6,500	0.169	1,080	9/32
0.050	0.119	0.028	0.250	5/8	580	16	16	7,100	0.225	1,500	9/32
0.062	0.156	0.035	0.312	7/8	750	21	20	8,400	0.225	2,100	3/8
0.070	0.156	0.035	0.312	7/8	900	24	24	9,200	0.281	2,550	3/8
0.078	0.187	0.041	0.375	7/8	1,050	26	30	10,500	0.281	2,950	7/16
0.094	0.218	0.048	0.500	7/8	1,300	32	30	11,800	0.281	3,700	1/2
0.109	0.250	0.054	0.500	7/8	1,650	38	36	13,300	0.338	4,500	5/8
0.125	0.281	0.060	0.500	7/8	1,800	45	40	15,000	0.338	5,200	11/16
0.140	0.312	0.066	0.625	1	2,300	60	45	15,700	0.437	6,000	3/4
0.156	0.343	0.072	0.625	1	2,800	80	50	17,250	0.500	7,500	13/16
0.171	0.375	0.078	0.750	1	3,300	105	50	18,600	0.562	8,500	7/8
0.187	0.406	0.085	0.750	1	3,800	125	50	20,000	0.562	10,000	15/16
0.203	0.437	0.091	0.875	1-1/4	4,500	145	55	21,500	0.625	12,000	1
0.250	0.531	0.110	1.000	1-1/4	6,600	230	60	26,000	0.687	15,000	1-1/4

NOTES:

- Type of Steel—Low Carbon SAE 1010—0.15% Carbon Maximum.
- Material free of scale, oxide, paint, dirt, etc.
- Size of projection determined by thickness of thinnest piece and projection should be on thickest piece.
- Data is based on thickness of thinnest sheet for two thicknesses only. Maximum ratio between two thicknesses = 3 to 1.
- See TABLE BELOW for design of punch and die for making projections.
- Contacting overlap does not include any radii from forming.
- Projection should be located in center of overlap.
- Tolerance for Projection Dimensions:

Dimension	Thickness Up to 0.050"	Thickness Over 0.050"
Diameter "D"	±0.003"	±0.007"
Height "H"	±0.002"	±0.005"

9. Electrode Material:
CLASS 3 RWMA CLASS 11 - 10W

From American Welding Society "Recommended Practices for Resistance Welding"

PUNCH AND DIE DESIGN FOR FORMING WELDING PROJECTIONS

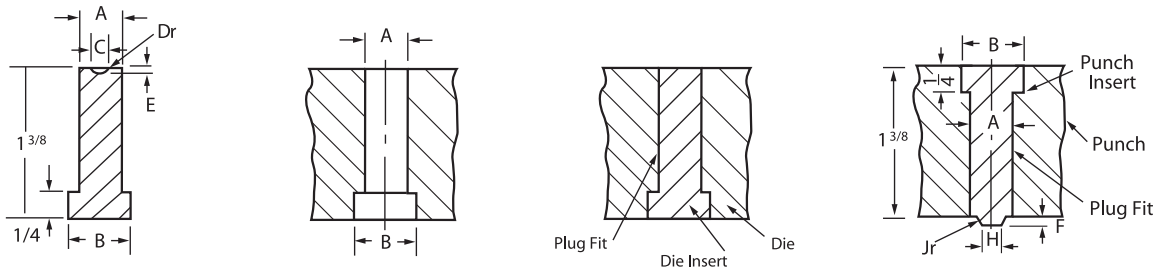

Mat Thickness	Pt. No.	A	B	±.002 C	Dr	±.001 E	±.001 F	±.001 H	Jr
0.010-0.015	1	3/8	9/16	.055	.033	.015	.015	.035	.005
0.016-0.021	2	3/8	9/16	.067	.042	.017	.020	.039	.005
.025	3	3/8	9/16	.081	.050	.020	.025	.044	.005
.031	4	3/8	9/16	.094	.062	.022	.030	.050	.005
.034	5	3/8	9/16	.094	.062	.022	.030	.050	.005
.044	6	3/8	9/16	.119	.078	.028	.035	.062	.005
.050	7	3/8	9/16	.119	.078	.028	.035	.062	.005
.062	8	3/8	9/16	.156	.105	.035	.043	.081	.005
.070	9	3/8	9/16	.156	.105	.035	.043	.081	.005
.078	10	3/8	9/16	.187	.128	.041	.055	.104	.010

Mat Thickness	Pt. No.	A	B	±.002 C	Dr	±.001 E	±.001 F	±.001 H	Jr
.094	11	1/2	11/16	.218	.148	.048	.065	.115	.010
.109	12	1/2	11/16	.250	.172	.054	.075	.137	1/64
.125	13	1/2	11/16	.281	.193	.060	.085	.154	1/64
.140	14	1/2	11/16	.312	.217	.066	.096	.172	1/64
.156	15	5/8	13/16	.343	.243	.072	.107	.191	1/64
.171	16	5/8	13/16	.375	.265	.078	.118	.210	1/64
.187	17	5/8	13/16	.406	.285	.085	.130	.229	1/64
.203	18	11/16	7/8	.437	.308	.091	.143	.240	.020
.250	19	13/16	1	.531	.375	.110	.175	.285	.025

Material: Tool Steel. Finish all over and harden to 65-68 Rockwell "C" scale. Note: All working surfaces of die unit must be polished. From American Welding Society "Recommended Practices for Resistance Welding"

For Additional Welding Information Go To www.HowToResistanceWeld.org





APPLICATION DATA SHEET

Phone: 800-521-3722

Fax: 864-877-2212

Email: cmw@cmwinc.com

SCHEDULE FOR SPOT WELDING STAINLESS STEEL

THICKNESS "T" OF THINNEST OUTSIDE PIECE (See Notes 1, 2, 3 and 4 Below)	ELECTRODE DIAMETER AND SHAPE (See Note 5)		ELECTRODE FORCE LB.	WELD TIME CYCLES (60 Per Sec.)	WELDING CURRENT (Approx.) AMPS		MINIMUM CONTACTING OVERLAP 	MINIMUM WELD SPACING (See Note 6 Below) 	DIAMETER OF FUSED ZONE 	MINIMUM SHEAR STRENGTH LB.		
	D, IN., Min.	d, IN., Max.			Tensile Strength Below 150000 Psi	Tensile Strength 150000 Psi and Higher				Ultimate Tensile Strength of Metal		
										70000 Up to 90000 Psi	90000 Up to 150000 Psi	150000 Psi and Higher
0.006	3/16	3/32	180	2	2000	2000	3/16	3/16	0.045	60	70	85
0.008	3/16	3/32	200	3	2000	2000	3/16	3/16	0.065	150	170	210
0.012	1/4	1/8	260	3	2100	2000	1/4	1/4	0.076	185	210	250
0.014	1/4	1/8	300	4	2500	2200	1/4	1/4	0.082	240	250	320
0.016	1/4	1/8	330	4	3000	2500	1/4	5/16	0.088	280	300	380
0.018	1/4	1/8	380	4	3500	2800	1/4	5/16	0.093	320	360	470
0.021	1/4	5/32	400	4	4000	3200	5/16	5/16	0.100	370	470	500
0.025	3/8	5/32	520	5	5000	4100	3/8	7/16	0.120	500	600	680
0.031	3/8	3/16	650	5	6000	4800	3/8	1/2	0.130	680	800	930
0.034	3/8	3/16	750	6	7000	5500	7/16	9/16	0.150	800	920	1100
0.040	3/8	3/16	900	6	7800	6300	7/16	5/8	0.160	1000	1270	1400
0.044	3/8	3/16	1000	8	8700	7000	7/16	11/16	0.180	1200	1450	1700
0.050	1/2	1/4	1200	8	9500	7500	1/2	3/4	0.190	1450	1700	2000
0.056	1/2	1/4	1350	10	10300	8300	9/16	7/8	0.210	1700	2000	2450
0.062	1/2	1/4	1500	10	11000	9000	5/8	1	0.220	1950	2400	2900
0.070	5/8	1/4	1700	12	12300	10000	5/8	1-1/8	0.250	2400	2800	3550
0.078	5/8	5/16	1900	14	14000	11000	11/16	1-1/4	0.275	2700	3400	4000
0.094	5/8	5/16	2400	16	15700	12700	3/4	1-1/2	0.290	3550	4200	5300
0.109	3/4	3/8	2800	18	17700	14000	13/16	1-1/2	0.290	4200	5000	6400
0.125	3/4	3/8	3300	20	18000	15500	7/8	2	0.300	5000	6000	7600

NOTES:

- Types of Steel—301, 302, 303, 304, 308, 309, 310, 316, 317, 321, 347 & 349
- Material should be free from scale, oxides, paint, grease and oil.
- Welding conditions determined by thickness of thinnest outside piece "T."
- Data for total thickness of pile-up not exceeding 4 "T". Maximum ratio between two thicknesses 3 to 1.
- Electrode Material, CLASS 2, CLASS 3 or RWMA CLASS 11 - 10W
- Minimum weld spacing is that spacing for two pieces for which no special precautions need be taken to compensate for shunted current effect of adjacent welds. For three pieces increase spacing 30 per cent.

SCHEDULE FOR SEAM WELDING STAINLESS STEEL

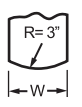
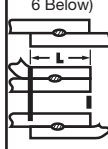
THICKNESS "T" OF THINNEST OUTSIDE PIECE (See Notes 1, 2, 3 and 4 Below)	ELECTRODE WIDTH AND SHAPE (See Note 5 Below) 	ELECTRODE FORCE LB.	ON TIME CYCLES (60 Per Sec.)	OFF TIME FOR MAXIMUM SPEED (Pressure-Tight) CYCLES		MAXIMUM WELD SPEED		WELDS PER INCH		WELDING CURRENT (Approx.) AMPS.	MINIMUM CONTACTING OVERLAP (See Note 6 Below) 	
				W, IN., Min.	2 "T"	4 "T"	IN. PER MINUTE		PER INCH			
							2 "T"	4 "T"	2 "T"			4 "T"
0.006	3/16	300	2	1	1	60	67	20	18	4000	1/4	
0.008	3/16	350	2	2	2	67	56	18	16	4600	1/4	
0.010	3/16	400	3	2	2	45	51	16	14	5000	1/4	
0.012	1/4	450	3	2	2	48	55	15	13	5600	5/16	
0.014	1/4	500	3	2	3	51	46	14	13	6200	5/16	
0.016	1/4	600	3	2	3	51	50	14	12	6700	5/16	
0.018	1/4	650	3	2	3	55	50	13	12	7300	5/16	
0.021	1/4	700	3	2	3	55	55	13	11	7900	3/8	
0.025	3/8	850	3	3	4	50	47	12	11	9200	7/16	
0.031	3/8	1000	3	3	4	50	47	12	11	10600	7/16	
0.040	3/8	1300	3	4	5	47	45	11	10	13000	1/2	
0.050	1/2	1600	4	4	5	45	44	10	9	14200	5/8	
0.062	1/2	1850	4	5	7	40	41	10	8	15100	5/8	
0.070	5/8	2150	4	5	7	44	41	9	8	15900	11/16	
0.078	5/8	2300	4	6	7	40	41	9	8	16500	11/16	
0.094	5/8	2550	5	6	7	36	38	9	8	16600	3/4	
0.109	3/4	2950	5	7	9	38	37	8	7	16800	13/16	
0.125	3/4	3300	6	6	8	38	37	8	7	17000	7/8	

NOTES:

- Types of Steel—301, 302, 303, 304, 308, 309, 310, 316, 317, 321, 347 & 349
- Material should be free from scale, oxides, paint, grease and oil.
- Welding conditions determined by thickness of thinnest outside piece "T."
- Data for total thickness of pile-up not exceeding 4 "T". Maximum ratio between two thicknesses 3 to 1.
- Electrode material, CLASS 3
- For large assemblies minimum contacting overlap indicated should be increased 30 per cent.

From American Welding Society "Recommended Practices for Resistance Welding"

For Additional Welding Information Go To www.HowToResistanceWeld.org



Spot welding galvanized low-carbon steel

Material Thickness	Electrode Diameter And Shape			Net Electrode Force	Welding Current (Approx.)	Weld Time	Weld Nugget Size	Minimum Tension-Shear Strength	Minimum Weld Spacing	Minimum Contacting Overlap												
											Inches	In.	In.	Deg.	Lb.	Amps.	Cycles	In.	Lb.	Inches	Inches	
notes 1, 2, & 3				note 4																		
												0.022	5/8	3/16	120	300	13000	8	0.15	550	5/8	5/8
												0.030	5/8	3/16	120	400	13000	10	0.16	1000	5/8	5/8
												0.036	5/8	1/4	120	500	13500	12	0.19	1180	3/4	5/8
												0.039	5/8	1/4	120	650	14000	13	0.21	1400	3/4	5/8
												0.052	5/8	1/4	120	725	14500	18	0.22	1700	7/8	11/16
												0.063	3/4	1/4	120	850	15500	22	0.24	2500	1-1/8	3/4
												0.078	3/4	5/16	120	1200	19000	24	0.28	3200	1-1/4	7/8
												0.093	3/4	3/8	120	1400	21000	30	0.34	4200	1-1/2	1
												0.108	7/8	3/8	120	1750	20000	37	0.40	5900	1-3/4	1-1/8
0.123	7/8	3/8	120	2000	20000	42	0.48	7200	2	1-1/8												

NOTES:

1. Material must be free from dirt, grease, paint etc. prior to welding, but may have light oil.
2. Two equal metal thicknesses of each gage.
3. Commercial coating weight is 1.25 oz. per square foot.
4. Electrode Material-RWMA Group A, Class 2.
5. Water Cooling: 2 gallons per minute.

Projections should be larger in diameter for galvanized than for uncoated material.

Projection welding galvanized low-carbon steel

Material Thickness	Electrode Diameter And Shape			Net Electrode Force	Welding Current (Approx.)	Weld Time	Weld Nugget Size	Minimum Tension-Shear Strength	Projection Size												
									Diameter	Height											
notes 1, 2, & 3				note 4				(For Single Projections Only)													
												0.039	5/8	3/8	250	10000	15	0.15	925	0.187	0.041
												0.063	5/8	7/16	400	11500	20	0.25	2050	0.218	0.048
												0.078	3/4	1/2	550	16000	25	0.25	2700	0.250	0.054
												0.093	3/4	1/2	750	16000	30	0.30	4300	0.250	0.054
												0.108	7/8	1/2	950	22000	33	0.31	4900	0.250	0.054

NOTES:

1. Material must be free from dirt, grease, paint etc. prior to welding, but may have light oil.
2. Two equal metal thicknesses of each gage.
3. Commercial coating weight is 1.25 oz. per square foot.
4. Electrode Material-RWMA Group A, Class 2.
5. Pressure-tight joints require stripping the zinc coating prior to welding.
6. Nominal electrode diameter ranges between 8 to 10 inches.

From American Welding Society "Recommended Practices for Resistance Welding."

Seam welding galvanized low-carbon steel

Material Thickness	Electrode Width And Shape			Net Electrode Force	Welding Current (Approx.)	Weld Time		Welding Speed	Welds Per Inch	Minimum Contacting Overlap										
						Heat Time	Cool Time													
notes 1, 2, & 3				note 4																
											0.015	3/8	1/4	900	15000	2	2	120	7.5	3/8
											0.036	1/2	1/4	1100	18000	4	2	60	10.0	1/2
											0.039	1/2	1/4	1200	19000	4	3	60	9.0	1/2
											0.052	1/2	1/4	1350	20000	5	1	90	7.0	9/16
											0.063	1/2	5/16	1500	19800	8	2	54	7.0	5/8
0.078	5/8	5/16	1850	23000	10	7	30	7.0	11/16											

For Additional Welding Information Go To www.HowToResistanceWeld.org



GCAP® WELD AND STEPPER SCHEDULE

Phone: 800-521-3722

Fax: 864-877-2212

Email: cmw@cmwinc.com

GCAP® ELECTRODE WELD SCHEDULE FOR GALVANIZED STEEL

Metal Thickness	.020	.030	.035	.040	.050	.060	.078	.093	.125
G-CAP	244	254	254	254	255	255	266	266	266
Pressure	300	400	500	650	750	800	1000	1200	1400
Squeeze cycle	25	25	25	25	30	30	30	35	35
Up-Slope cycle					4	4	4	4	5
Upslope Kiloamps					2.0 to S.C.*	2.0 to S.C.*	2.0 to S.C.*	2.0 to S.C.*	2.0 to S.C.*
Weld cycle	6	8	9	10	7	8	10	12	10
Kiloamps	8.5	9.0	9.5	10.0	10.5	11.0	11.5	12.5	13.5
Cool cycle					1	1	1	1	1
Weld cycle					7	8	10	12	10
Kiloamps					10.5	11.0	11.5	12.5	13.5
Cool cycle									1
Weld cycle									10
Kiloamps									13.5
Hold cycle	3	4	4	5	5	10	10	15	20

* S.C. – Starting Weld Current

GCAP® LINEAR STEPPER

Total Weld Count	500	1,000	3,000	5,000	7,500	10,000	12,000
Total Amps Boost	600	1000	3000	5000	6800	8400	9200
Amps Boost Per Weld	1.20	.88		.60			

The above schedules and stepper is only meant to be a guide and will require adjustments to fit the application.

For Additional Welding Information Go To www.HowToResistanceWeld.org



RECOMMENDED ELECTRODE MATERIALS

The process of resistance welding makes it possible to join most metals, similar or dissimilar. Bonds of adequate strength are obtainable for an extremely wide range of applications.

The weldability of two materials as expressed in the following chart has been derived after careful laboratory study and field survey of many factors which influence the welding or resultant weld of the metals. The factors include:

- 1. Thermal and electrical conductivity

- 2. Metallurgical properties
3. Nature of resultant weld or alloy
4. Weld strength
5. Relative accuracy in control of welding conditions necessary

The weldability of metals as shown in the chart applies only when conventional spot welding methods are used on similar thicknesses of material. However, many metal combinations which are listed as having a "poor weldability" may be satisfactorily joined by using a special setup or procedure.

There is a CMW® Alloy for each specific welding application. Experienced CMW engineers will provide assistance with special problems.

Electrode Materials For SPOT WELDING Similar and Dissimilar Metals

Large table with columns for various metals (Tungsten, Magnesium, Nickel, Stainless Steel, etc.) and rows for various electrode materials (Commercially Pure Titanium, Aluminum, Copper, etc.).

WELDABILITY
As a basis for comparison cold rolled (mild) steel has been chosen and its weldability designated as "excellent."

ELECTRODES
I - RWMA CLASS 1
II - RWMA CLASS 2
III - RWMA CLASS 3
IV - RWMA CLASS 11 - 10W
V - RWMA CLASS 14 - 100M*

ELECTRODES
I - RWMA CLASS 1
II - RWMA CLASS 2
III - RWMA CLASS 3
IV - RWMA CLASS 11 - 10W
V - RWMA CLASS 14 - 100M*

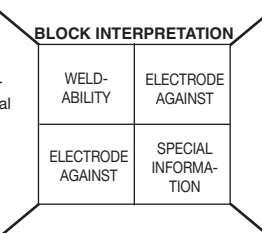

*100W may be substituted.
Δ RWMA CLASS 11 may be interchangeable.
○ Electrode materials in circles are second choice.

- SPECIAL INFORMATION
1. Good weld strength.
2. May be welded under special conditions.
3. Low weld strength.
4. No actual weld nugget occurs, a "stick" is obtained.

For Additional Welding Information
Go To www.HowToResistanceWeld.org



RESISTANCE WELDING ELECTRODE MAINTENANCE

Phone: 800-521-3722

Fax: 864-877-2212

Email: cmw@cmwinc.com

This Chart shows graphically the importance of Electrode maintenance. This is not only important from the quality of the weld, which is of first importance, also extra load added to the welding machine and equipment. Read the data on the chart, you can then draw your own conclusions.

YOU CAN'T AFFORD TO NEGLECT YOUR ELECTRODES!

Keep your Electrodes dressed for maximum production and quality welds.

A TIP DRESSER WILL PAY DIVIDENDS!

We can supply you with hand operated Tip Dressers or Pneumatic Power Driven Dressers. Design or type will depend on your production requirements. Pages 66 & 67.

RESISTANCE WELDING

400% Too Small (A)	Proper New Tips (B)	56% Too Large (C)	125% Too Large (D)	300% Too Large (E)	525% Too Large (F)	800% Too Large (G)
Approx. .012 sq. in. at 1/8" Dia.	Approx. .049 sq. in. at 1/4" Dia.	Approx. .077 sq. in. at 5/16" Dia.	Approx. .110 sq. in. at 3/8" Dia.	Approx. .197 sq. in. at 1/2" Dia.	Approx. .307 sq. in. at 5/8" Dia.	Approx. .442 sq. in. at 3/4" Dia.
2,460 amperes only would be required (†)	9,823 amperes would be required (†)	15,337 amperes would be required (†)	22,100 amperes would be required (†)	39,300 amperes would be required (†)	61,350 amperes would be required (†)	88,500 amperes would be required (†)
127,640 lbs. sq. in. pressure (*)	31,960 lbs. sq. in. pressure (*)	20,470 lbs. sq. in. pressure (*)	14,200 lbs. sq. in. pressure (*)	7,990 lbs. sq. in. pressure (*)	5,120 lbs. sq. in. pressure (*)	3,500 lbs. sq. in. pressure (*)
RESULT: Four times too much pressure, current. Very severe indentation and spitting from high current density.	RESULT: Correct pressure, current, tips. Excellent weld. This is the size tip (new) for which the pressure, time, and current are adjusted.	RESULT: Only 60% of proper pressure, current. Borderline weld. Lower strength. Last diameter size tolerated unless current and pressure were set between the 1/4 and 5/16 size tips.	RESULT: Only 45% of the required pressure and current. Welds would be unacceptable. If the current or time were increased with tips in this condition a large weak weld would result.	RESULT: Only 25% of required current and pressure. No weld would be made if tips were left in this condition.	RESULT: Only 16% of required current and pressure. This is a very serious condition and the only cure is to dress the tips back to (B) condition.	RESULT: Only 11% of needed current and pressure. This is an absurd (though often seen) condition that only heats a spot.
CORRECTION: Cut pressure to 1/4 Cut current to 1/4						

(†) Current density required for this gage to be 200,000 amps per sq. in. Setting is 9,900 amps for condition (B)

(*) Five inch diameter air cylinder A 80 lbs. air pressure—1570 lbs. on ram.

Reproduced by permission of McGraw-Hill Book Company, Inc.

For Additional Welding Information Go To www.HowToResistanceWeld.org

RESISTANCE WELDING DO'S AND DON'TS



Phone: 800-521-3722

Fax: 864-877-2212

Email: cmw@cmwinc.com

DO'S AND DON'TS FOR RESISTANCE WELDING ELECTRODES

DO'S	DON'TS
<ol style="list-style-type: none">1. Use the RWMA recommended electrode material for the job you are running.2. Use RWMA standard electrodes whenever possible.3. Use the appropriate electrode diameter for the material being welded.4. Use open sight drains or have water flow gauges on out bound side to easily confirm water flow.5. Connect the water inlet hose to the proper holder inlet to insure water flows through the center cooling tube first.6. Recommended water flow for the electrodes is 1.5 gallons per minute of cold water.7. Insure that the water tube extends within 0.25" of the bottom of the electrode water hole.8. Adjust the water tube position when changing to another length electrode.9. Check water tube ends to insure they are not damaged and have an angled cut at the end to prevent water restriction.10. Use ejector type holders to simplify electrode removal.11. Keep the electrode and holder tapers clean to ensure good leak free conduction.12. Dress electrodes frequently to insure good quality welds.13. Dress electrodes in a lathe to their original contour whenever possible.14. Use raw-hide or hard rubber hammers for alignment of electrodes.15. Provide cooling water on the exit side top and bottom of seam welding applications.16. Use properly designed knurling wheels to insure continuous dressing of the seam welding wheel.17. Lock out the machine when performing any type of maintenance.	<ol style="list-style-type: none">1. Never use unidentified electrodes or materials.2. Avoid special, offset, or irregular electrodes when the job can be done with standard electrodes.3. Do not use small electrodes on heavy gauge welding jobs or large electrodes on small gauge materials.4. Do not forget to turn the water on full force before starting to weld.5. Never use water hoses that do not fit the water fitting properly.6. Do not allow water connections to become leaky, clogged or broken.7. Avoid holders with leaking or deformed tapers.8. Never use holders that do not have adjustable water deflector tubes.9. Never use pipe tape or similar product to stop a leak.10. Do not let your electrode mushroom excessively.11. Do not dress electrodes with a file.12. Do not use a steel hammer to adjust any part of a welding machine.13. Avoid the use of seam welder wheels too thin to stand the heat or pressure of your job.14. Do not permit seam welding wheels to run off the edge of the work piece.15. Do not enter a work cell or reach into a welder without using your lockout.



WELDING ELECTRODE / CAP EVALUATION FORM

Phone: 800-521-3722

Fax: 864-877-2212

Email: cmw@cmwinc.com

Facility _____

Location _____

Contact _____ Phone _____ Fax _____ Date _____

Equipment --- Plant/Line # _____							
TYPE	Robot	Fixed Auto	Press	Hand	Online	Offline	Other (Specify)
GUN STYLE	C Gun	Pinch	Scissor	Other (Specify)	Comment		
CONDITION	New	Old	Good	Poor			
STEPPER CAPABILITY	Number of Steps	Linear	Non-linear	None			
UP-SLOPE CAPABILITY	Yes	No					
PULSE CAPABILITY	Yes	No					
NUMBER OF	Schedules per SCR	Transformers per SCR	Guns per Transformer	Transformer Taps	Transformer KVA		

Workpieces (Materials)							
POSITION	THICKNESS	CHECK ONE (per workpiece)					
		Bare Steel	Aluminized	Zn Electroplate	Galvanneal	Hot Dipped Galvanized	Organic
Outside							
Inside							
Inside							
Outside							
FIT-UP	Good	Poor	Comments				

ELECTRODES							
NOSE STYLE	A (Pointed)	B (Dome)	C (Flat)	D (Offset)	E (Truncated)	F (Radius)	Other (Specify)
MATERIAL	Class 1	Class 2	Class 20 (DSC)	Other (Specify)			
TAPER STYLE	Female	Male			Comments		
ALIGNMENT	Good	Poor	Requires Backup				

QUOTE REQUEST SPECIALS AND CUSTOMS



Phone: 800-521-3722

Fax: 864-877-2212

Email: cmw@cmwinc.com

Contact Name: _____ Company: _____

Address: _____

Phone: _____ Fax: _____ Email: _____

Part Information: _____ Material/Alloy: _____

Part Number or Description: _____

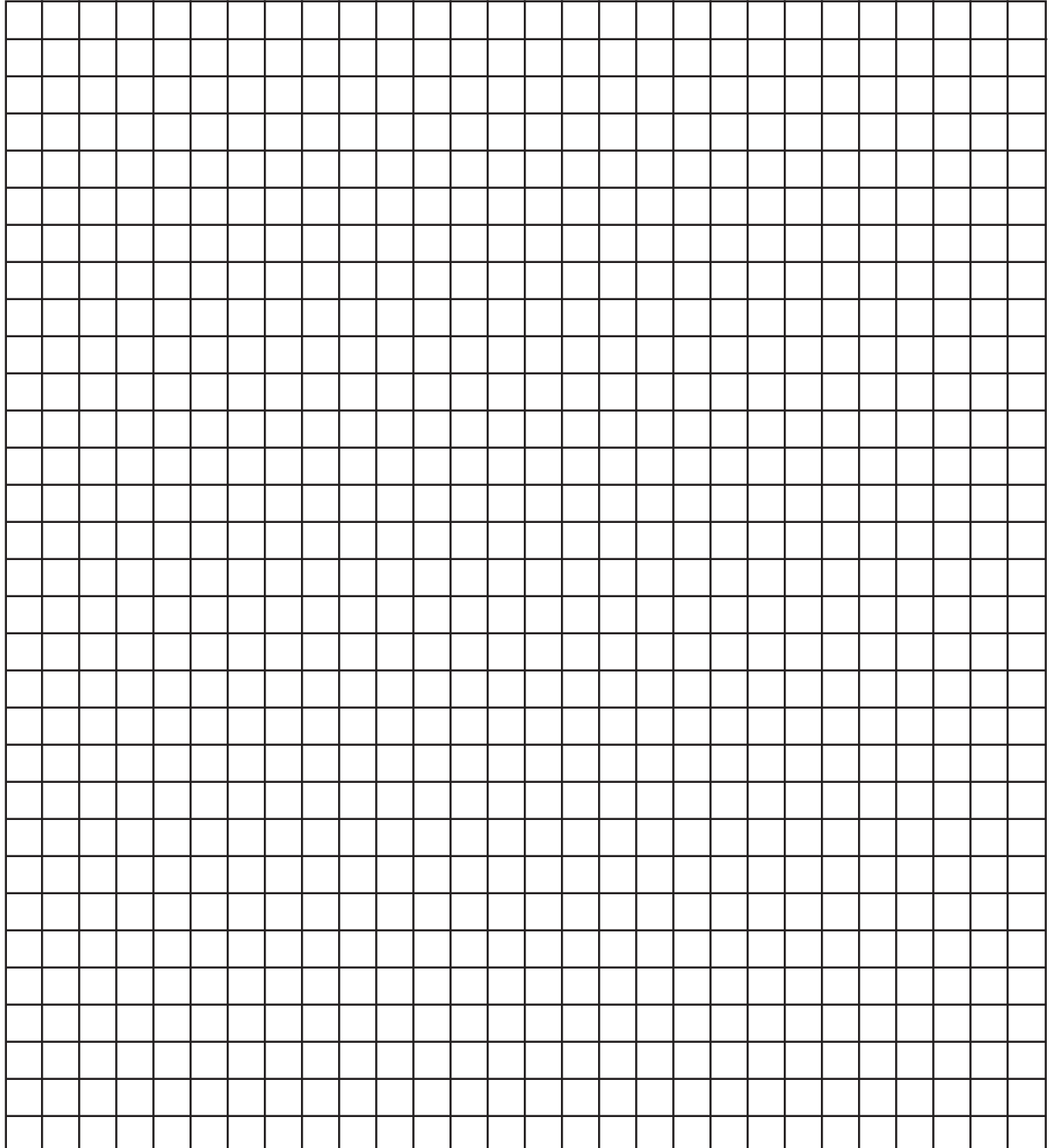

Please send a photo of part laying on the grid area of this completed page to – customerservice@cmwinc.com

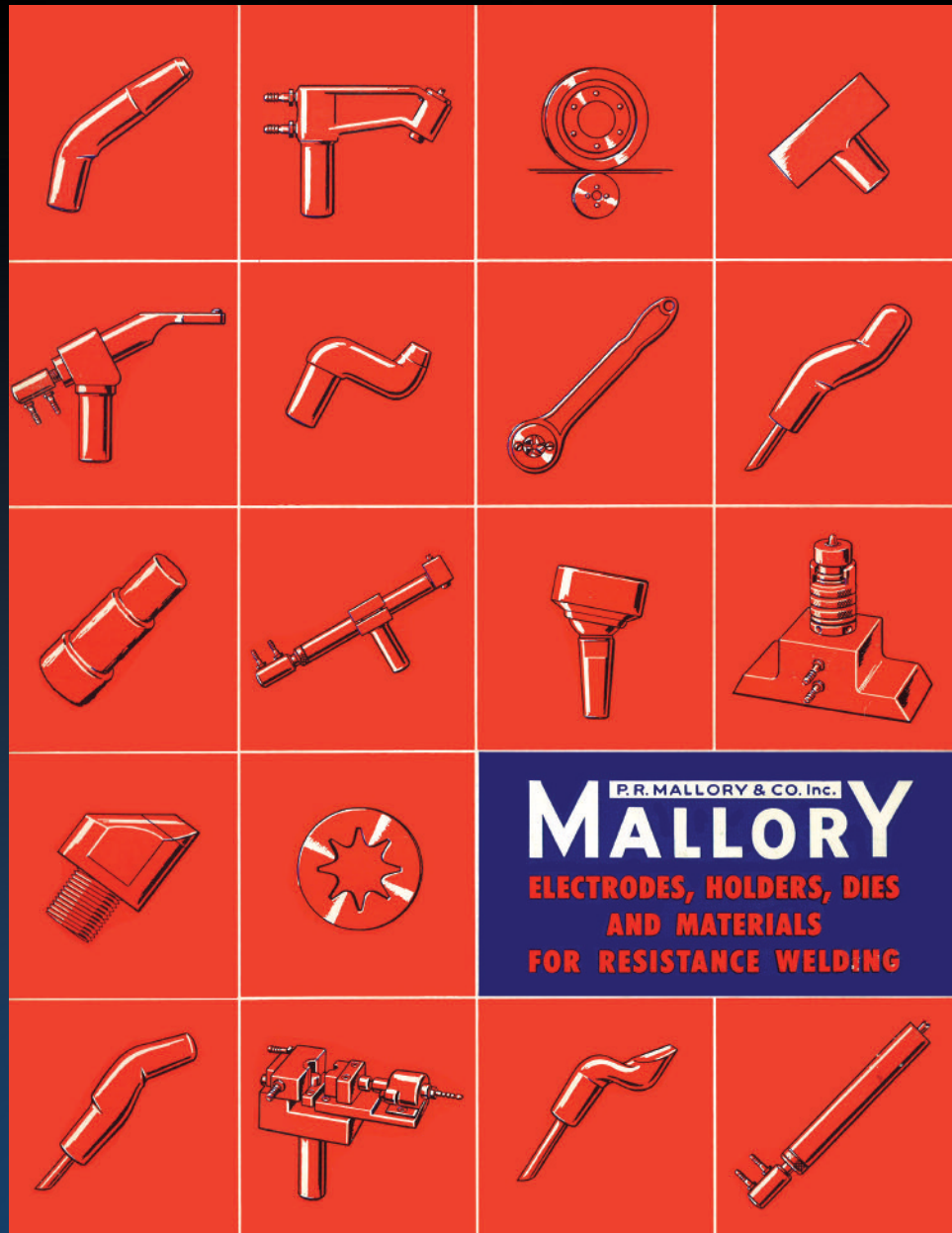

The development of **CMW Resistance Welding Products** traces back to the early Twentieth Century and Phillip Rogers Mallory during the period of the expansion of the use of assembly line mass production techniques in America.

Mallory Metallurgical Company, founded by P. R. Mallory, began to develop and manufacture resistance welding products utilizing the elements copper, silver and tungsten, to provide industry with improved ways to bond metals and create lighter, more cost effective products for consumers. Mallory worked with Henry Ford on the first automotive application for resistance welding.

Mallory established itself as a leading contributor to the Allied war effort during WWII, producing products for a range of applications on the battlefield, in the air and on the ocean. Of particular note,

Mallory developed revolutionary battery technology, perfecting the alkaline dry-cell battery to be known as the Duracell® battery.

In the late 1970s, as part of the larger corporate strategy, Mallory sold select assets of the Mallory Metallurgical Co. to its divisional management team lead by Howard D. Johnston, who formed a new corporation and named it CMW Inc. CMW solidified its reputation for product innovation, quality and service in all its specialty metals business and became further ingrained as the supplier of choice in American Industry for resistance welding products.

Today CMW Resistance Welding Products is a division of Tuffaloy Products, Inc. and continues to serve CMW customers worldwide, exporting to over 40 countries and across a variety of industries.



- Resistance Welding Consumables
- Resistance Welding Hardware
- RWMA Group A & B Materials
- Cold Heading
- Custom Machining

Experience • Technology • Results



RESISTANCE
WELDING PRODUCTS

CMW Resistance Welding Products
1400 S. Batesville Road
Greer, SC 29650

Toll Free Phone: 800-521-3722

Fax: 864-877-2212

Email: cmw@cmwinc.com

Website: www.cmwinc.com

The information contained herein is believed to be correct, but no guarantee or warranty with respect to accuracy, completeness or results is implied and no liability is assumed. Nothing herein is to be construed as advising or authorizing practice of any invention covered by existing patents owned by Tuffaloy Products Inc. or others without license from the owners thereof. The names FIN CAP™, "NU-TWIST"®, GCAP®, MCAP®, and CHAMELEON / MAXLIFE™, are federally registered trademarks owned by Tuffaloy Products Inc. and are used herein to identify respective series of alloys and products which Tuffaloy Products Inc. manufactures and sells. Any unauthorized or improper use of such marks without the express written consent of Tuffaloy Products Inc. is prohibited. In the interest of improved design and performance, Tuffaloy Products Inc. reserved the right to make changes in any specification, data or material contained herein.